

FED. ROAD DIST. NO.	STATE	FED. AID PROJ. NO.	FISCAL YEAR	SHEET NO.	TOTAL SHEETS
HAWAII	HAW.	LEFF-078(6)	1976	52	142

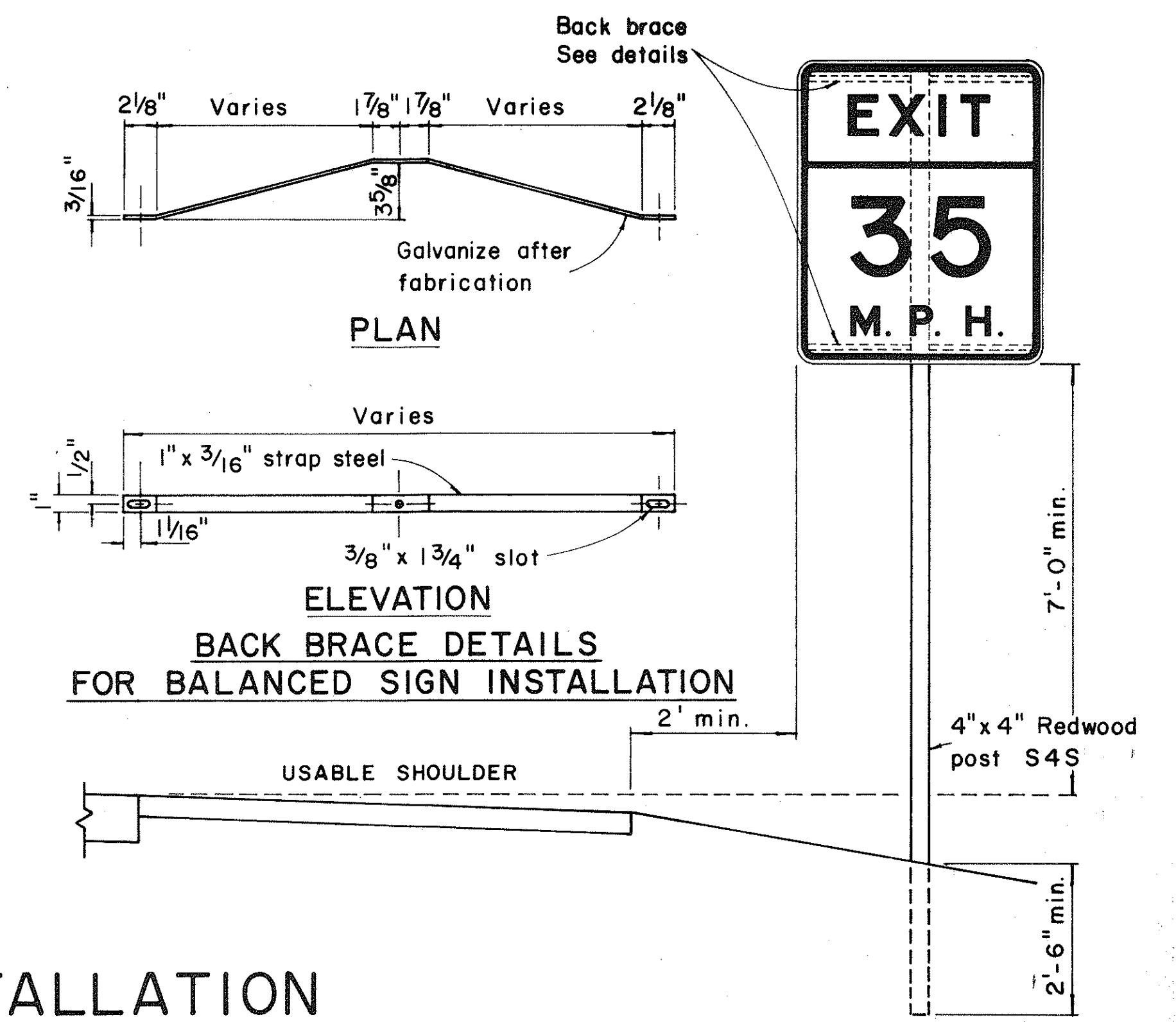

HEIGHT AND LATERAL LOCATION OF SIGNS - TYPICAL INSTALLATION

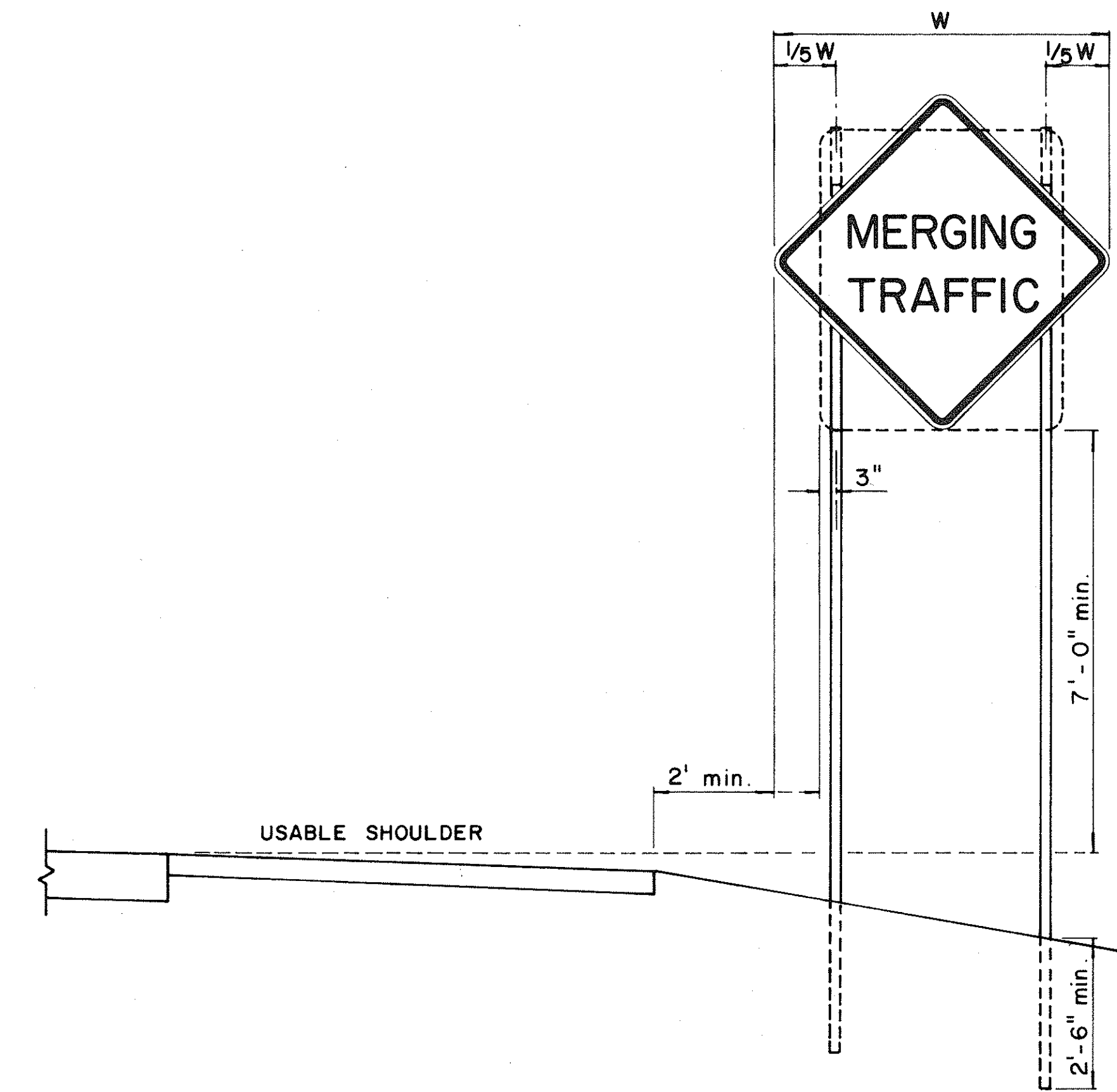
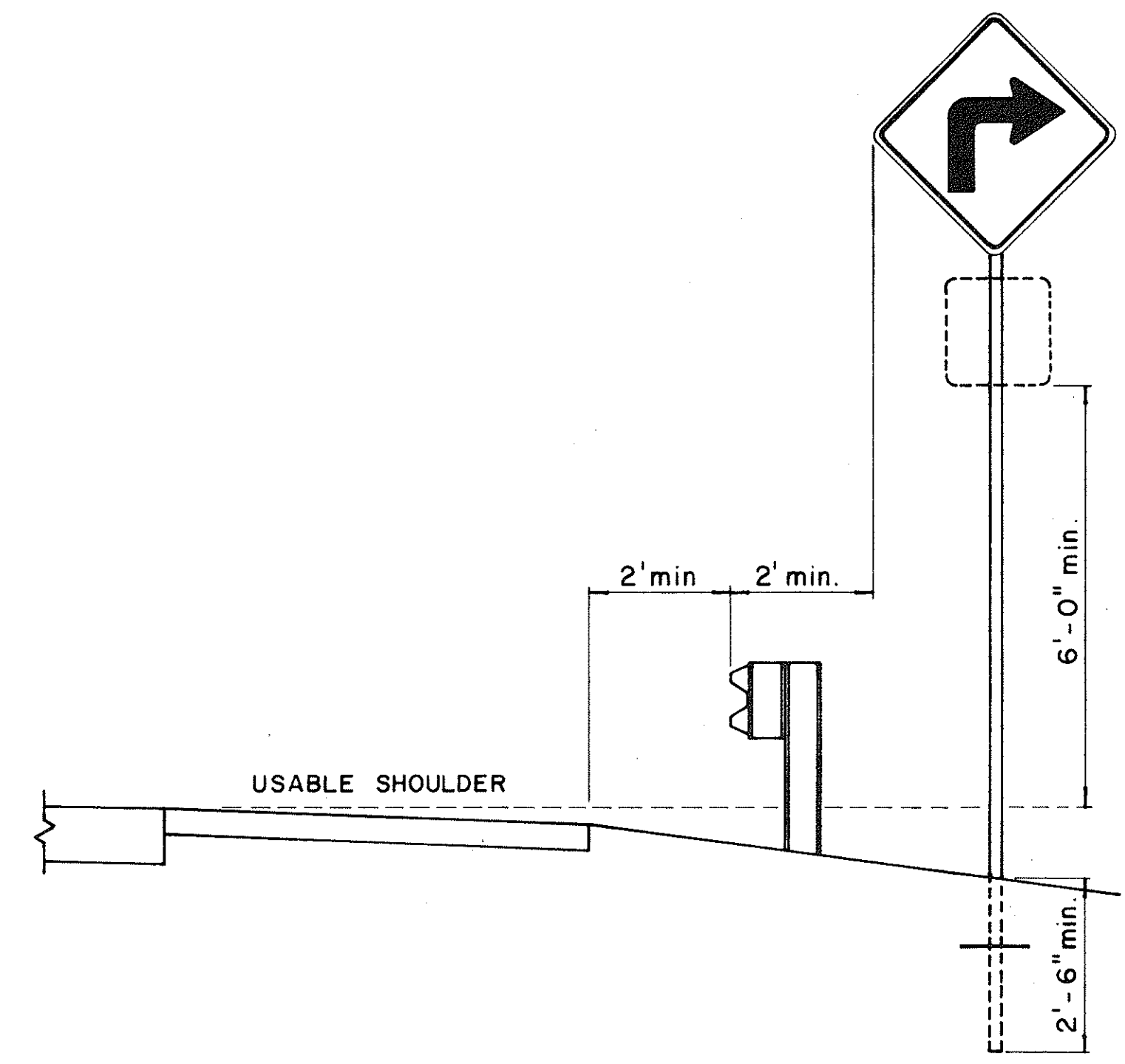
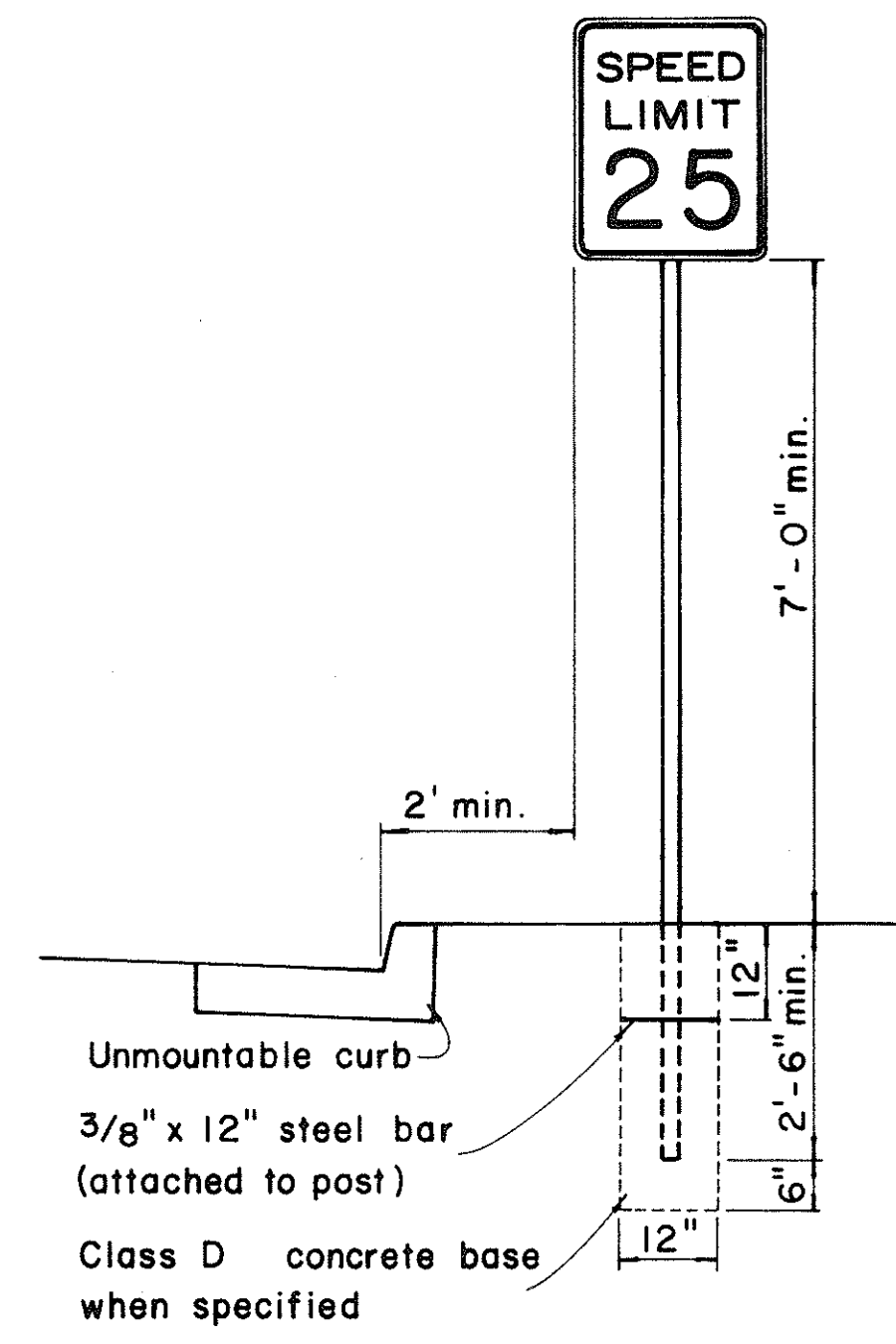
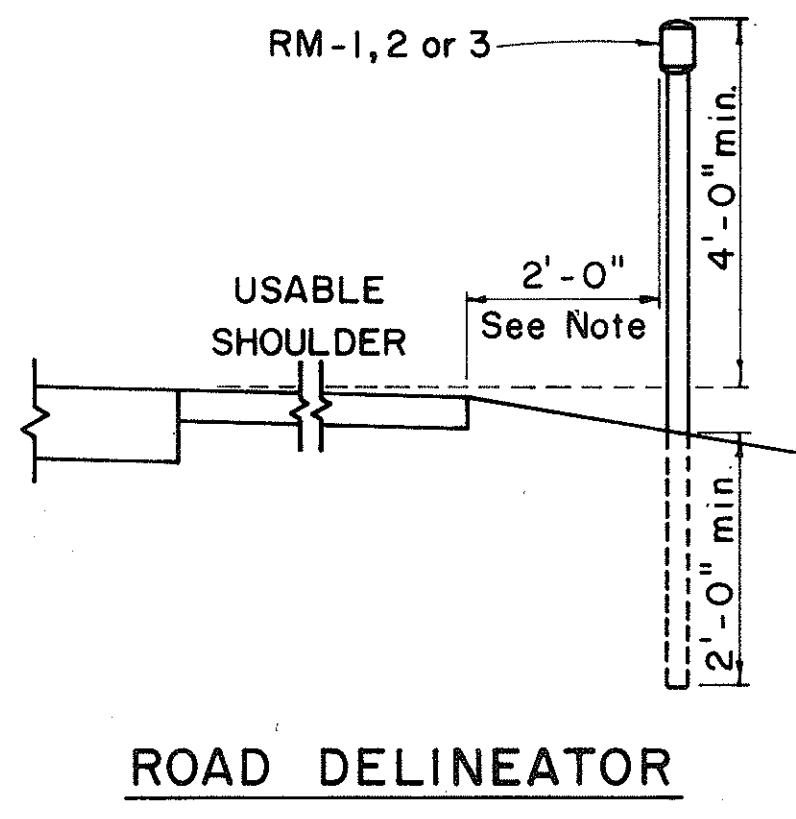

Galv. flanged channel 1/8" x 3 1/16" rolled section post with a minimum weight of 2 lbs. per ft. Upper 2 ft. shall have a single row of 3/8" holes centered in the web at 1" o.c.

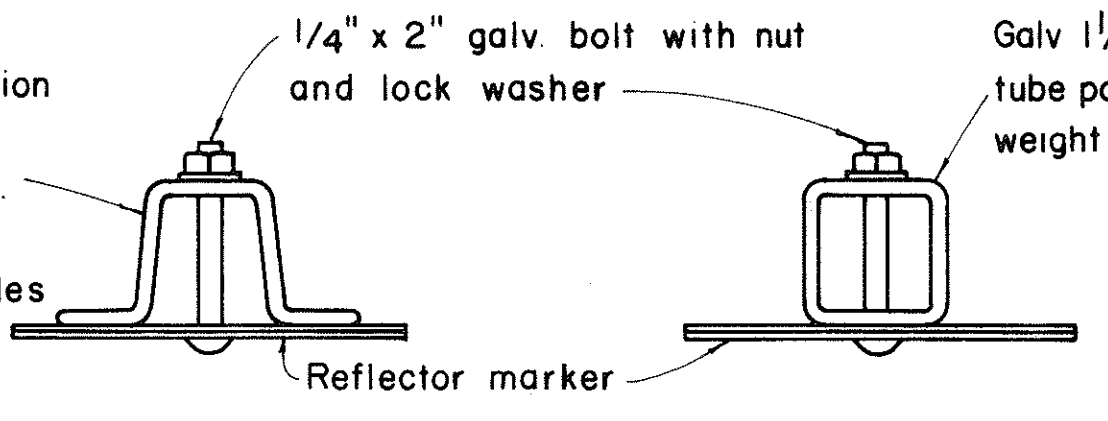

TYPICAL SECTION OF ROAD DELINEATOR

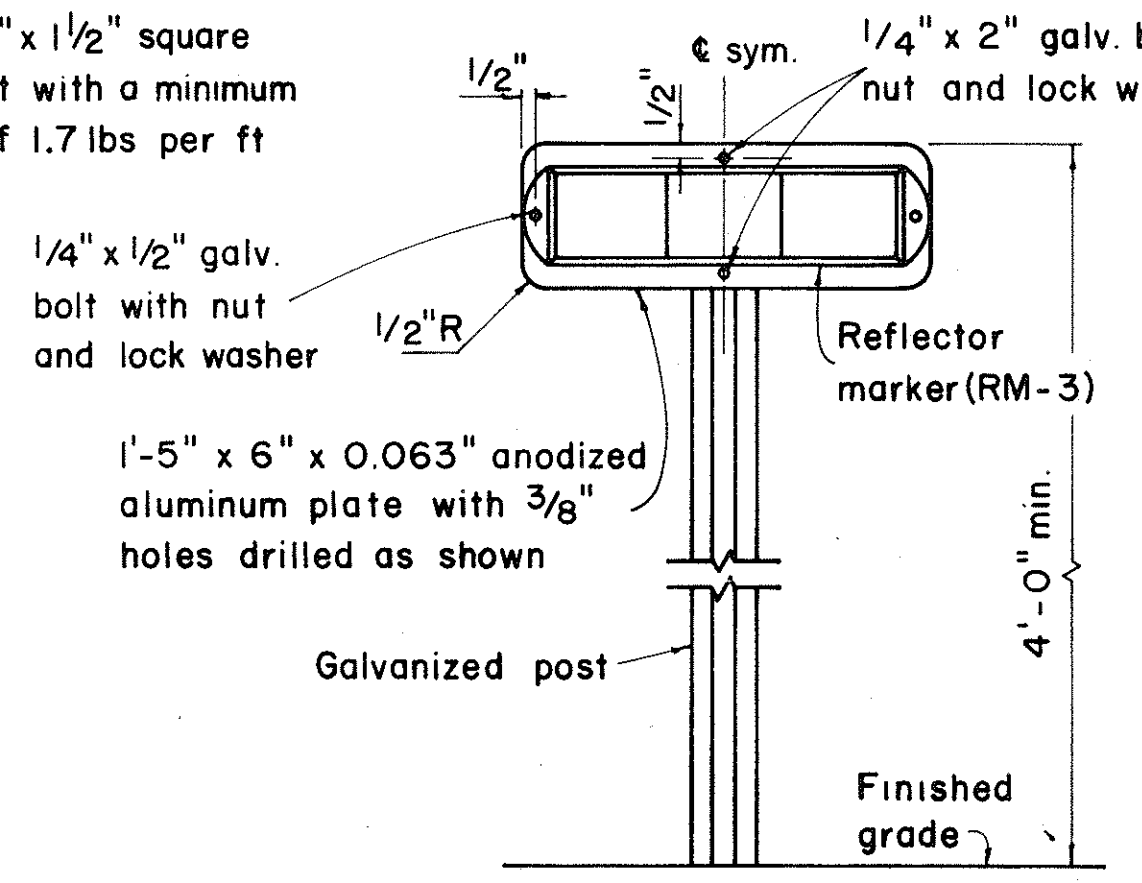

TYPICAL DETAIL
HORIZONTAL REFLECTOR MARKER
RM-3H

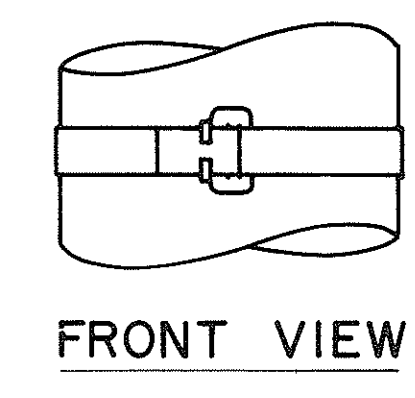
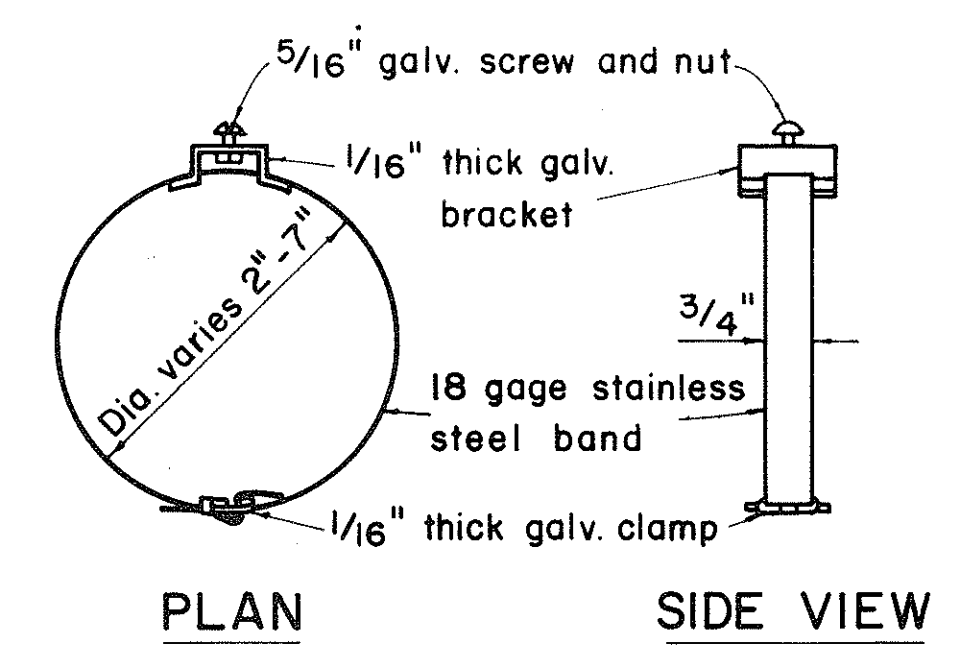

TYPICAL BAND BRACKET FOR
MOUNTING TRAFFIC SIGNS

- GENERAL NOTES:**
- Sign posts shall be 2" galv. standard pipe or 2" x 2" galv. sq. tube post.
 - Signs 48" and wider or larger than 10 sq. ft. in area shall be mounted on two 2" galv. standard pipe or two 2" x 2" galv. sq. tube post or 4" x 4" redwood post S4S.
 - Signs shall be attached to post with 5/16" galv. bolts with nuts and 7/8" x 0.06 stainless steel washers with neoprene rubber gasket.
 - Sign posts shall extend 3 1/2" above sign where required for City and County street name signs.
 - Reflector markers RM-1, 2, 3 shall be glass sphere reflector markers with 4" x 5" reflector units (as shown) or plastic prismatic reflector markers with 3" diameter reflector units.
 - Clearance markers (RM-3, RM-4) shall be installed with the edge of the marker in line with the inner edge of the obstruction.
 - (R) or (L) indicates right or left and shall be as shown on the plans.

APPROVAL RECOMMENDED:
Eishi Tanaka 12/29/69
TRAFFIC ENGINEER DATE

APPROVED:
[Signature] 12-30-69
ASSISTANT CHIEF, ENGINEERING DATE

NO.	REVISION	APPROVED BY	DATE

STATE OF HAWAII
DEPARTMENT OF TRANSPORTATION
HIGHWAYS DIVISION

STANDARD DETAILS
MISCELLANEOUS SIGN DETAILS

Not to scale March, 1968

SHEET No. 1 OF 13 SHEETS DT 100

SURVEYED BY: _____ DATE: _____
 DRAWN BY: _____
 DESIGNED BY: _____
 NOTE BOOK: _____
 CHECKED BY: _____
 No. _____

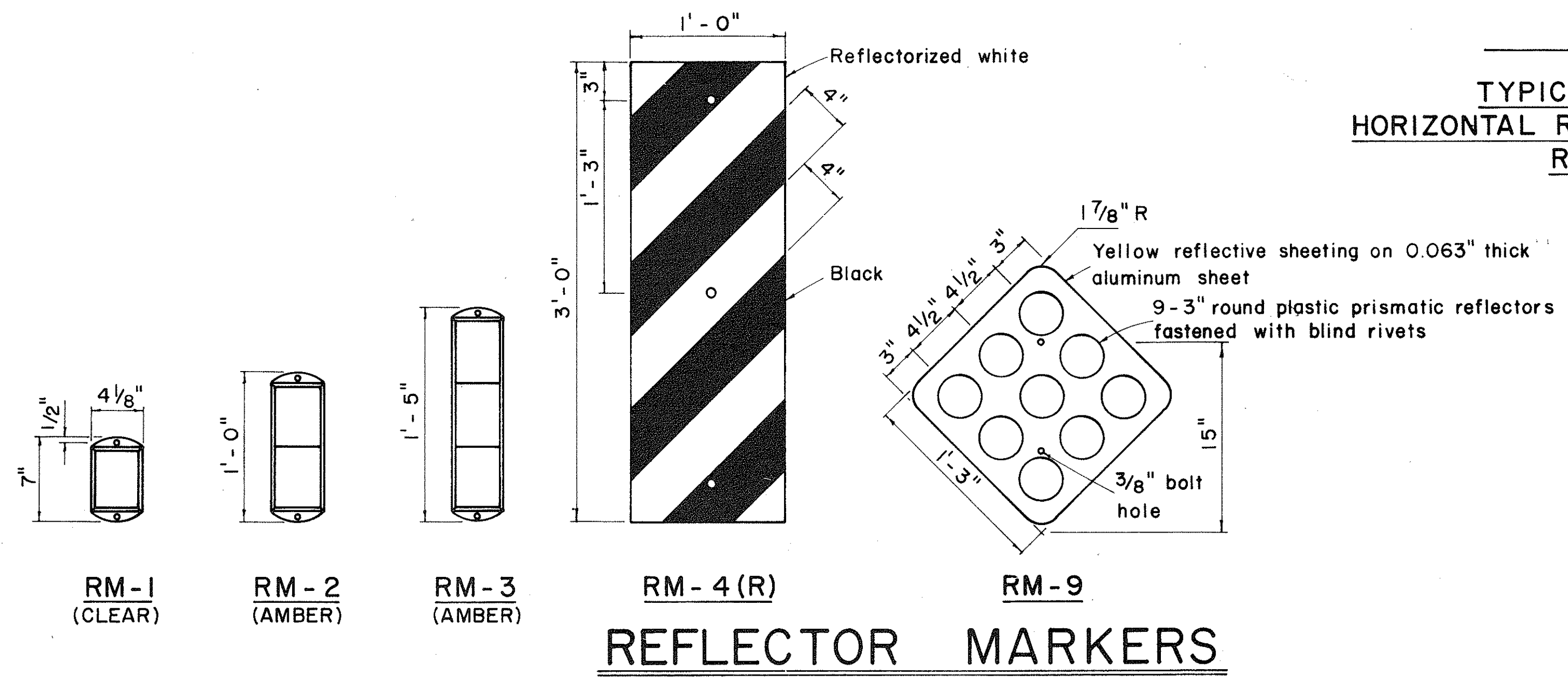

REFLECTOR MARKERS

FED. ROAD DIST. NO.	STATE	FED. AID PROJ. NO.	FISCAL YEAR	SHEET NO.	TOTAL SHEETS
HAWAII	HAW.	U-FE-078-1(6)	1976	53	142



RI-1 30" x 30"
RI-1-A 36" x 36"
4-WAY
RI-3 12" x 6"
RI-3-A 18" x 9"

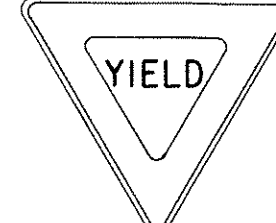

RI-2 36" x 36" x 36"
RI-2-A 48" x 48" x 48"



R2-1(50) 24" x 30"
R2-1(50)-A 48" x 60"

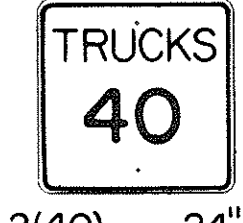

R2-2(40) 24" x 24"
R2-2(40)-A 48" x 48"

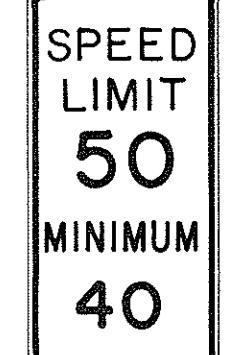

R2-4a(50/40) 24" x 48"
R2-4a(50/40)-A 48" x 96"

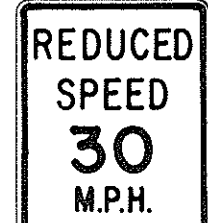

R2-5b(30) 24" x 30"
R2-5b(30)-A 48" x 60"

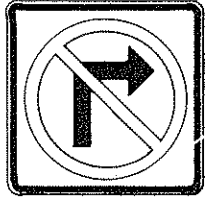

R3-1 24" x 24"
24" x 18"
R3-1-A 48" x 48"
48" x 36"

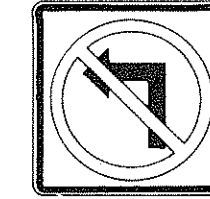

R3-2 24" x 24"
24" x 18"
R3-2-A 48" x 48"
48" x 36"



R3-3 24" x 24"
R3-3-A 48" x 48"

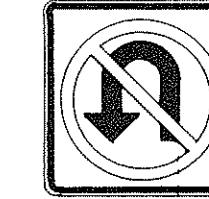

R3-4 24" x 24"
24" x 18"
R3-4-A 48" x 48"
48" x 36"

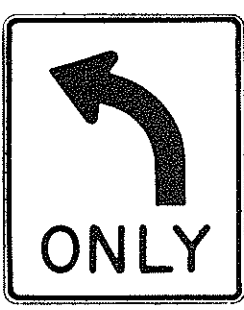

R3-5(L) 30" x 36"
R3-5(L)-A 48" x 60"

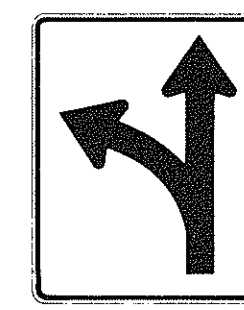

R3-6(L) 30" x 36"
R3-6(L)-A 48" x 60"



R3-7(R) 30" x 30"
R3-7(R)-A 48" x 48"



R3-8(L) 30" x 30"
R3-8(L)-A 36" x 36"
R3-8(L)-B 48" x 48"

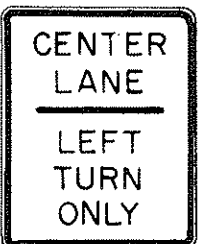

R3-9 24" x 30"



R4-1 24" x 30"



R4-2 24" x 30"



R4-3 24" x 30"
R4-3-A 48" x 60"

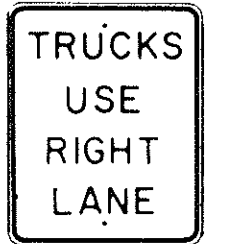

R4-5 24" x 30"

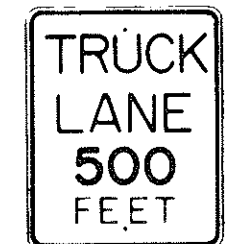

R4-6(500) 24" x 30"

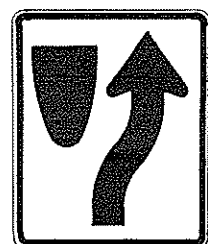

R4-7 24" x 30"
24" x 18"

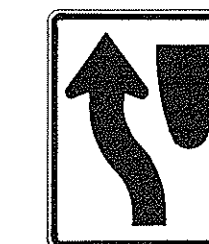

R4-8 24" x 30"
24" x 18"

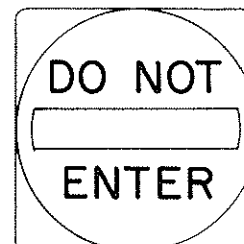

R5-1 30" x 30"
R5-1-A 48" x 48"

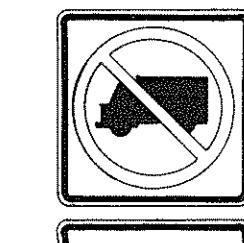

R5-2 24" x 24"
24" x 18"

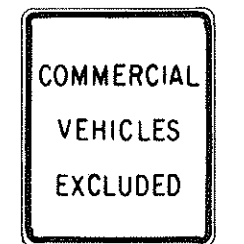

R5-4 24" x 30"

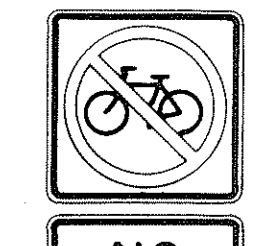

R5-6 24" x 24"
24" x 18"



R5-9 36" x 24"



R6-1(R) 36" x 12"



R6-2(R) 18" x 24"



R7-1 12" x 18"
R7-1-A 24" x 30"

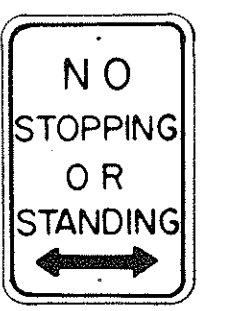

R7-4 12" x 18"
R7-4-A 24" x 30"



R7-107(R) 12" x 18"

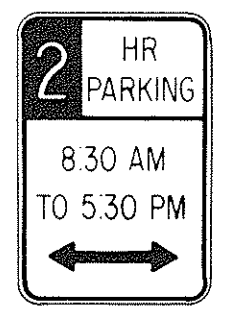

R7-108 12" x 18"



R7-201 12" x 6"
R7-201-A 24" x 12"



R8-1 24" x 30"



R8-2 24" x 30"



R8-3 24" x 30"



R8-4 30" x 24"
R8-4-A 48" x 36"



R8-5 24" x 30"



R8-6 24" x 30"

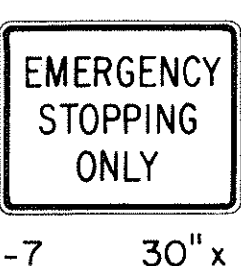

R8-7 30" x 24"
R8-7-A 48" x 36"

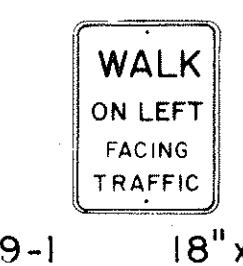

R9-1 18" x 24"

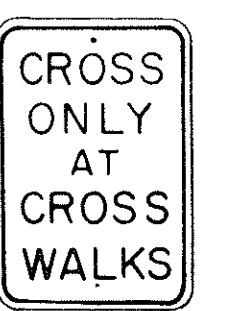

R9-2 12" x 18"



R9-3 12" x 18"



R9-4 18" x 24"

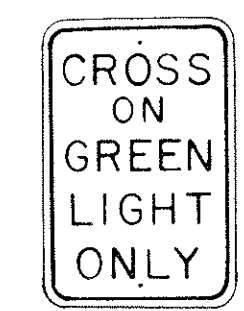

R10-1 12" x 18"

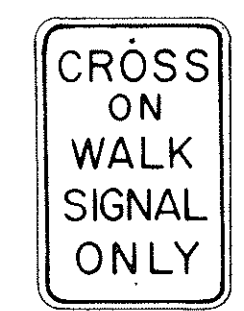

R10-2 12" x 18"

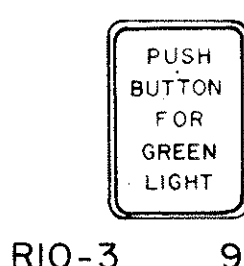

R10-3 9" x 12"

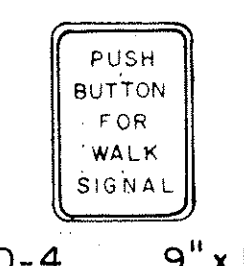

R10-4 9" x 12"

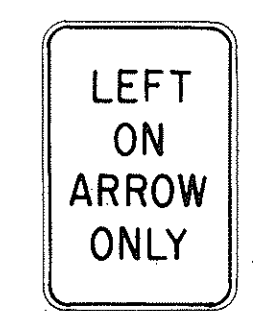

R10-5 24" x 30"

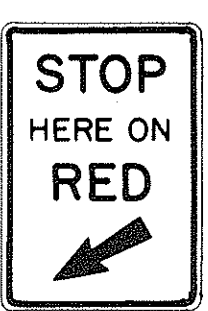

R10-6 24" x 36"

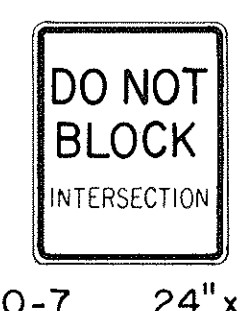

R10-7 24" x 30"

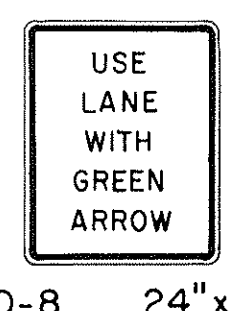

R10-8 24" x 30"

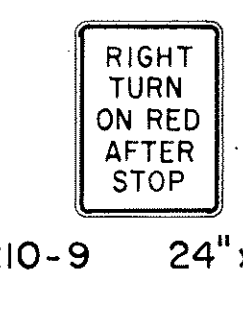

R10-9 24" x 30"

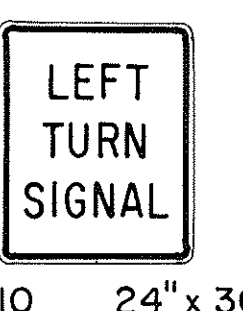

R10-10 24" x 30"

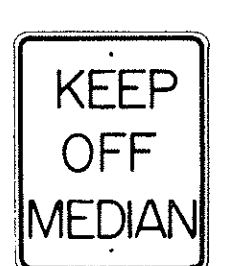

RI1-1 24" x 30"



RI1-2 48" x 30"

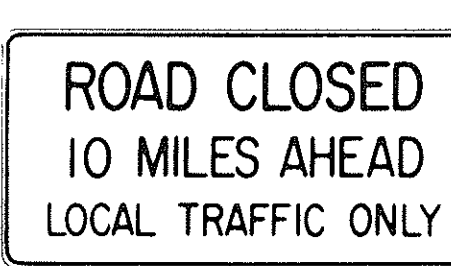

RI1-3(10) 60" x 30"

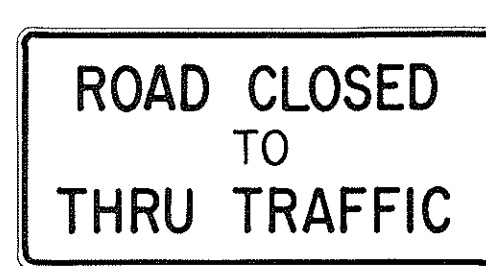

RI1-4 60" x 30"

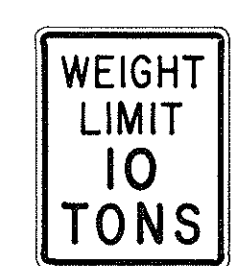

RI2-1(10) 24" x 30"

GENERAL NOTES

- Sign details shall conform to the FHWA publications "Manual on Uniform Traffic Control Devices for Streets and Highways," 1971, and "Standard Highway Signs," 1972, and as amended.
- All regulatory signs shall be reflectorized unless otherwise specified.
- All regulatory signs shall have 3/8" bolt holes drilled at appropriate locations.
- Numerals in () indicates numerals to be inserted for sign message. (R) or (L) indicates right or left.

APPROVAL RECOMMENDED:
Eishi Tanaka 3/17/72
TRAFFIC ENGINEER DATE

APPROVED:
Julius J. Zolner 3-20-72
ASSISTANT CHIEF, ENGINEERING DATE

NO.	REVISION	APPROVED BY	DATE
1	Supersedes Sht. DT 101 Approved 12-30-69	H.I.	3/20/72
2	Revised General Note 1.	H.I.	10/14/74





STATE OF HAWAII
DEPARTMENT OF TRANSPORTATION
HIGHWAYS DIVISION





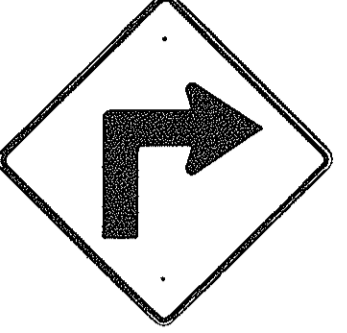
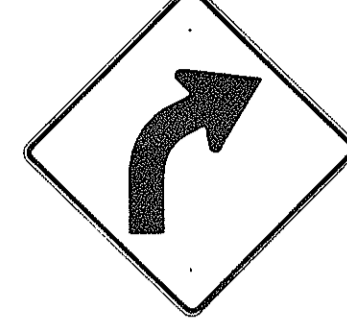
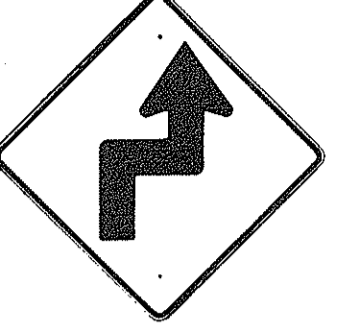

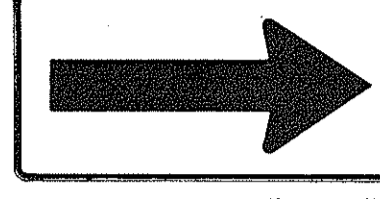
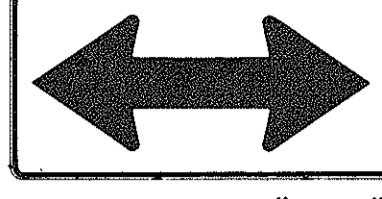

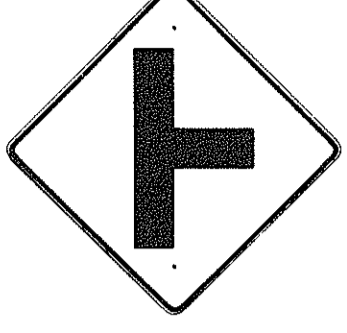
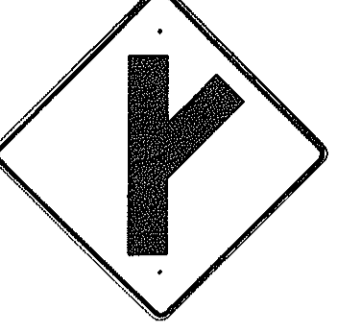
STANDARD DETAILS
REGULATORY SIGNS

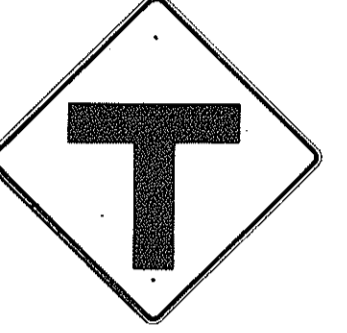
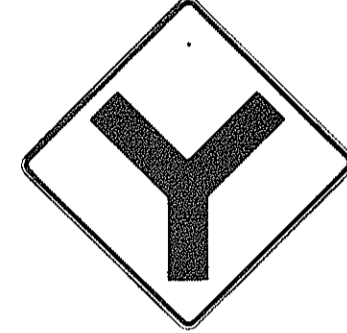

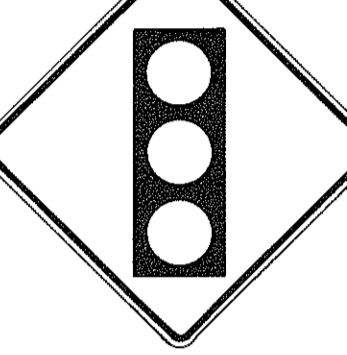

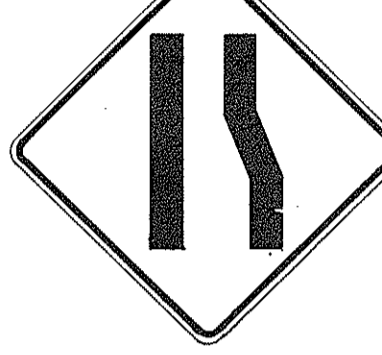





NOT TO SCALE
SHEET No. 2 OF 13 SHEETS DT 101

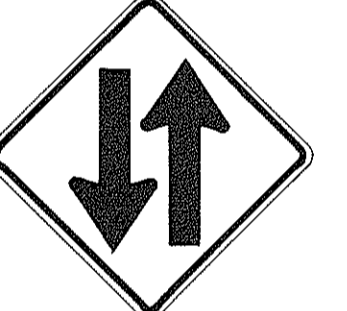





DATE: _____
SURVEY PLOTTED BY: _____
DRAWN BY: _____
DESIGNED BY: _____
CHECKED BY: _____
NOTE BOOK No. _____





FED. ROAD DIST. NO.	STATE	FED. AID PROJ. NO.	FISCAL YEAR	SHEET NO.	TOTAL SHEETS
HAWAII *	HAW.	11-F-078(6)	1976	54	142

									
W1-1(R) 30"x30" W1-1(R)-A 48"x48"	W1-2(R) 30"x30" W1-2(R)-A 48"x48"	W1-3(R) 30"x30" W1-3(R)-A 48"x48"	W1-4(R) 30"x30" W1-4(R)-A 48"x48"	W1-5(R) 30"x30" W1-5(R)-A 48"x48"	W1-6 48"x24"	W1-7 48"x24"	W2-1 30"x30" W2-1-A 48"x48"	W2-2 30"x30" W2-2-A 48"x48"	W2-3(R) 30"x30" W2-3(R)-A 48"x48"

									
W2-4 30"x30" W2-4-A 48"x48"	W2-5 30"x30" W2-5-A 48"x48"	W3-1 30"x30" W3-1-A 36"x36"	W3-2 30"x30" W3-2-A 36"x36"	SIGNAL AHEAD W3-3 36"x36" 24"x18"	MERGE W4-1(R) 30"x30" 24"x18" W4-1(R)-A 48"x48" 24"x18"	W4-2(R) 36"x36" W4-2(R)-A 48"x48"	W5-1 36"x36"	W5-2 30"x30" W5-2-A 36"x36"	W5-3 36"x36"

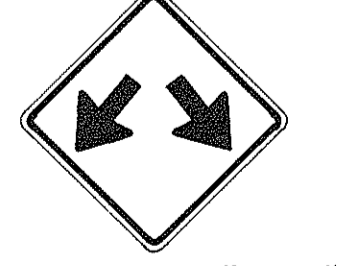
									
DIVIDED HIGHWAY W6-1 36"x36" 24"x18"	DIVIDED HIGHWAY ENDS W6-2 36"x36" 24"x18"	TWO WAY TRAFFIC W6-3 30"x30" 24"x18" W6-3-A 36"x36" 24"x18" W6-3-B 48"x48" 24"x18"	HILL W7-1 30"x30" 24"x18" W7-1-A 36"x36" 24"x18"	USE LOW GEAR W7-2 24"x18"	BUMP W8-1 30"x30" W8-1-A 36"x36"	DIP W8-2 30"x30" W8-2-A 36"x36"	PAVEMENT ENDS W8-3 30"x30" W8-3-A 36"x36"	SOFT SHOULDER W8-4 30"x30" W8-4-A 36"x36"	SLIPPERY WHEN WET W8-5 30"x30" 24"x18" W8-5-A 36"x36" 24"x18"

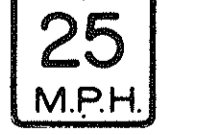
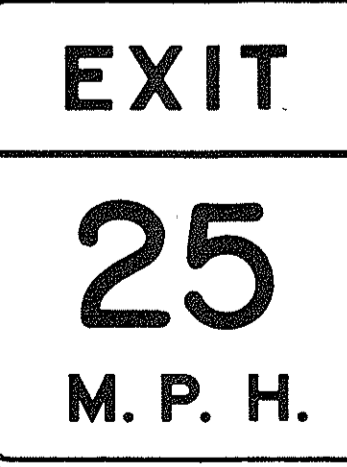
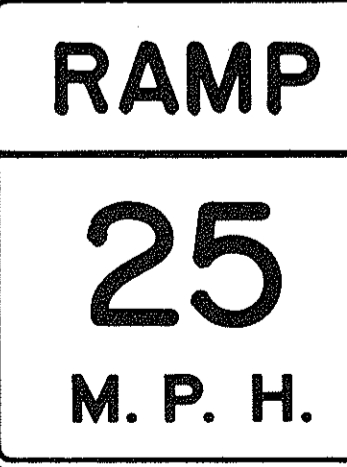
						
RIGHT LANE ENDS W9-1(R) 30"x30" W9-1(R)-A 36"x36" W9-1(R)-B 48"x48"	LANE ENDS MERGE LEFT W9-2(L) 36"x36" W9-2(L)-A 48"x48"	W10-1 36" Diameter	BIKE XING W11-1 30"x30" 24"x18" W11-1-A 36"x36" 24"x18"	PED XING W11-2 30"x30" 24"x18" W11-2-A 36"x36" 24"x18"	CATTLE XING W11-4 30"x30" 24"x18" W11-4-A 36"x36" 24"x18"	FARM MACHINERY W11-5 30"x30" 24"x18" W11-5-A 36"x36" 24"x18"

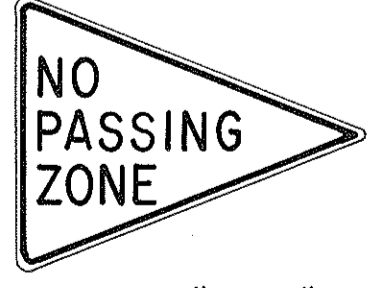
						
W12-1 24"x24" W12-1-A 36"x36" W12-1-B 48"x48"	LOW CLEARANCE W12-2(12'-6") 36"x36" 24"x18"	25 M.P.H. W13-1(25) 18"x18" W13-1(25)-A 24"x24"	EXIT 25 M.P.H. W13-2(25) 48"x60"	RAMP 25 M.P.H. W13-3(25) 48"x60"	DEAD END W14-1 30"x30"	NO PASSING ZONE W14-3 36"x48"x48"

GENERAL NOTES

1. Sign details shall conform to the FHWA publications "Manual on Uniform Traffic Control Devices for Streets and Highways," 1971, and "Standard Highway Signs," 1972, and as amended.
2. All warning signs shall be reflectorized unless otherwise specified.
3. All warning signs shall have 3/8" bolt holes drilled at appropriate locations.
4. Numerals in () indicates numerals to be inserted for sign message. (R) or (L) indicates right or left.
5. Signs prefixed with "CW" on the plans shall indicate orange and black construction signs, reflectorized with high intensity reflective sheeting.

APPROVAL RECOMMENDED:
Erich Tanaka 3/17/72
TRAFFIC ENGINEER DATE

APPROVED:
Walter Salsido 3-20-72
ASSISTANT CHIEF, ENGINEERING DATE

NO.	REVISION	APPROVED BY	DATE
1	Supersedes Sht. DT 102 Approved 12-30-69	H.T.	3/20/72
2	Revised General Note 1	H.T.	10/16/74
3	Revised General Note 5	M.F.	9-16-75

STATE OF HAWAII
DEPARTMENT OF TRANSPORTATION
HIGHWAYS DIVISION

STANDARD DETAILS
WARNING SIGNS

NOT TO SCALE

DATE _____
SURVEY PLOTTED BY _____
DRAWN BY _____
CHECKED BY _____
NOTE BOOK _____
No. _____

FED. ROAD DIST. NO.	STATE	FED. AID PROJ. NO.	FISCAL YEAR	SHEET NO.	TOTAL SHEETS
HAWAII	HAW.	U.F.F. 078-1(6)	1976	55	142

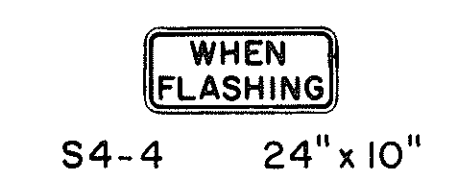
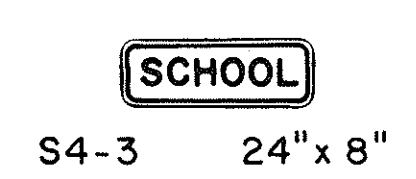
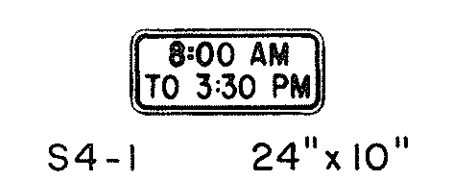
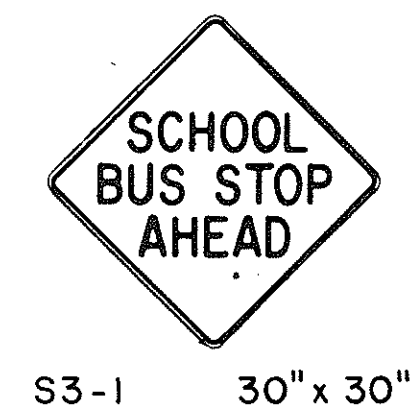
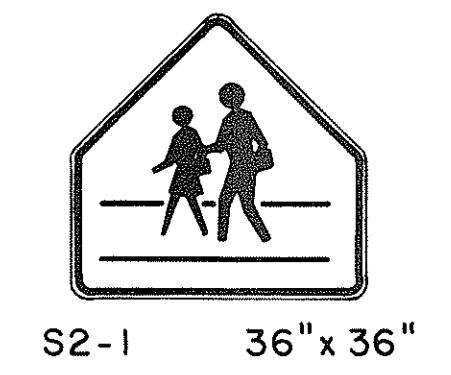
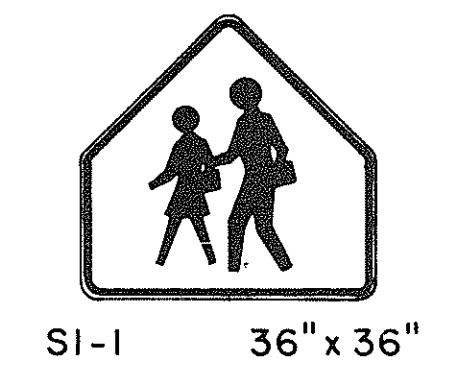
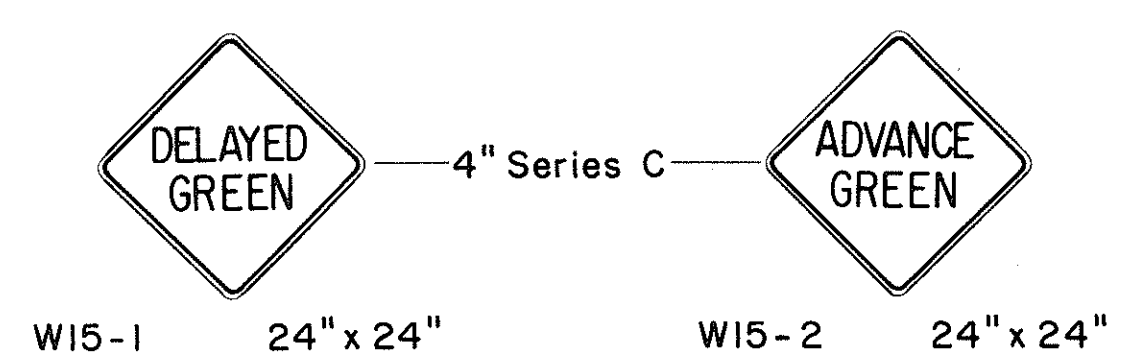
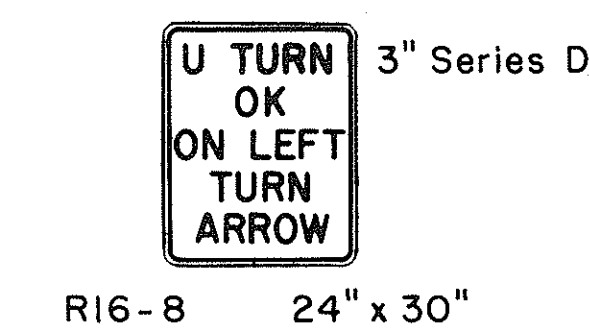
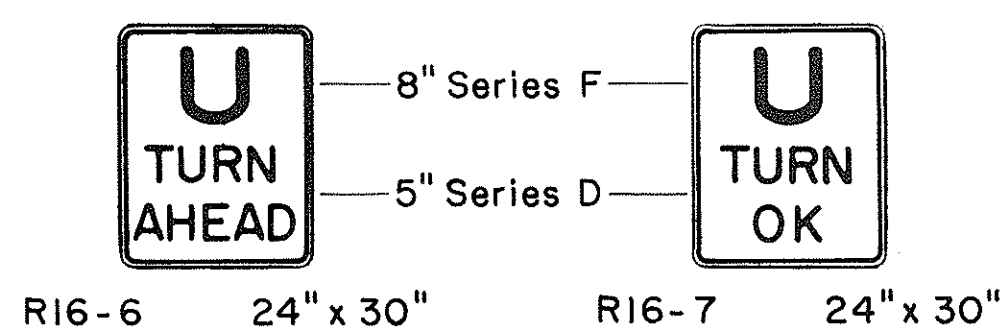
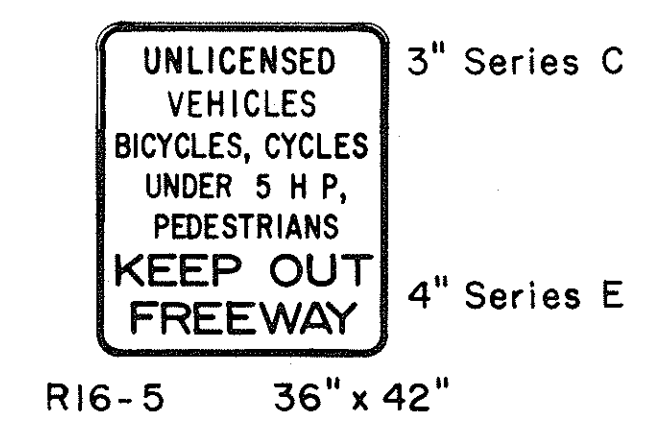
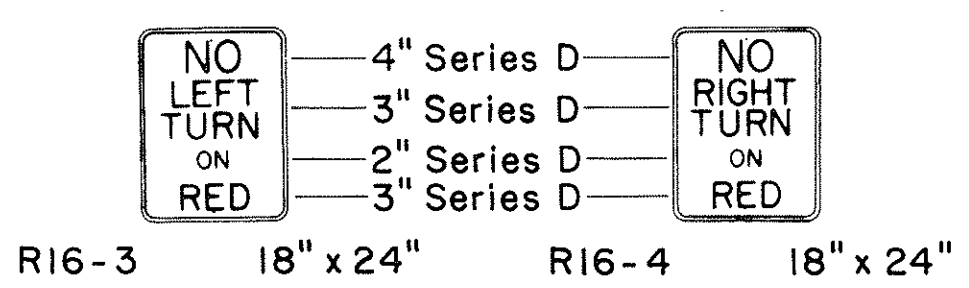
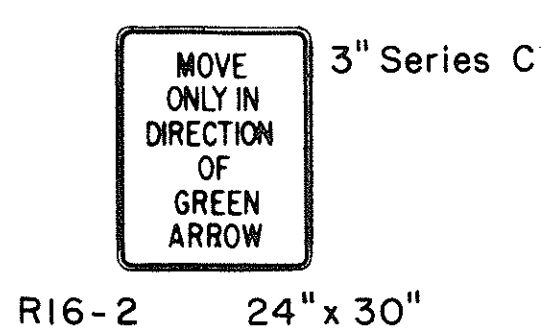
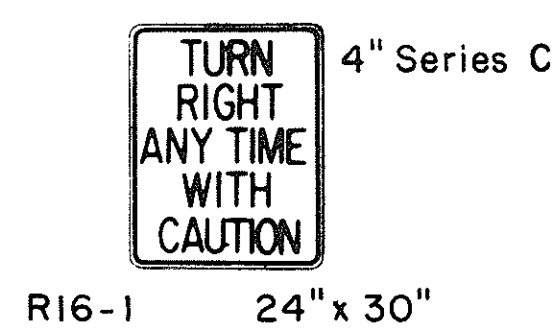

GENERAL NOTES

1. Sign details shall conform to the FHWA publications "Manual on Uniform Traffic Control Devices for Streets and Highways," 1971, and "Standard Highway Signs," 1972, and as amended.
2. All regulatory and warning signs shall be reflectorized unless otherwise specified.
3. All regulatory and warning signs shall have 3/8" bolt holes drilled at appropriate locations.
4. Numerals in () indicates numerals to be inserted for sign message. (R) or (L) indicates right or left.

APPROVAL RECOMMENDED:
Eishi Tanaka
 TRAFFIC ENGINEER
 DATE: 3/17/72

APPROVED:
Robert Zatsich
 ASSISTANT CHIEF, ENGINEERING
 DATE: 3-20-72

NO.	REVISION	APPROVED BY	DATE
1	Supersedes Sht. DT 103 Approved 12-30-69	H.T.	3/20/72
2	Revised General Note 1	H.T.	10/16/74

STATE OF HAWAII
 DEPARTMENT OF TRANSPORTATION
 HIGHWAYS DIVISION

STANDARD DETAILS
MISCELLANEOUS
REGULATORY & WARNING SIGNS

NOT TO SCALE
 SHEET No. 4 OF 13 SHEETS DT 103

DESIGNED BY	DATE
DRAWN BY	
CHECKED BY	
NOTED BY	
NO.	

FED. ROAD DIST. NO.	STATE	FED. AID PROJ. NO.	FISCAL YEAR	SHEET NO.	TOTAL SHEETS
HAWAII	HAW.	U-FF-078-1(6)	1976	56	142



CW20-1a 48" x 48"



CW20-2d 48" x 48"



CW20-3b 48" x 48"



CW20-4d 48" x 48"



CW20-5d(L) 48" x 48"



CW20-7c 48" x 48"



CW21-1 30" x 30"



CW21-2 30" x 30"



CW21-3 36" x 36"



CW21-4 36" x 36"



CW21-5 30" x 30"



CW21-6 30" x 30"



CW22-1b 48" x 48"



CW22-2 42" x 36"



CW22-3 42" x 36"



CG20-1(5) 60" x 36"



CG20-2 60" x 24"



CM4-9(R) 30" x 24"



CM4-10(R) 48" x 18"

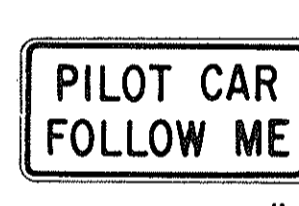

CG20-4 36" x 18"



CW23-1 36" x 36"

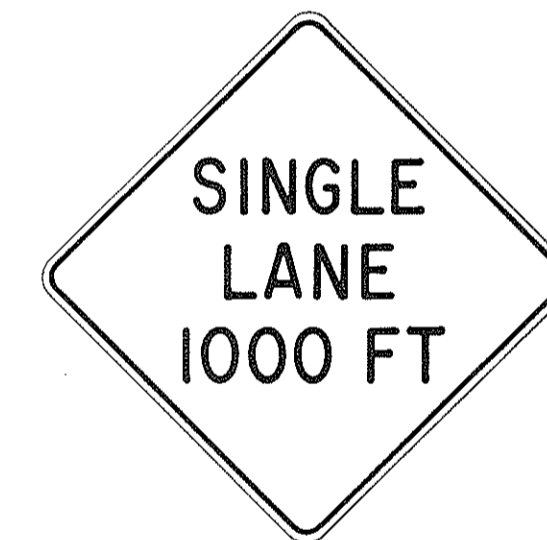

CW23-2b 48" x 48"



CW23-3(R) 48" x 48"

GENERAL NOTES

- Sign details shall conform to the FHWA publications "Manual on Uniform Traffic Control Devices for Streets and Highways," 1971, and "Standard Highway Signs," 1972, and as amended.
- All construction signs shall be reflectorized with high intensity reflective sheeting.
- All construction signs shall have 3/8" bolt holes drilled at appropriate locations.
- Numerals in () indicates numerals to be inserted for sign message. (R) or (L) indicates right or left.
- For "CW" series signs, suffixes a,b,c and d are as follows:
a-1500 FT, b-1000 FT, c-500 FT and d-AHEAD.

APPROVAL RECOMMENDED:
Evelyn Tanaka 3/21/72
 TRAFFIC ENGINEER DATE

APPROVED:
William Salsich 2/23/72
 ASSISTANT CHIEF, ENGINEERING DATE

NO.	REVISION	APPROVED BY	DATE
1	Supersedes Sht. DT 104 Approved 12-30-69	HT	3/25/72
2	Revised General Note 1	HT	10/10/74
3	Revised General Note 2	MH	9-16-75

STATE OF HAWAII
 DEPARTMENT OF TRANSPORTATION
 HIGHWAYS DIVISION

STANDARD DETAILS
CONSTRUCTION SIGNS

NOT TO SCALE

SURVEY PLOTTED BY	DATE
DRAWN BY	
CHECKED BY	
DESIGNED BY	
QUANTITIES BY	
CHECKED BY	
ORIGINAL PLAN	
NOTE BOOK	
No.	

FED. ROAD DIST. NO.	STATE	FED. AID PROJ. NO.	FISCAL YEAR	SHEET NO.	TOTAL SHEETS
HAWAII	HAW.	1-FE-078-1(6)	1976	57	142

GENERAL NOTES

1. Marker details shall conform to the FHWA publications "Manual on Uniform Traffic Control Devices for Streets and Highways," 1971, "Standard Alphabets for Highway Signs," 1966, and "Standard Highway Signs," 1972, and as amended.
2. All markers shall be reflectorized unless otherwise specified.
3. All markers shall have 3/8" bolt holes drilled at appropriate locations.
4. Numerals in () indicates numerals to be inserted for marker message. (R) or (L) indicates right or left.
5. Sign message of Cardinal Direction Marker (M3 series) shall be denoted by the following:
M3-1 : NORTH
M3-2 : EAST
M3-3 : SOUTH
M3-4 : WEST
6. Markers prefixed with "IM" on the plans shall have a white legend on a blue background.

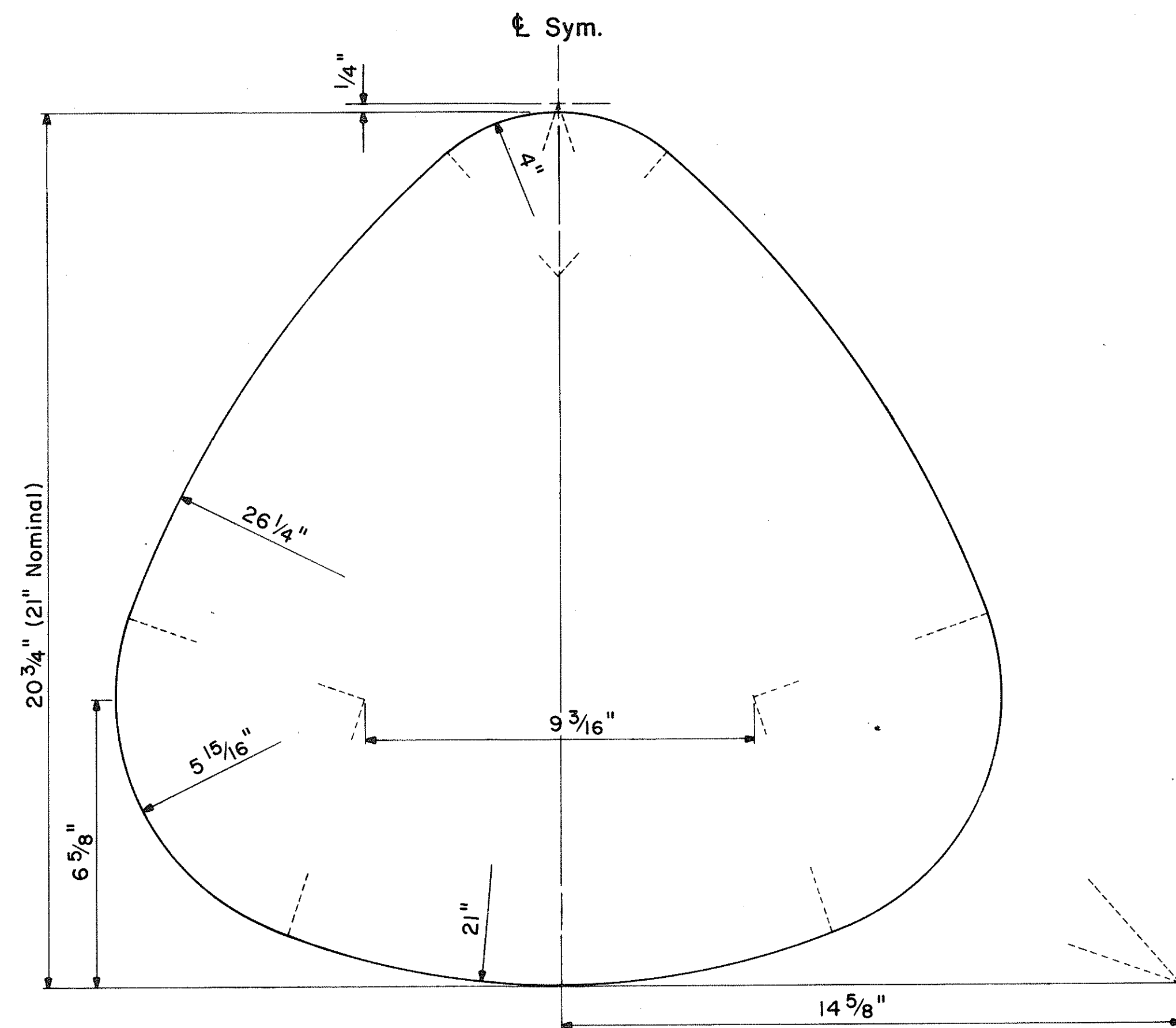

STATE ROUTE MARKER DETAIL

Not to Scale

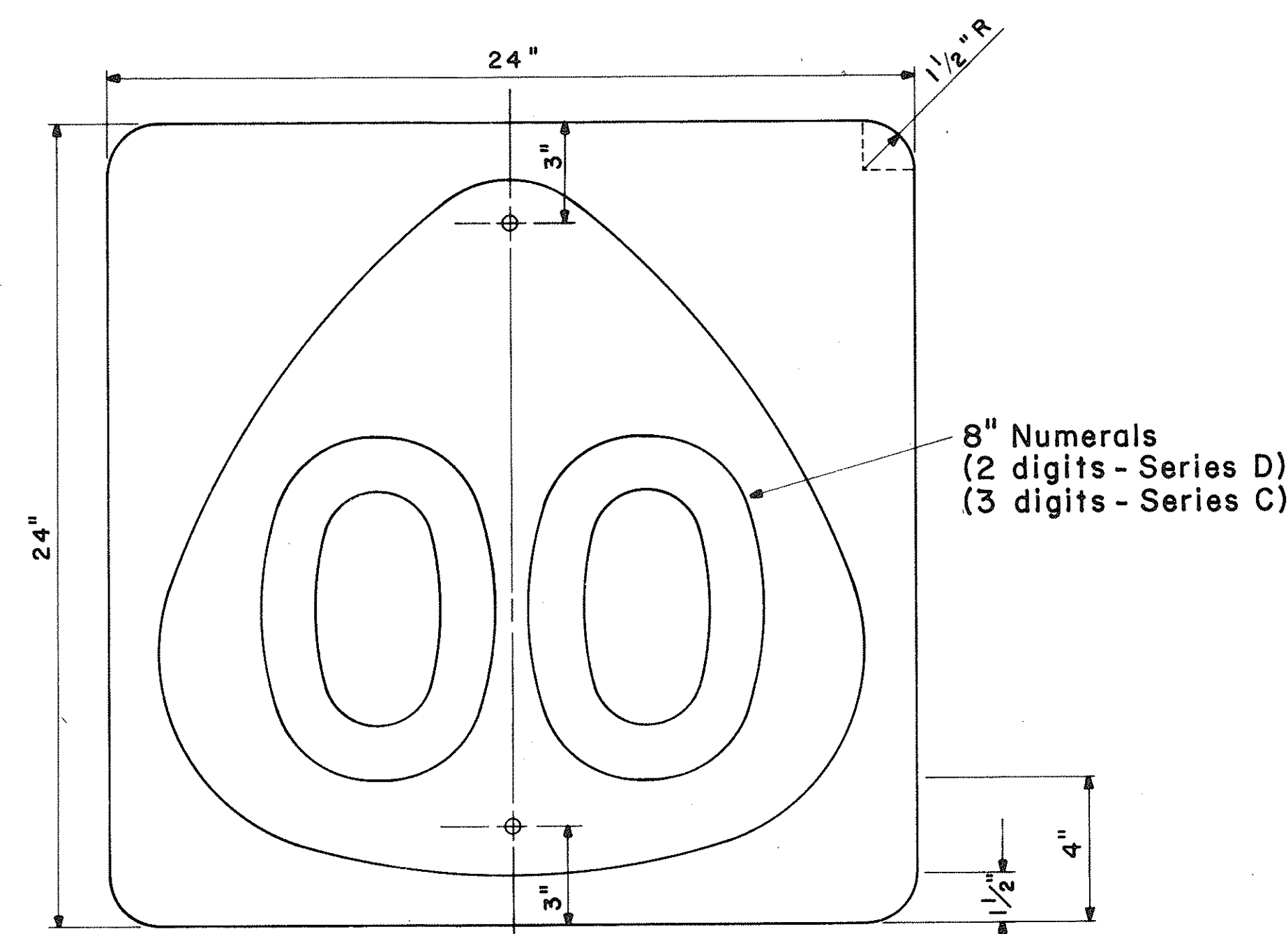

STATE ROUTE MARKER

MI-6 (00) 24" x 24"

Scale: 1/4" = 1"

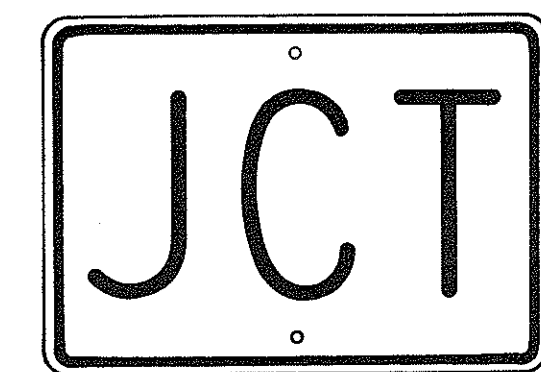

M2-1 21" x 15"

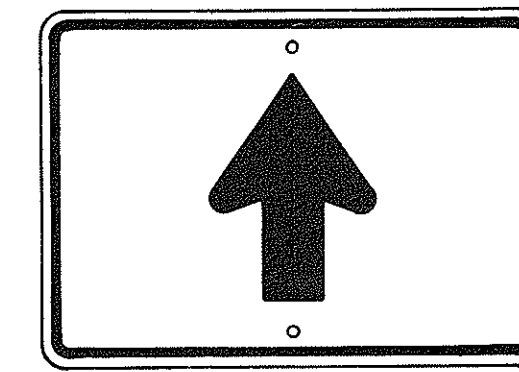

M6-3 21" x 15"

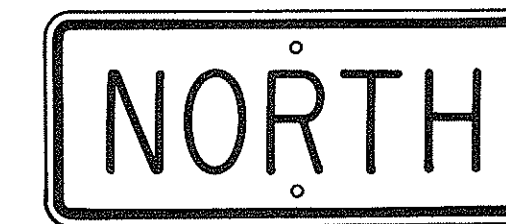

M3-1 24" x 12"
M3-1-A 36" x 18"



M4-1 24" x 12"

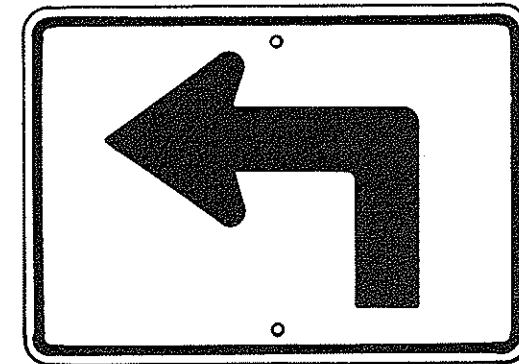

M5-1(L) 21" x 15"

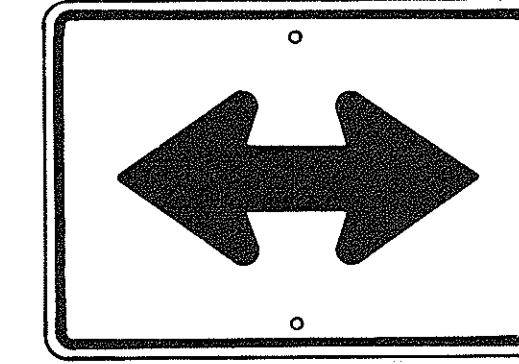

M6-4 21" x 15"

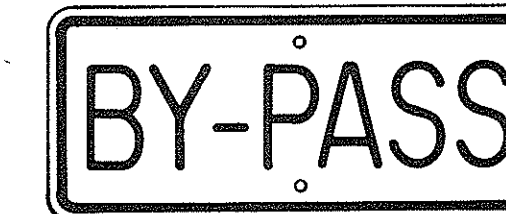

M4-2 24" x 12"

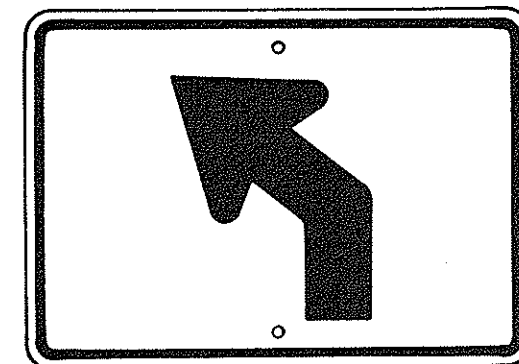

M5-2(L) 21" x 15"

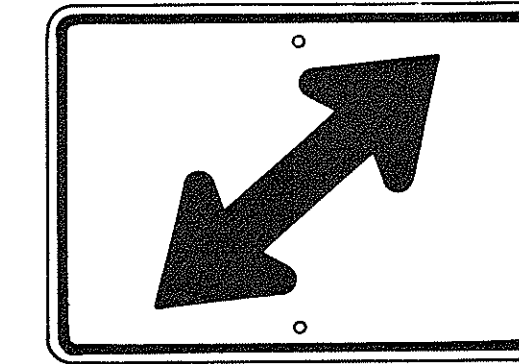

M6-5(R) 21" x 15"

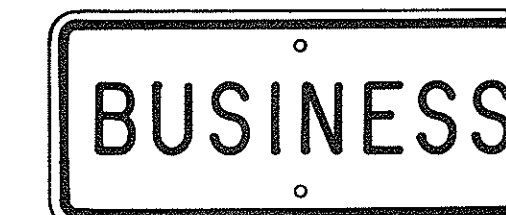

M4-3 24" x 12"



M4-5 24" x 12"

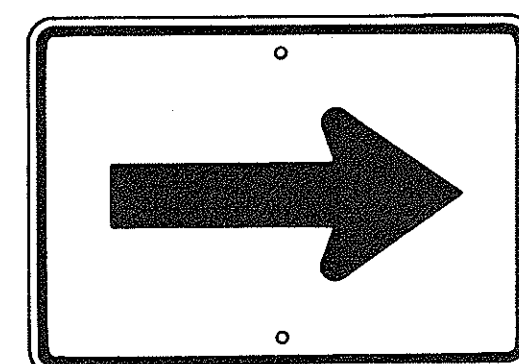

M6-1 21" x 15"

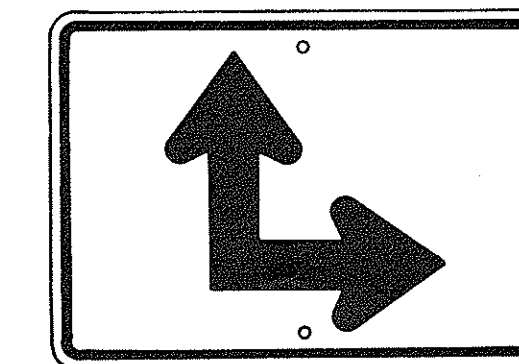

M6-6(R) 21" x 15"

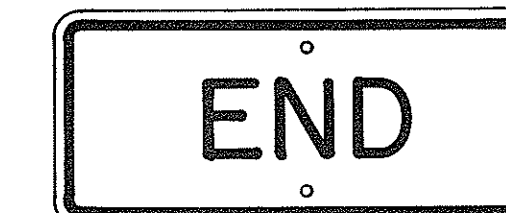

M4-6 24" x 12"

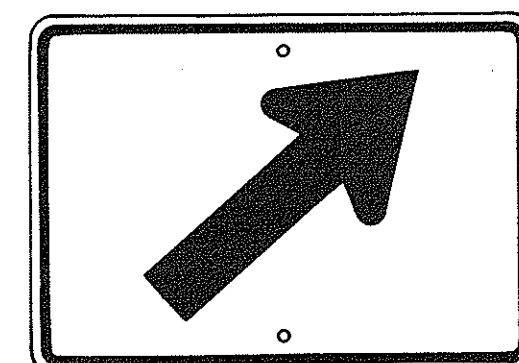

M6-2(R) 21" x 15"

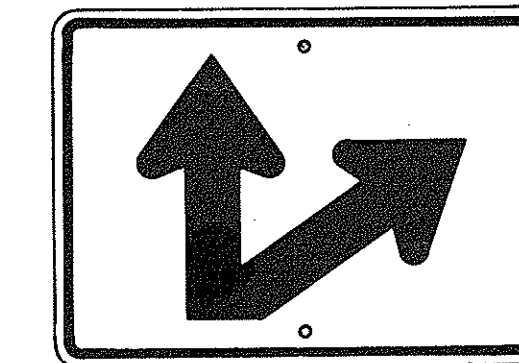

M6-7(R) 21" x 15"

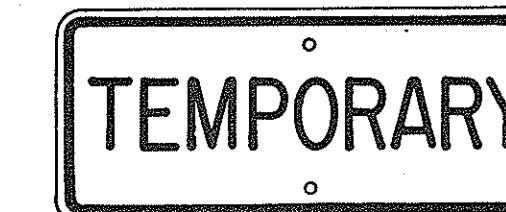

M4-7 24" x 12"



M4-8 24" x 12"

AUXILIARY MARKERS

Not to Scale

APPROVAL RECOMMENDED:

Eishi Tanaka 6/6/72
TRAFFIC ENGINEER DATE

APPROVED:

Abul K. Siddiqui 6-1-72
ASSISTANT CHIEF, ENGINEERING DATE

NO.	REVISION	APPROVED BY	DATE
1	Supersedes Sht. DT 105 Approved 12-30-69	HT	6/1/72
2	Revised General Note 1	HT	10/16/74

STATE OF HAWAII
DEPARTMENT OF TRANSPORTATION
HIGHWAYS DIVISION

STANDARD DETAILS
STATE ROUTE MARKER
AND AUXILIARY MARKERS

Scale: As Shown
SHEET No. 57 OF 13 SHEETS DT 105

SURVEY PLOTTED BY	DATE
DRAWN BY	
TRACED BY	
QUANTITIES BY	
CHECKED BY	
ORIGINAL PLAN	
NOTE BOOK	
No.	

FED. ROAD DIST. NO.	STATE	FED. AID PROJ. NO.	FISCAL YEAR	SHEET NO.	TOTAL SHEETS
HAWAII	HAW.	U-FE-078-1(6)	1976	58	142

* For moment calculations only. Post shall be from top of foundation to top of sign.
 ** For fills with side slopes flatter than 4:1, Minimum Footing Depth shall be 4½ feet.

POST SIZE	MAXIMUM SIGN AREA	POST HEIGHT TOP OF FOUNDATION TO CENTER OF SIGN *	DIMENSIONS											ANCHOR BOLT DIA.	MINIMUM FOOTING DEPTH		
			H	J	K	M	N	O	P	S	T	U	V		W	CUT	FILL**
8 J 10	50 sq. ft.	14'	14"	5"	24"	17¼"	15⅝"	6"	1¼"	9"	6"	10"	2"	1"	1⅝" ∅	4½'	4½'
8 WF 24	90 sq. ft.	21'															5'
8 WF 35	190 sq. ft.	15'	16½"	6¾"	30"	20"	1¾"	6"	1⅜"	11¾"	6½"	10"	1¾"	1"	1¼" ∅	6'	7'
10 WF 45	190 sq. ft.	25'															
10 WF 45	200 sq. ft.	25'															
12 WF 50	230 sq. ft.	25'															
12 WF 50	250 sq. ft.	23'															

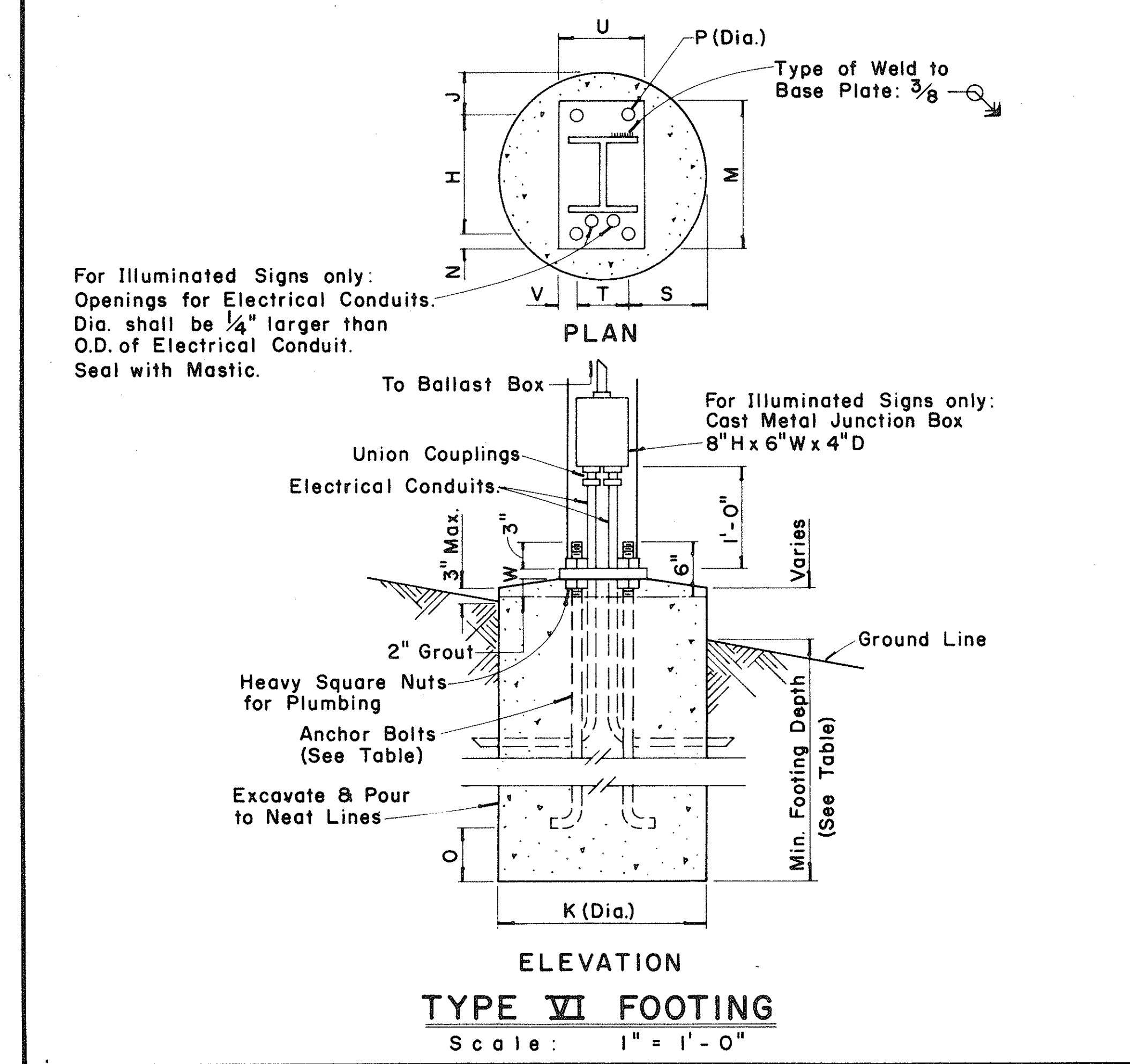
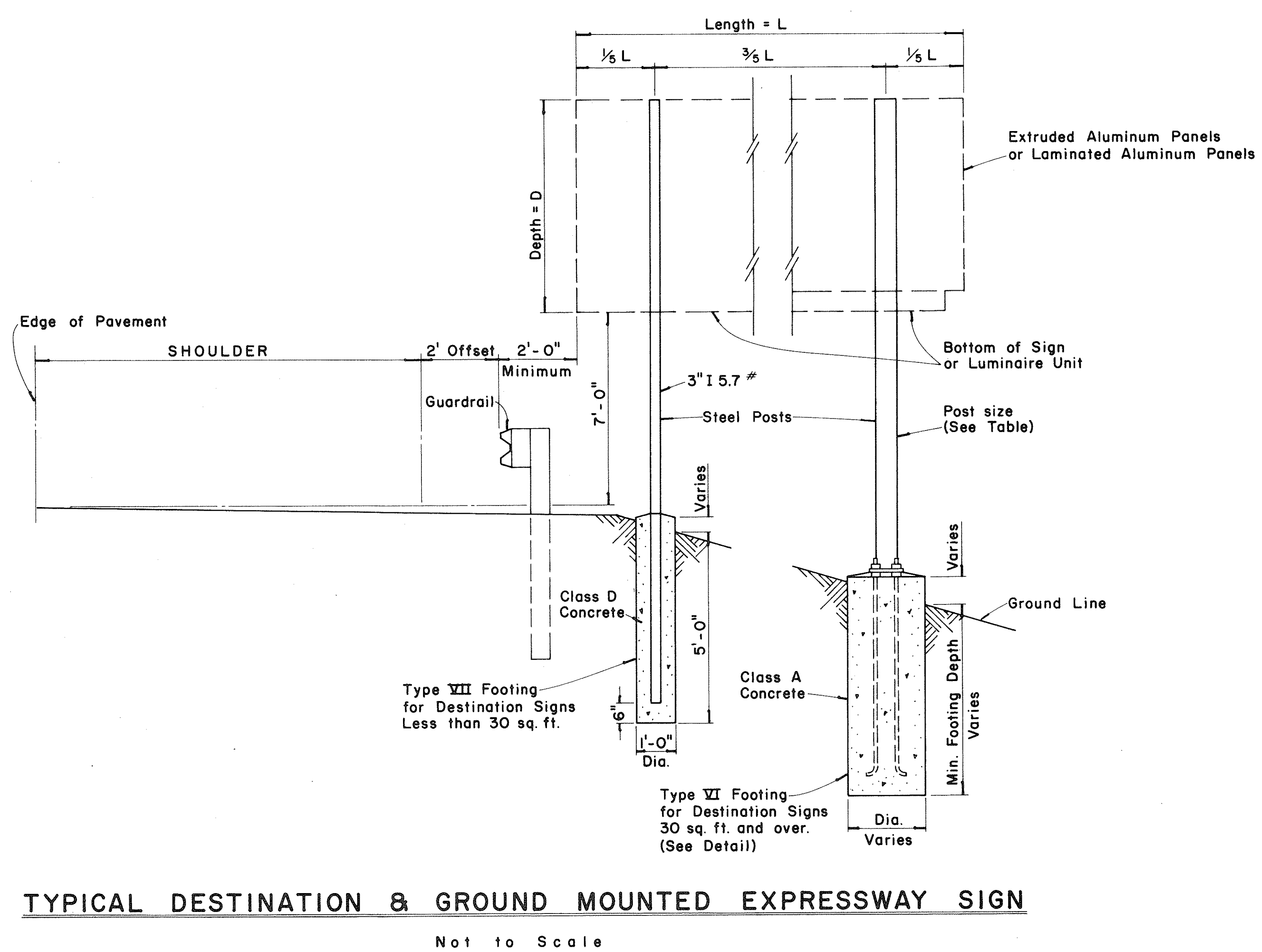
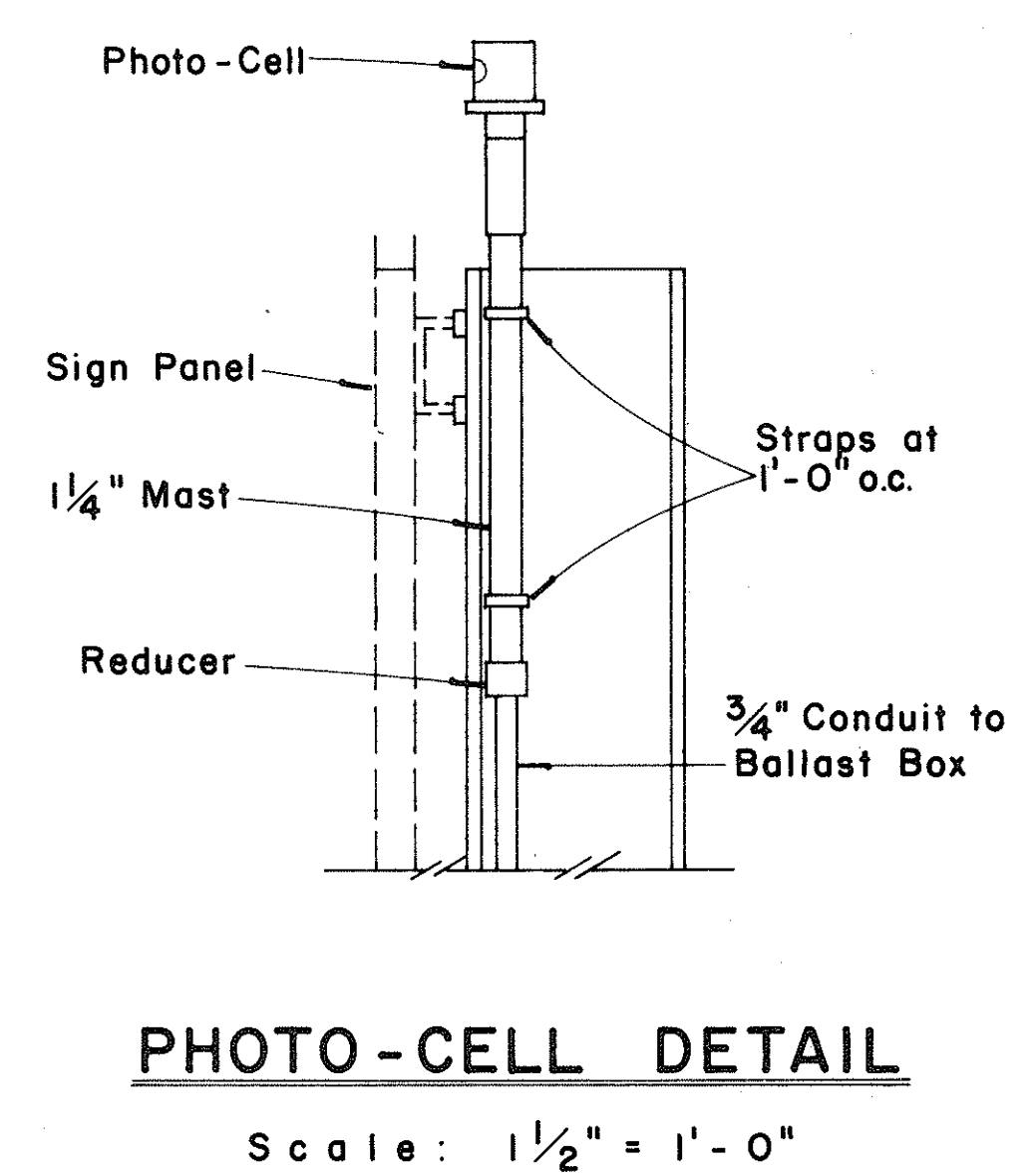
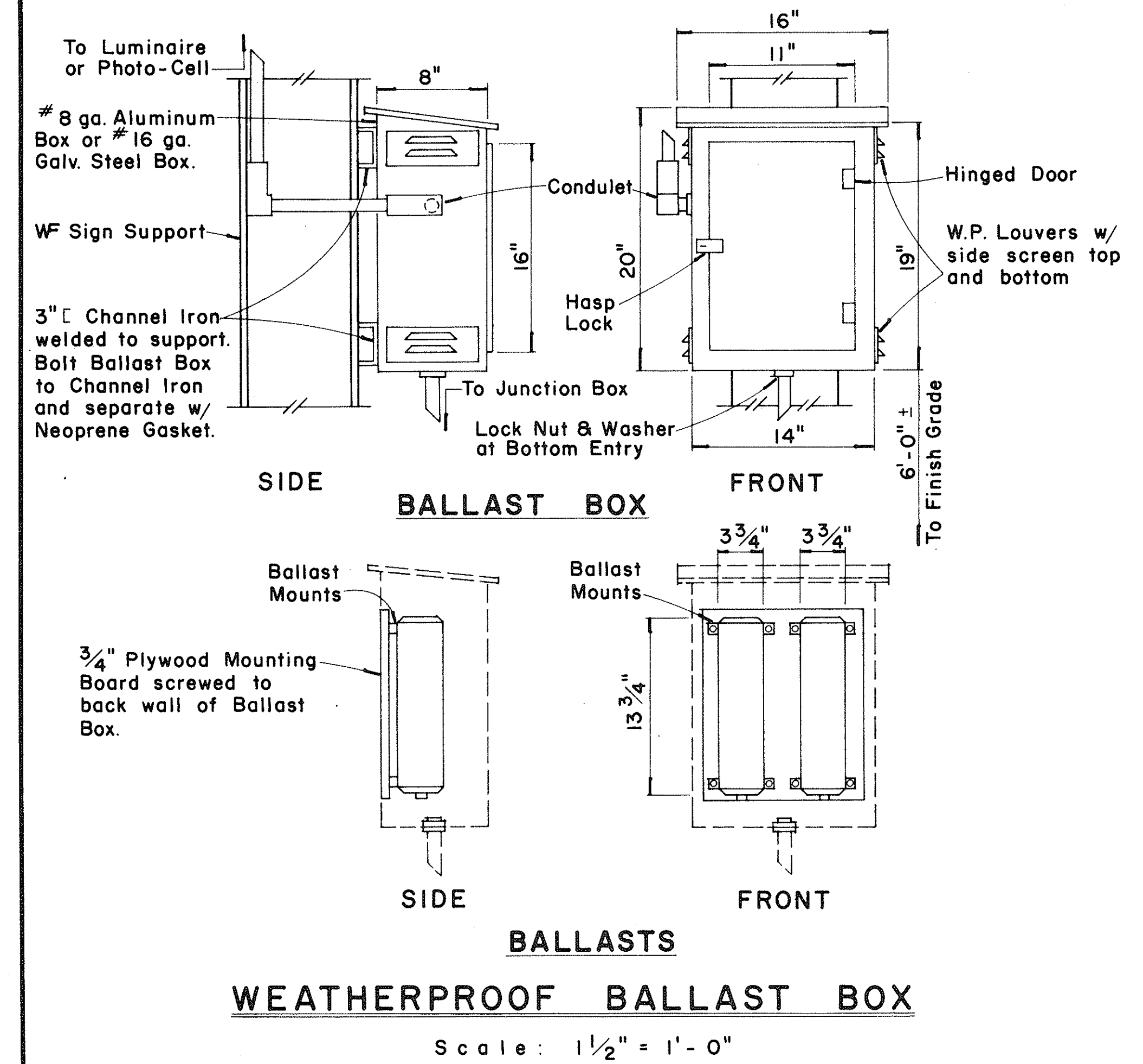

APPROVAL RECOMMENDED:
Erichi Tanaka 12/29/69
 TRAFFIC ENGINEER DATE

APPROVED:
John J. [Signature] 12-30-69
 ASSISTANT CHIEF, ENGINEERING DATE

NO.	REVISION	APPROVED BY	DATE

STATE OF HAWAII
 DEPARTMENT OF TRANSPORTATION
 HIGHWAYS DIVISION

STANDARD DETAILS
 DESTINATION & GROUND MOUNTED
 EXPRESSWAY SIGNS

Scale: As Shown
 SHEET No. 7 OF 13 SHEETS DT 203

DATE: _____
 SURVEY PLOTTED BY: _____
 DRAWN BY: _____
 CHECKED BY: _____
 NOTE BOOK No. _____

FED. ROAD DIST. NO.	STATE	FED. AID PROJ. NO.	FISCAL YEAR	SHEET NO.	TOTAL SHEETS
HAWAII	HAW.	11-FE078-1(6)	1976	59	142

Post Size	Bolt Size & Torque	BASE CONNECTION DATA TABLE										FUSE PLATE DATA TABLE										FOUNDATION DATA				
		A	B	C	D	E	t1	t2	W	R	F	G	H	J	K	L	N	d1	t3	Bolt Dia.	Wt. of each Fuse Pl.	Stub Length	Stub Projection	Footing Diameter	Bars V Size	
6 B 8.5	5/8" ϕ x 2 3/4" Torque = 450" #	5"	2"	1 1/4"	2 3/4"	1 1/8"	3/4"	1/2"	1/4"	11/32"	3 5/8"	2"	1 1/8"	4"	2 1/4"	7/8"	1/2"	9/16"	1/4"	1/2" ϕ	1.09 #	2'-0"	3"	2'-0"	#5	
6 B 12											3 3/4"	2"	1 1/8"	4"	2 1/4"	7/8"	5/8"	1 1/16"	3/8"	5/8" ϕ	1.60 #	2'-0"	3"	2'-0"	#5	
6 B 15.5											4 1/2"	2 1/2"	1 1/4"	6"	3 1/2"	1 1/4"	3/4"	1 3/16"	1/2"	3/4" ϕ	3.75 #	2'-6"	3"	2'-0"	#6	
8 WF 17											4 1/2"	2 1/2"	1 1/4"	5 1/4"	2 3/4"	1 1/4"	3/4"	1 3/16"	1/2"	3/4" ϕ	3.27 #	2'-6"	3"	2'-0"	#7	
8 WF 20	3/4" ϕ x 3 1/2" Torque = 750" #	6"	2 1/4"	1 3/8"	3 1/2"	1 1/4"	1"	3/4"	5/16"	13/32"	4 7/8"	2 1/2"	1 1/2"	5 1/4"	2 3/4"	1 1/4"	7/8"	1 5/16"	9/16"	7/8" ϕ	3.93 #	3'-0"	2 1/2"	2'-0"	#8	
10 WF 21											5 3/8"	3"	1 1/2"	5 3/4"	2 3/4"	1 1/2"	7/8"	1 5/16"	9/16"	7/8" ϕ	4.75 #	3'-0"	2 1/2"	2'-0"	#9	
10 WF 25											5 3/8"	3"	1 1/2"	5 3/4"	2 3/4"	1 1/2"	7/8"	1 5/16"	9/16"	7/8" ϕ	4.79 #	3'-0"	2 1/2"	2'-0"	#10	
12 WF 27	5 3/8"	3"	1 1/2"	6 1/2"	3 1/2"	1 1/2"	7/8"	1 5/16"	9/16"	7/8" ϕ	5.42 #	3'-0"	2 1/2"	2'-0"	#11											
3 I 5.7	1/2" ϕ x 2 1/2" Torque = 200" #	SEE DETAIL "A"										3 1/8"	1 1/2"	1 1/8"	2 5/8"	1 1/2"	9/16"	1/2"	9/16"	1/4"	1/2" ϕ	0.64 #	1'-6"	3 1/2"	1'-6"	#5
4 I 7.7		3 1/8"	1 1/2"	1 1/8"	2 5/8"	1 1/2"	9/16"	1/2"	9/16"	1/4"	1/2" ϕ	0.64 #	1'-6"	3 1/2"	1'-6"	#5										

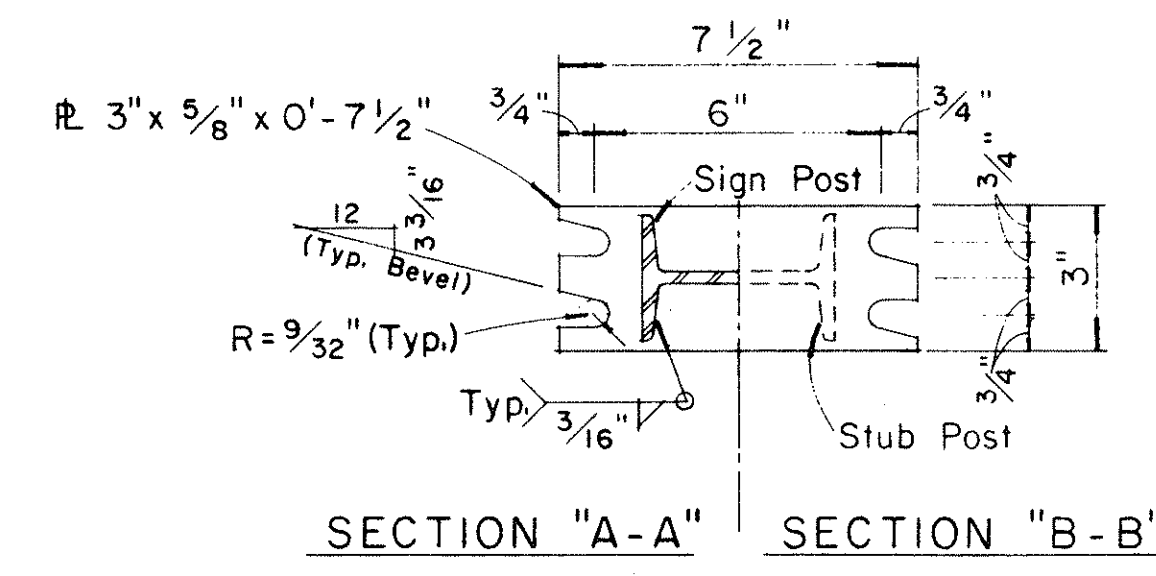
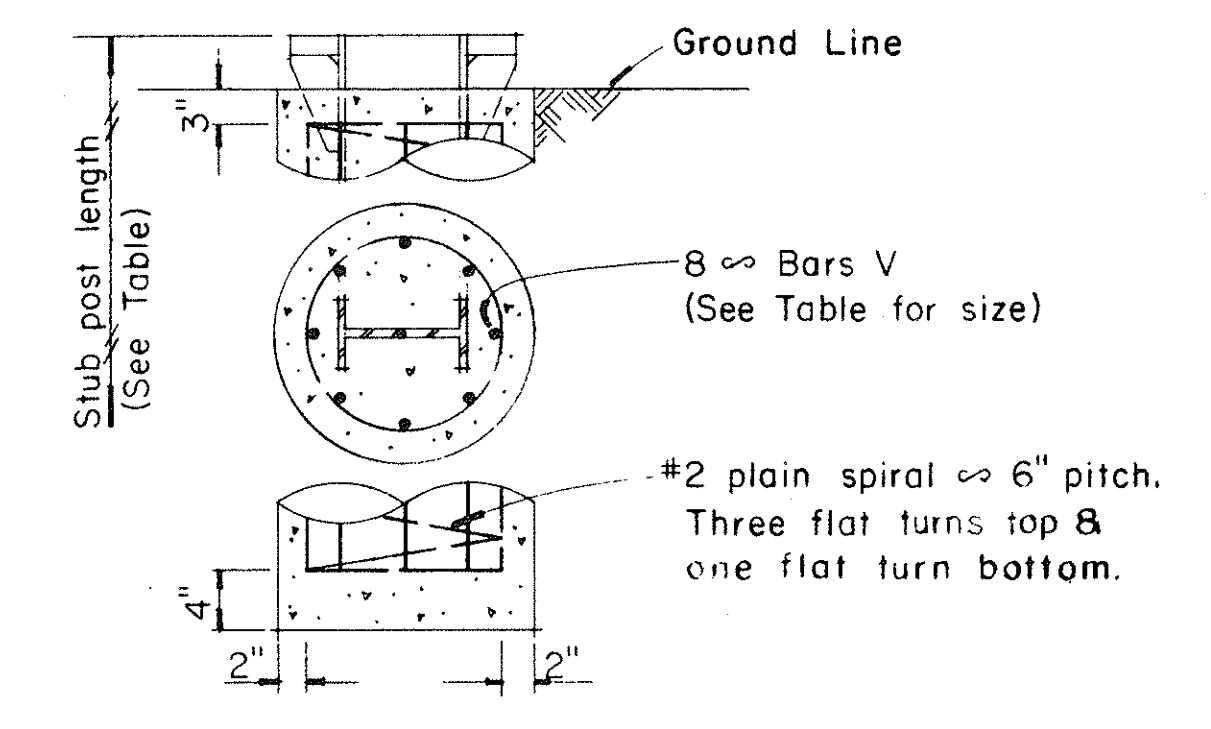
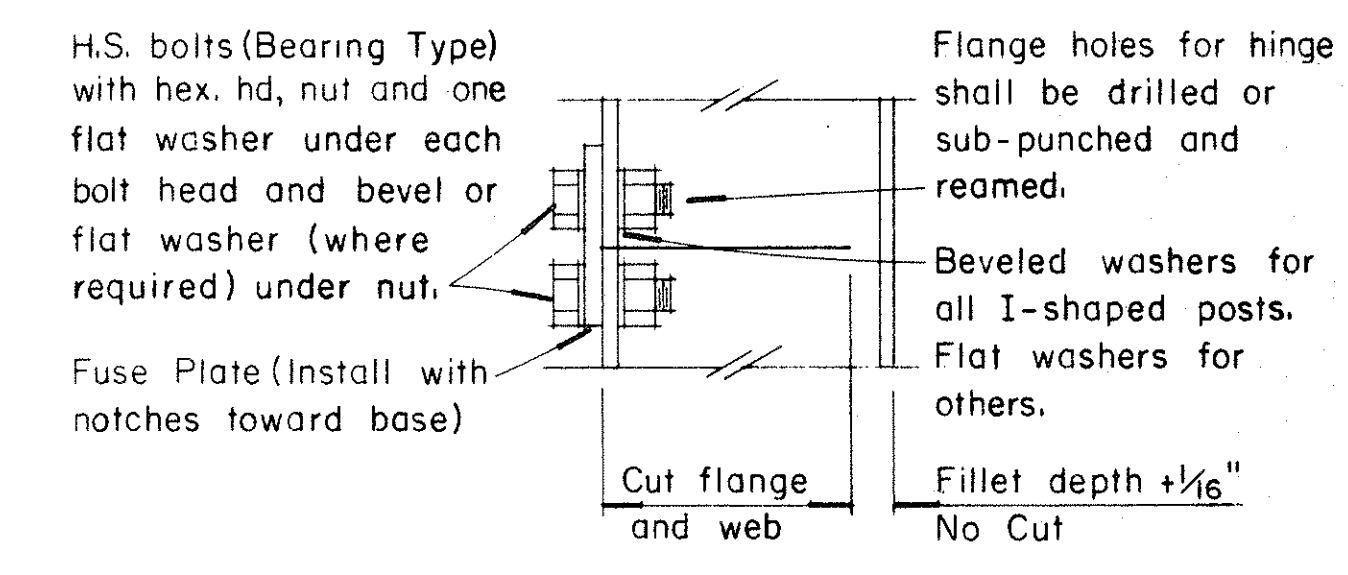
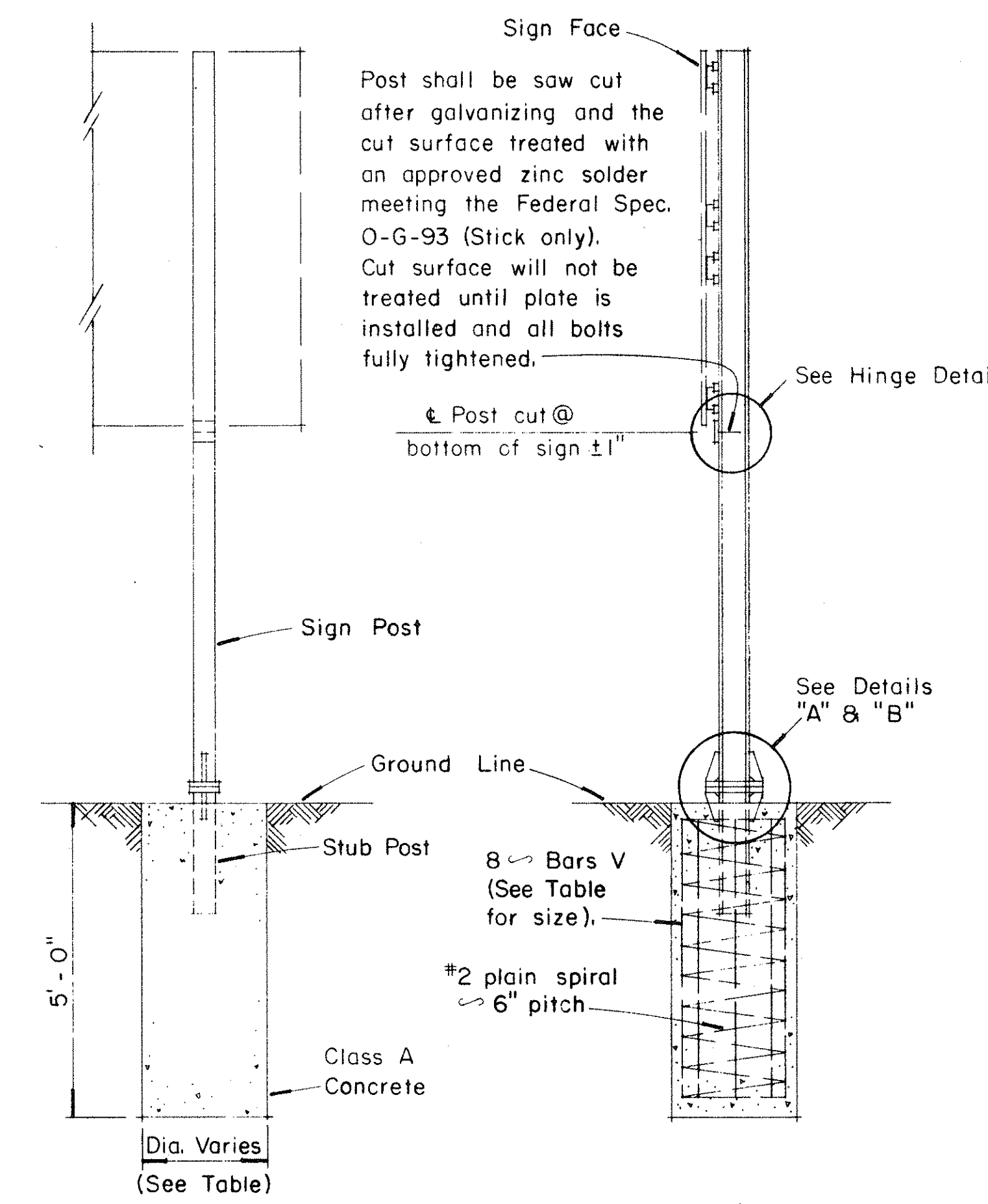

NOTE: Sections shown are for installations on right shoulder and in gore. Reverse plate slot bevels for installations on left shoulder.

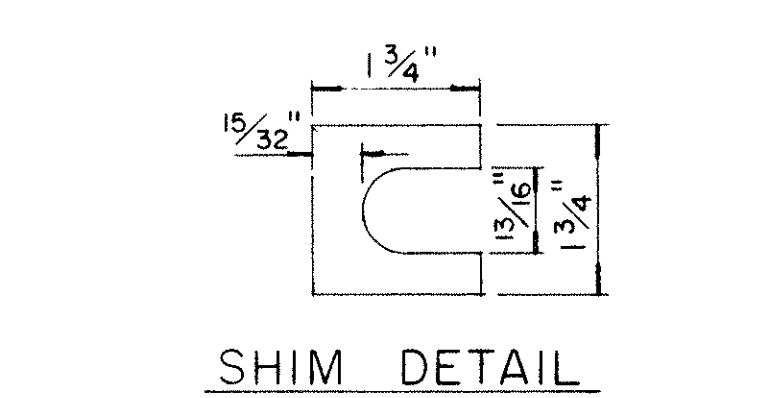
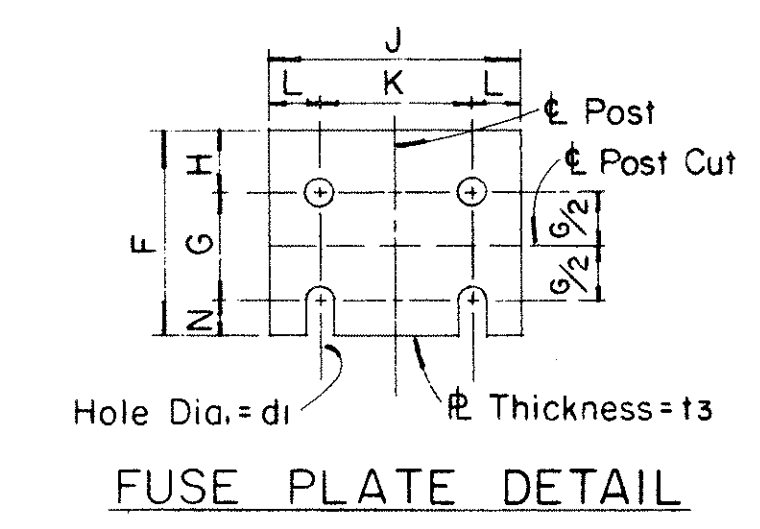
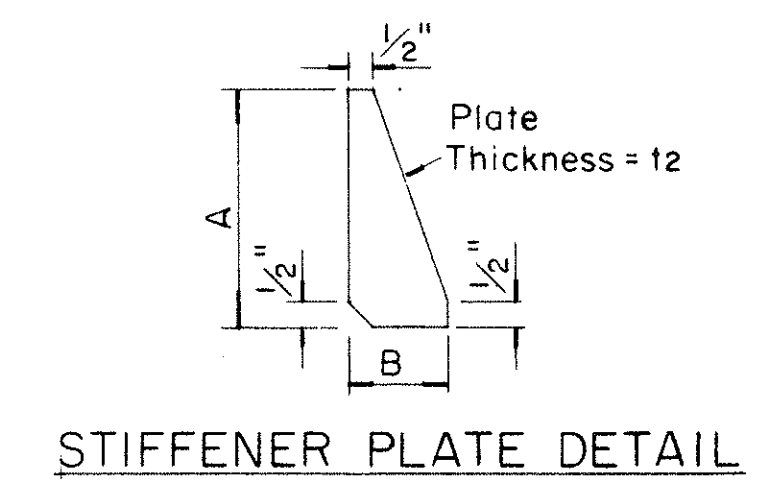
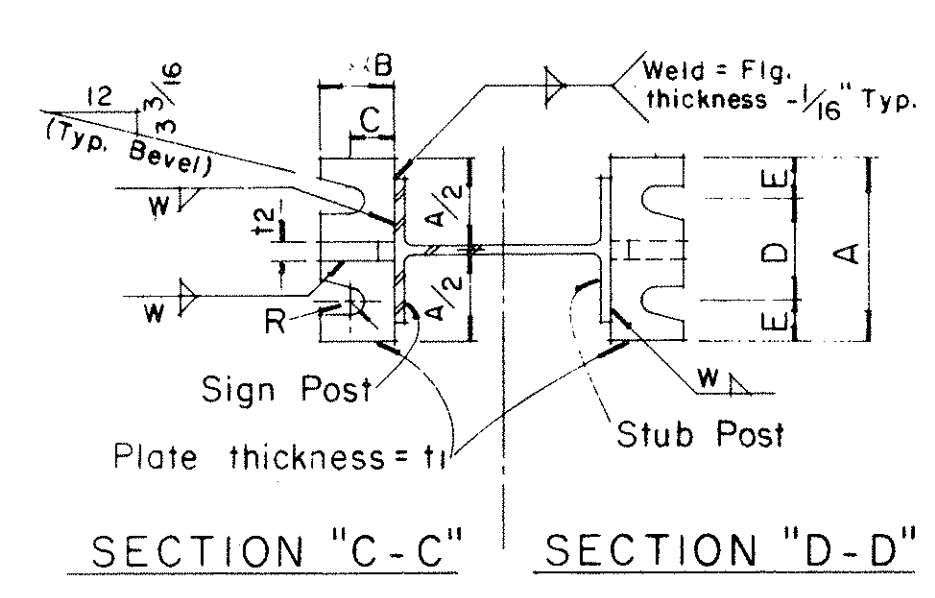

GENERAL NOTES

- Design conforms with AASHTO Specifications for the design and Construction of Structural Supports for Highway Signs.
- Materials and Fabrication shall conform to the requirements of the Standard Specifications and Special Provisions.
- All holes shall be drilled. All plate cuts shall preferably be saw cuts, however; flame cutting will be permitted provided all edges are ground. Metal projecting beyond the plane of the plate face will not be tolerated.
- Tighten the high strength bolts in the base connection only to the torque shown, do not overtighten. All bolts other than high strength bolts shall conform to ASTM A 307, Class A.
- All structural steel, bolts, nuts and washers shall be galvanized as per the Standard Specifications and Special Provisions. Structural steel to be galvanized after fabrication except as noted.
- Structural steel shall conform with with the requirements of ASTM A 441
- Galvanizing of all posts shall be projection above concrete plus 6" minimum.
- All friction fuse bolts shall be tightened in the shop following a method approved by the Engineer. Tightening shall be to such a degree as to obtain the following minimum residual tension in each bolt:

Bolt Size	Min. Tension	Bolt Size	Min. Tension
1/2" ϕ	12050 Lbs.	3/4" ϕ	28400 Lbs.
5/8" ϕ	19200 Lbs.	7/8" ϕ	36050 Lbs.

APPROVAL RECOMMENDED:
Eiichi Tanaka 12/29/69
 TRAFFIC ENGINEER DATE

APPROVED:
John J. Stahl 12-30-69
 ASSISTANT CHIEF, ENGINEERING DATE

NO.	REVISION	APPROVED BY	DATE

STATE OF HAWAII
 DEPARTMENT OF TRANSPORTATION
 HIGHWAYS DIVISION

STANDARD DETAILS
BREAK-AWAY SIGN SUPPORTS
FOR
GROUND MOUNTED GUIDE SIGNS

Not to Scale

SURVEY PLOTTED BY: _____
 DRAWN BY: _____
 DESIGNED BY: _____
 CHECKED BY: _____
 ORIGINAL PLAN: _____
 NOTE BOOK: _____
 No. _____

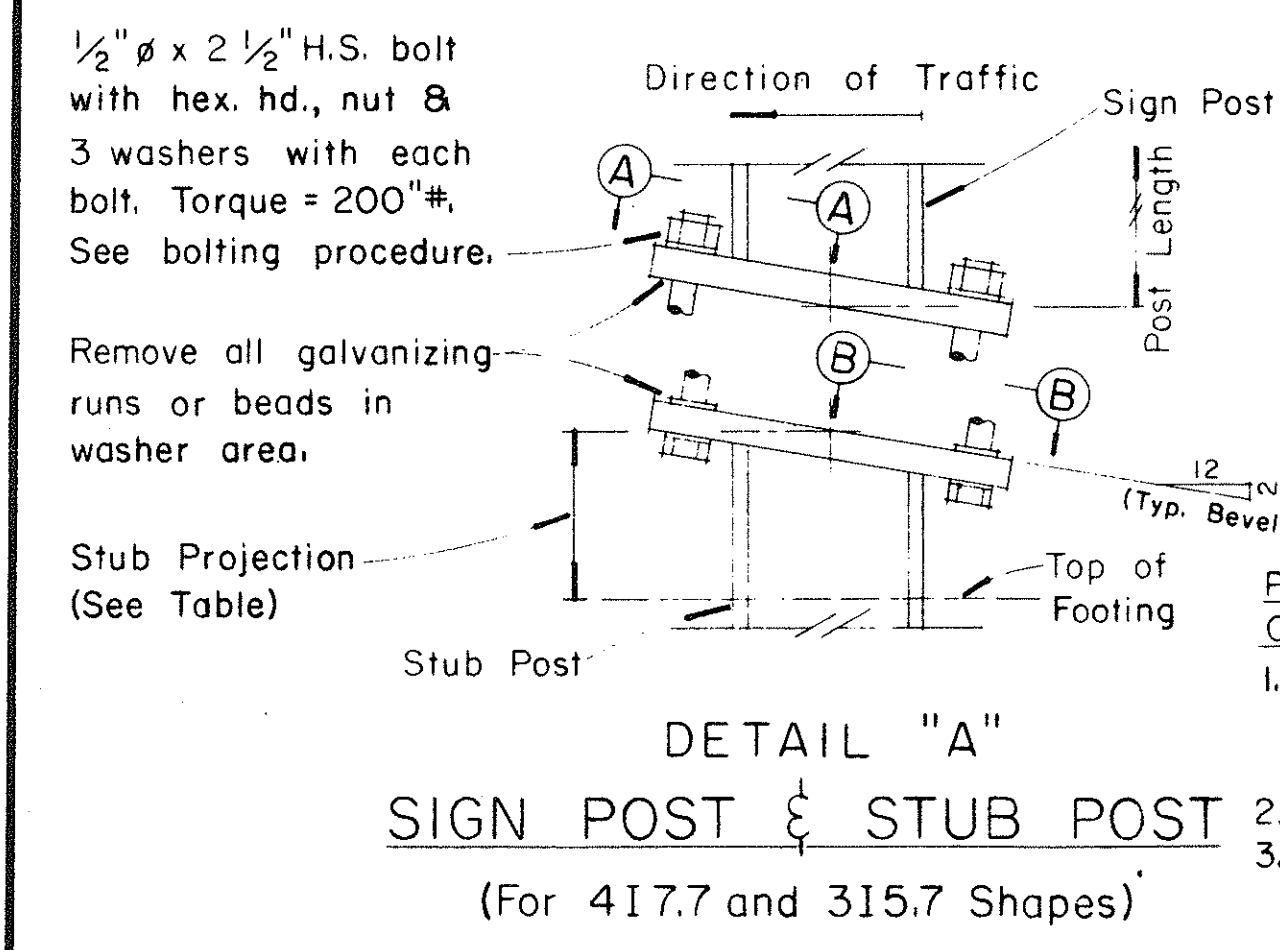

- PROCEDURE FOR ASSEMBLY OF BASE CONNECTION:
- Assemble post to stub with bolts and with one flat washer on each bolt between plates.
 - Shim as required to plumb post.
 - Tighten all bolts the max. possible with 12" to 15" wrench to bed washers & shims and to clean bolt threads then loosen each bolt in turn & retighten bolts in systematic order to prescribed torque. (See Table)
 - Burr threads at junction with nut using a center punch to prevent nut loosening.

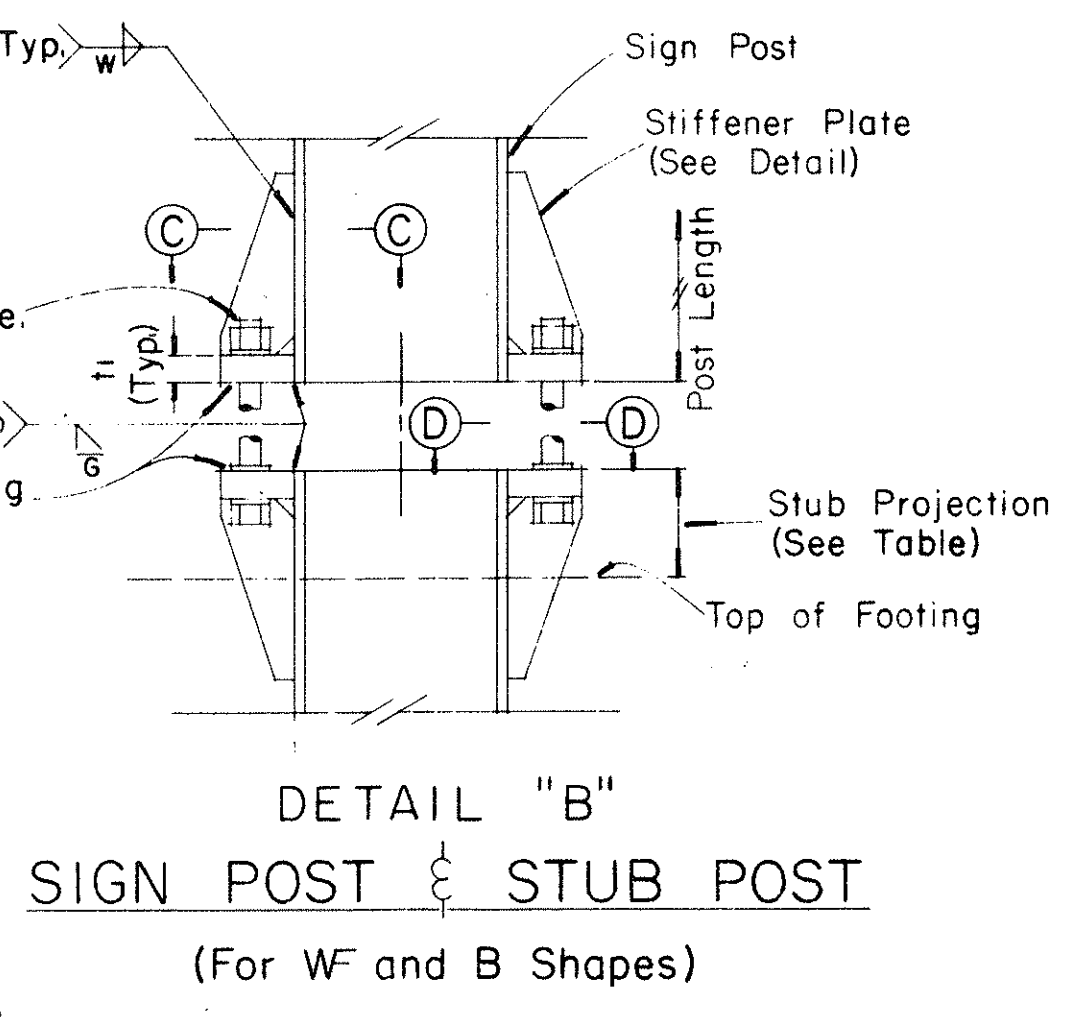

FED. ROAD DIST. NO.	STATE	FED. AID PROJ. NO.	FISCAL YEAR	SHEET NO.	TOTAL SHEETS
HAWAII	HAW.	U-FF-078-1(6)	1976	60	142

(GROUND MOUNTED SIGNS)
SUPPORT SPACING TABLE

PANEL THICK.	LENGTH OF SIGN	NO. OF SUPPORTS	OVERHANG		SUPPORT SPACING
			A	B	
1"	6'-0"	2	12"	48"	
1"	6'-6"	2	15"	48"	
1"	7'-0"	2	15"	54"	
1"	7'-6"	2	18"	54"	
1"	8'-0"	2	18"	60"	
1"	8'-6"	2	20"	62"	
1"	9'-0"	2	22"	64"	
1"	9'-6"	2	23"	68"	
1"	10'-0"	2	24"	72"	
1"	10'-6"	2	24"	78"	
1"	11'-0"	2	24"	84"	
1"	11'-6"	2	27"	84"	
1"	12'-0"	2	30"	84"	
1"	12'-6"	2	30"	90"	
1"	13'-0"	2	30"	96"	
1"	13'-6"	2	30"	102"	
1"	14'-0"	2	30"	108"	
1"	14'-6"	2	36"	102"	
1"	15'-0"	2	36"	108"	
2.5"	15'-6"	2	36"	114"	
2.5"	16'-0"	2	39"	114"	
2.5"	16'-6"	2	39"	120"	
2.5"	17'-0"	2	39"	126"	
2.5"	17'-6"	2	42"	126"	
2.5"	18'-0"	2	42"	132"	
2.5"	18'-6"	2	45"	132"	
2.5"	19'-0"	2	45"	138"	
2.5"	19'-6"	2	45"	144"	
2.5"	20'-0"	2	48"	144"	
2.5"	20'-6"	2	48"	150"	
2.5"	21'-0"	2	51"	150"	
2.5"	21'-6"	2	51"	156"	
2.5"	22'-0"	2	51"	162"	
2.5"	22'-6"	2	54"	162"	
2.5"	23'-0"	2	54"	168"	
2.5"	23'-6"	2	54"	174"	
2.5"	24'-0"	2	57"	174"	

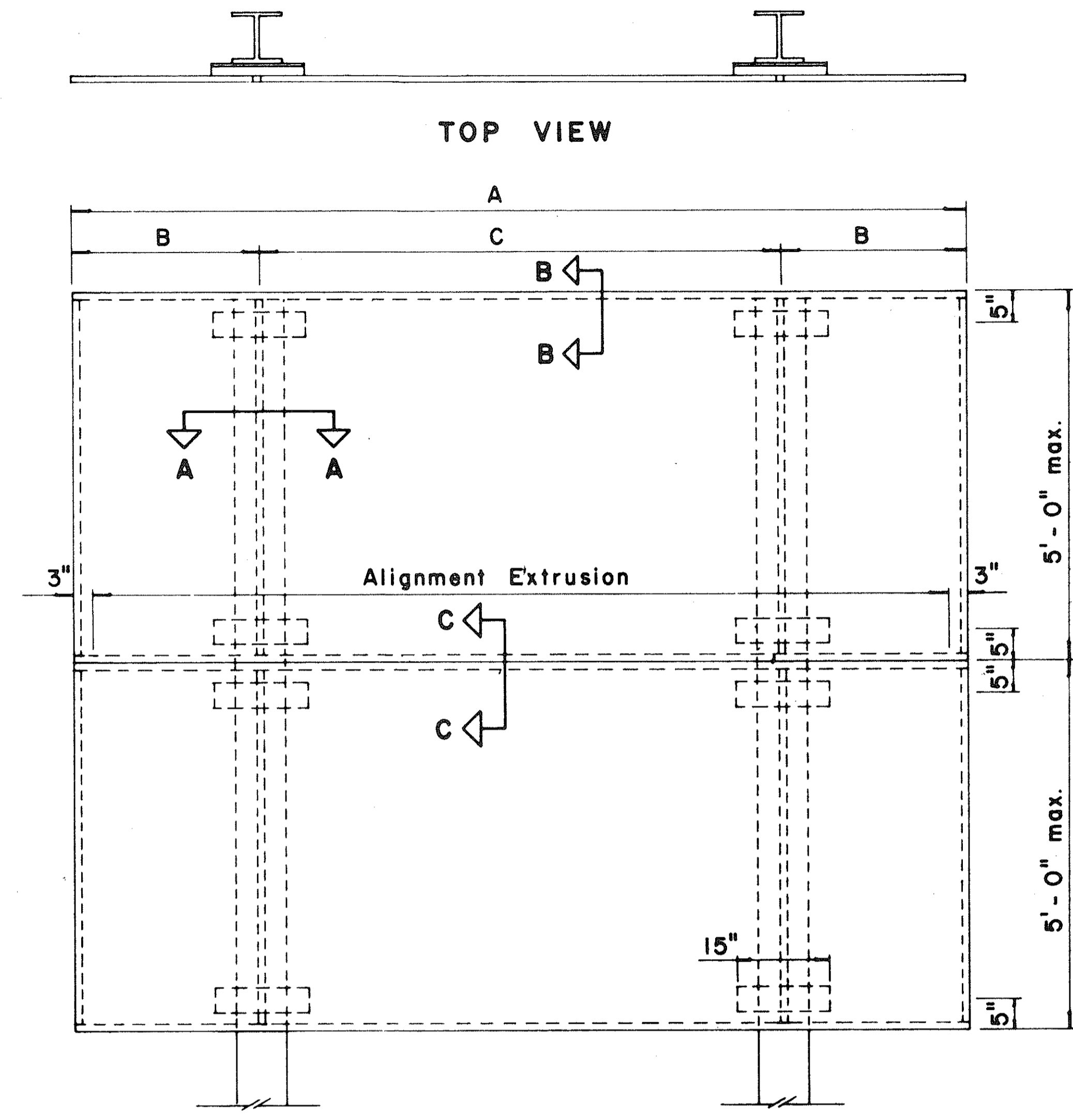

ELEVATION

TYPICAL SIGN ASSEMBLY

Scale: 3/4" = 1'-0"

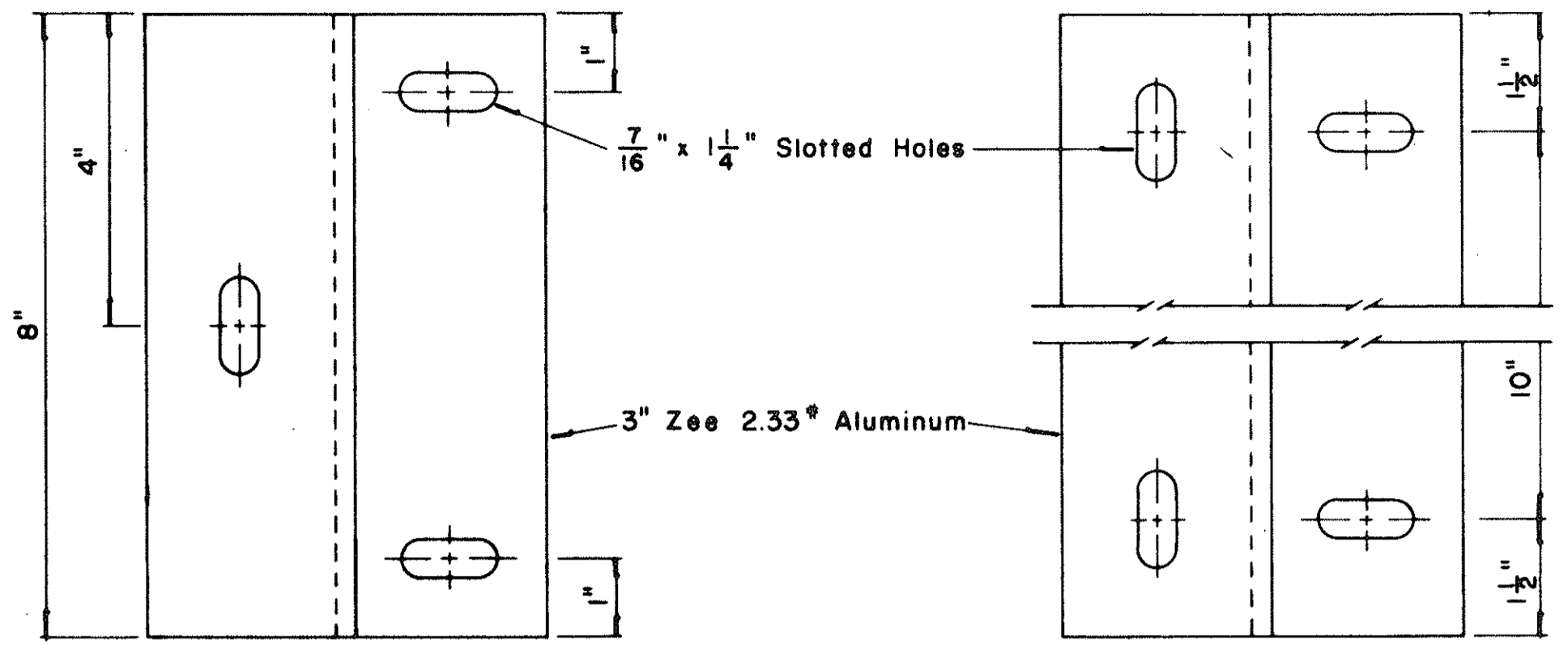

ZEE MOUNTING DETAILS

Scale: 1/2" = 1"

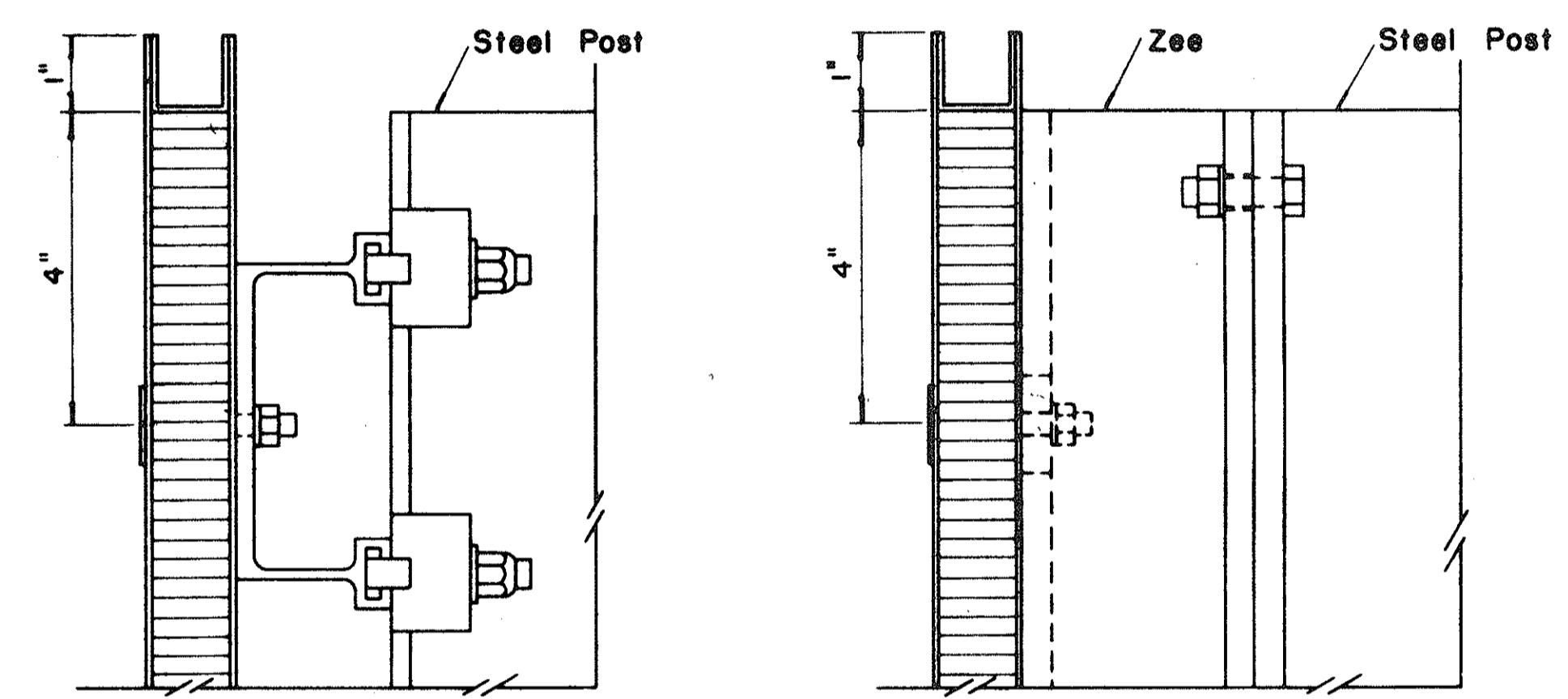

SECTION "B-B" (Alternate)

Scale: 1/2" = 1"

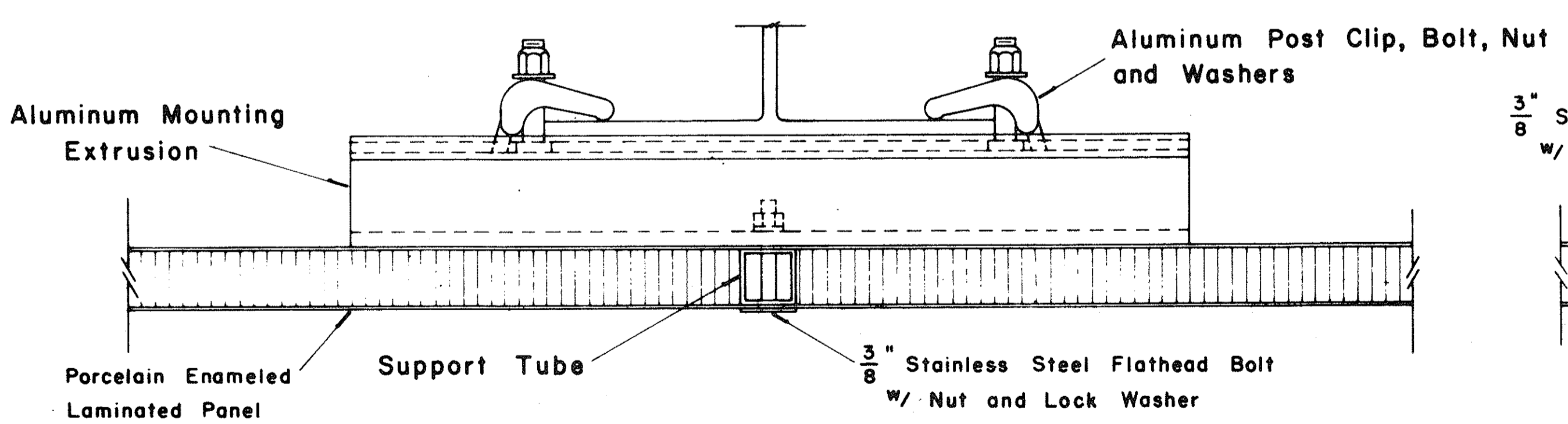

SECTION "A-A"

Scale: 1/2" = 1"

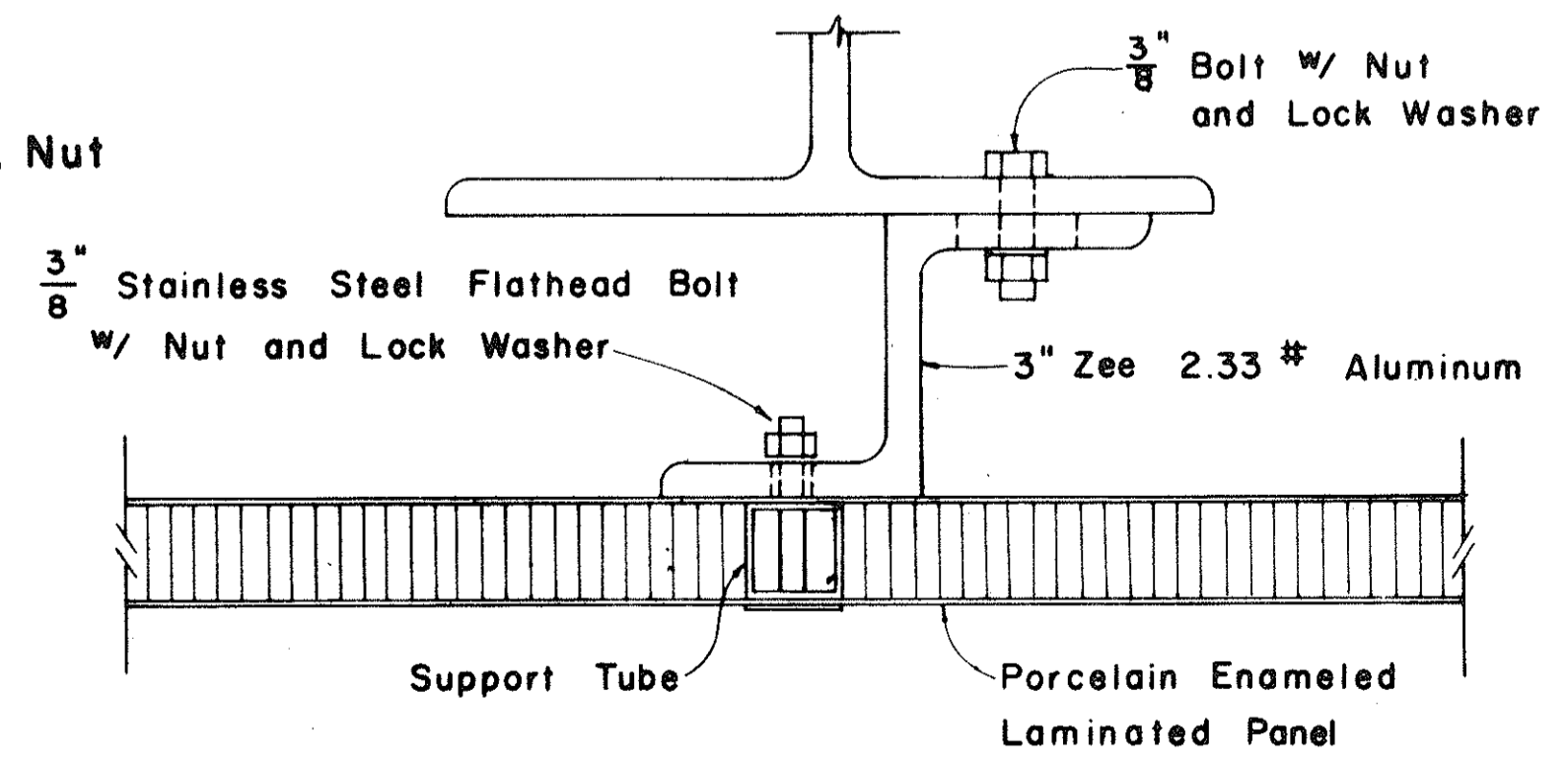

SECTION "A-A" (Alternate)

Scale: 1/2" = 1"

APPROVAL RECOMMENDED:
Eishi Tanaka 12/29/69
TRAFFIC ENGINEER DATE

APPROVED:
John J. [Signature] 12-30-69
ASSISTANT CHIEF, ENGINEERING DATE

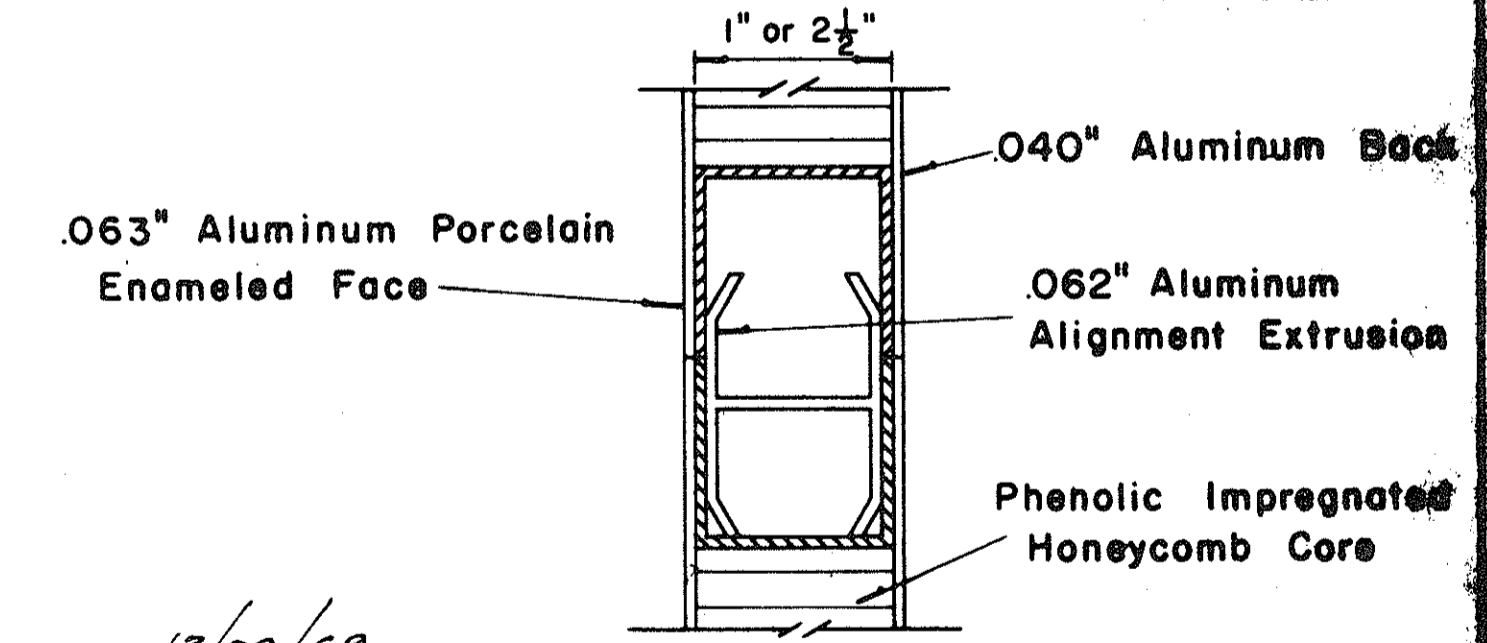

CLOSURE DETAIL SECTION "C-C" FULL SCALE

NO.	REVISION	APPROVED BY	DATE

STATE OF HAWAII
DEPARTMENT OF TRANSPORTATION
HIGHWAYS DIVISION

STANDARD DETAILS
LAMINATED ALUMINUM
SIGN PANELS
(GROUND MOUNTED)

Scale: As Shown

QUANTITY SLOTTED BY: _____ DATE: _____
 ORIGINAL PLAN: _____ DRAWN BY: _____
 NOTE BOOK: _____ DESIGNED BY: _____
 CHECKED BY: _____

FED. ROAD DIST. NO.	STATE	FED. AID PROJ. NO.	FISCAL YEAR	SHEET NO.	TOTAL SHEETS
HAWAII	HAW.	U-FE-078-1(6)	1976	61	142

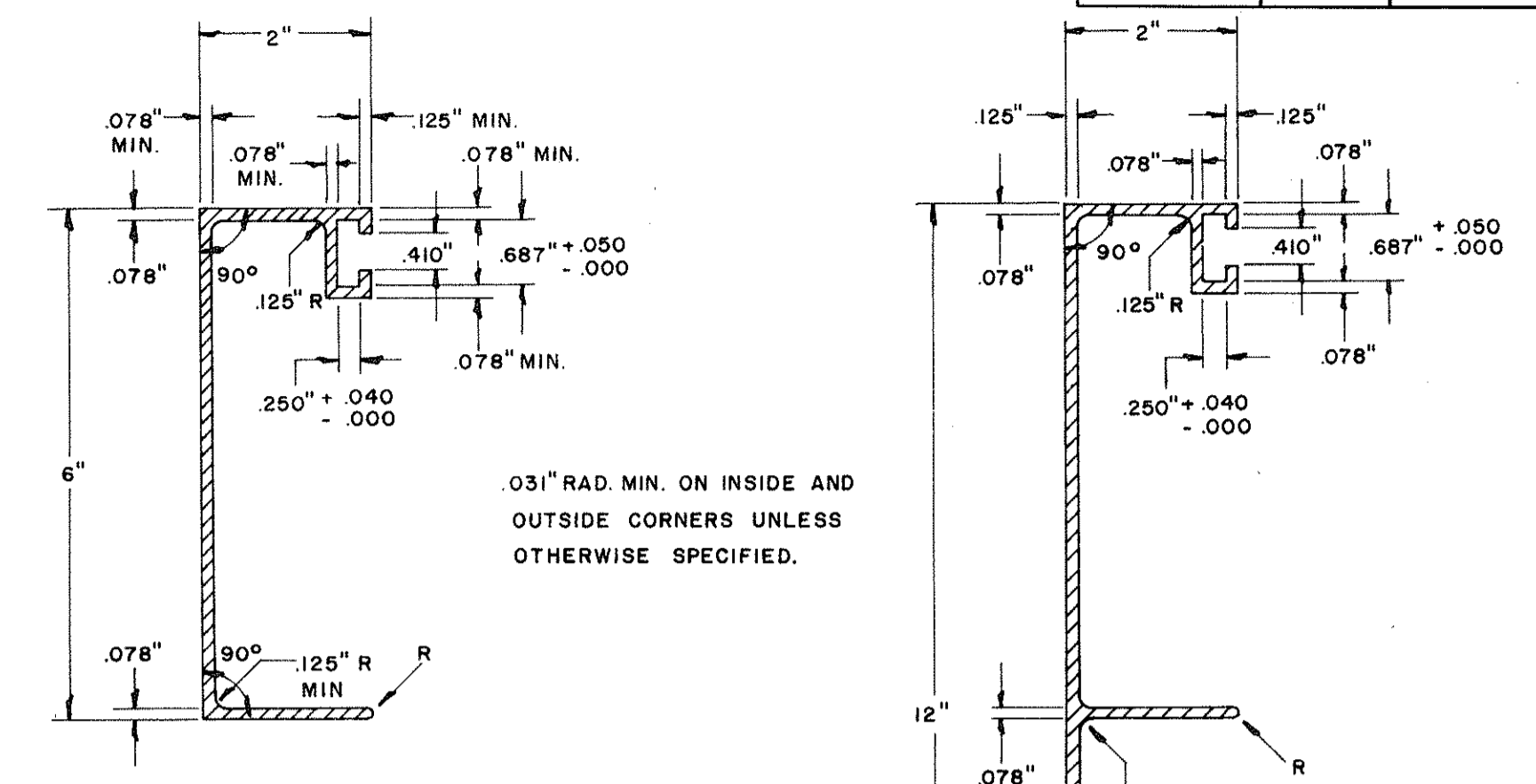
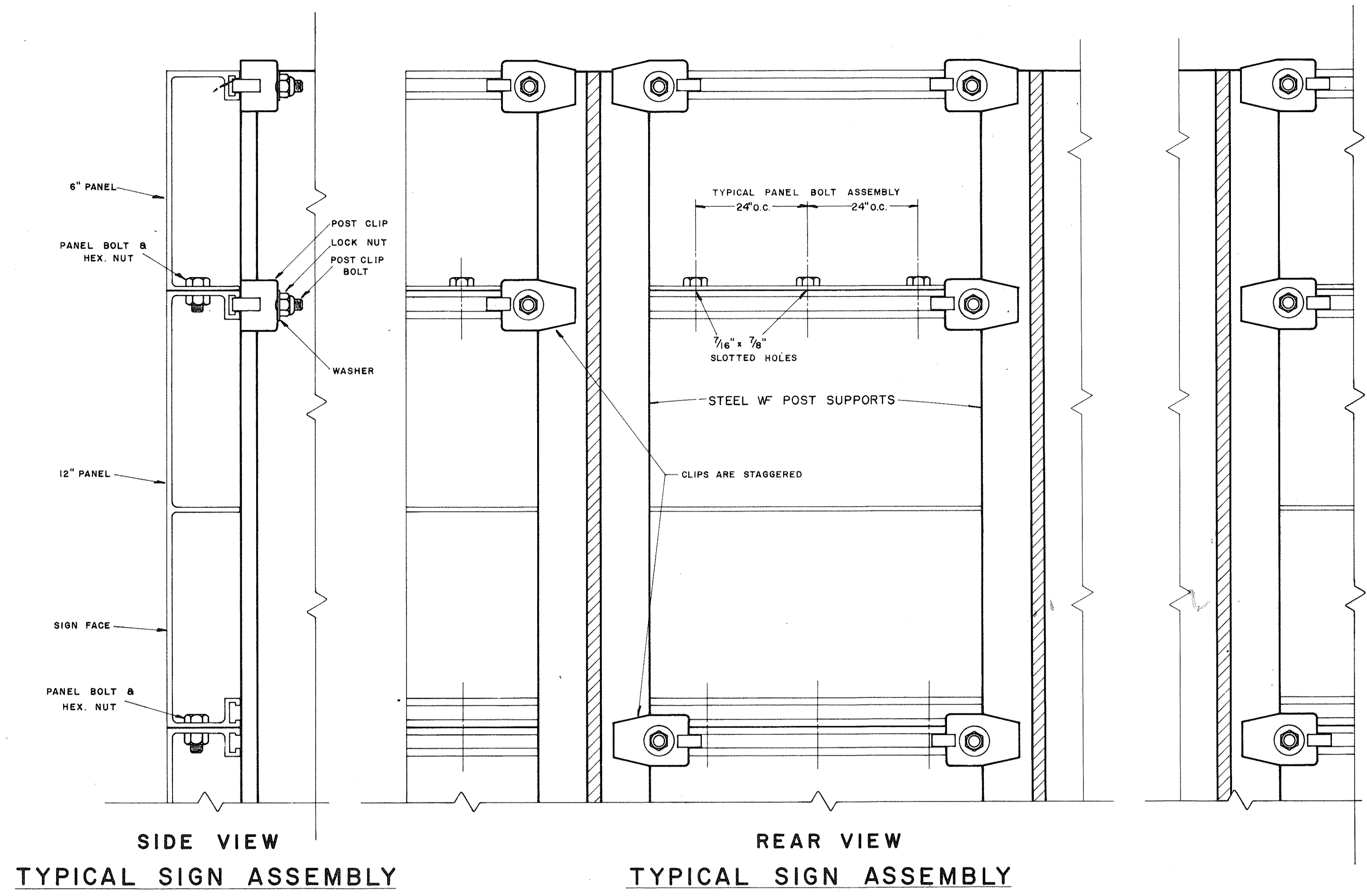

SOLID EXTRUDED SIGN PANEL DETAILS

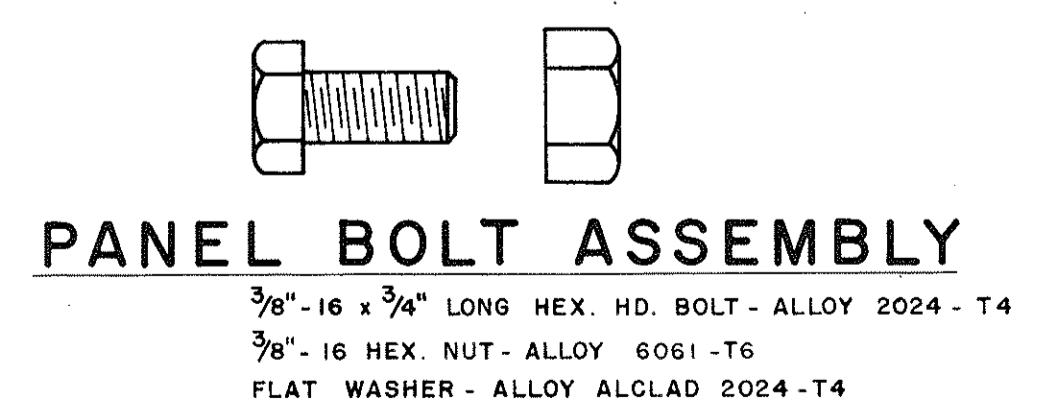
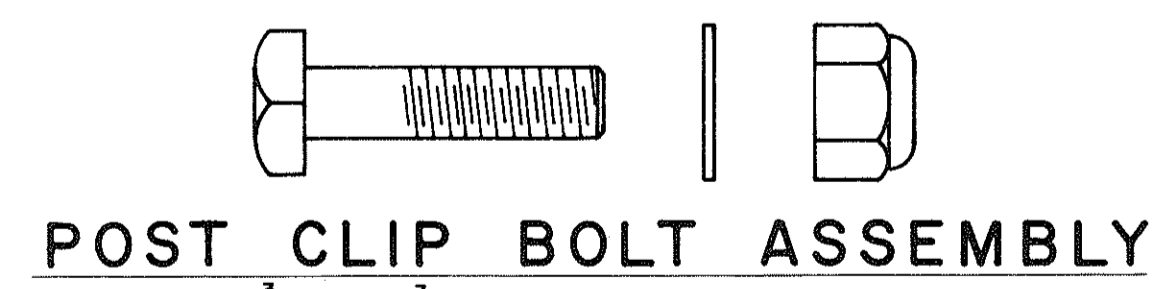
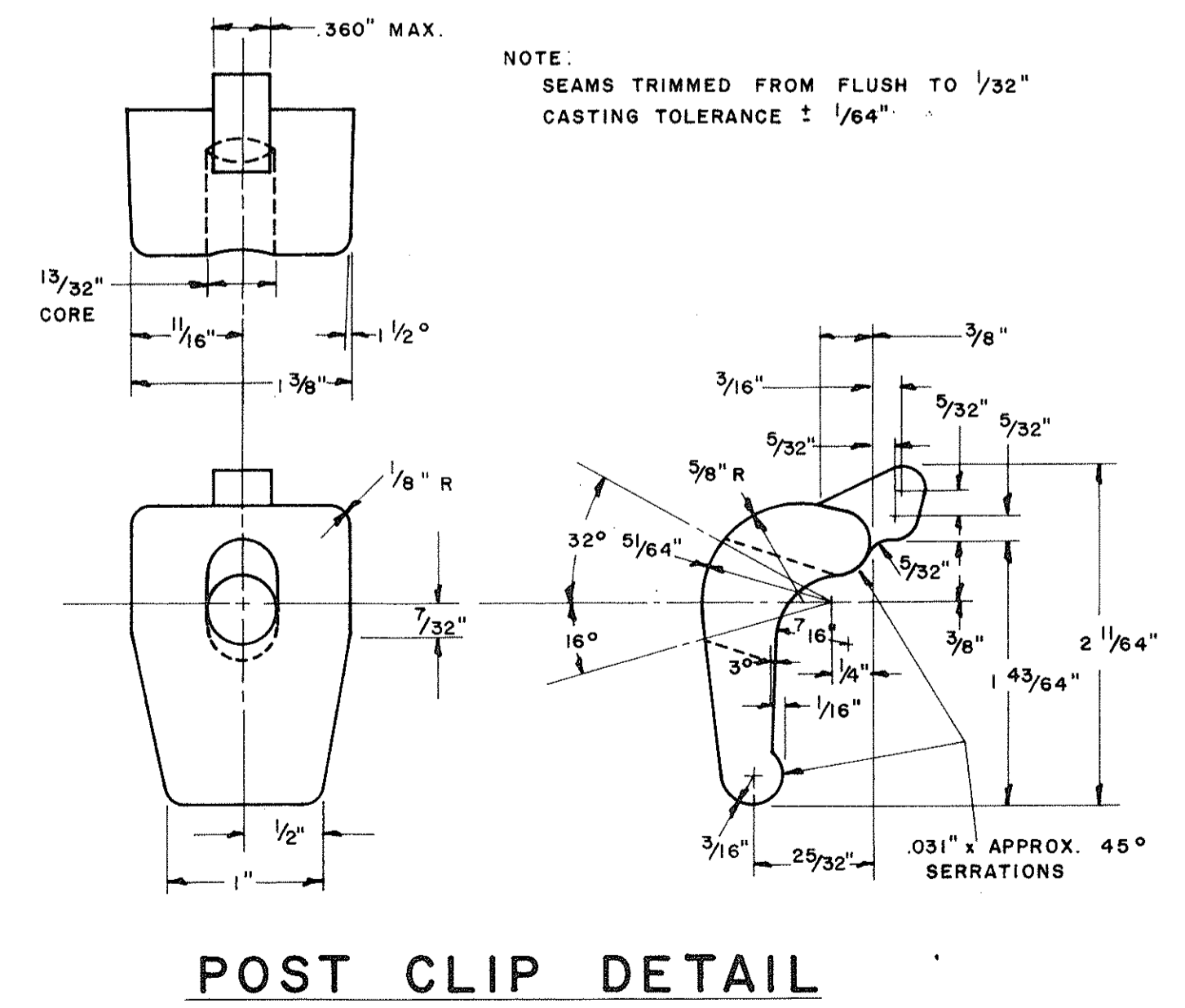

NOTE:
Extruded Aluminum Panels to be used for
Destination Signs with Reflective Sheeting Background

APPROVAL RECOMMENDED:
Euchi Tanaka 12/29/69
TRAFFIC ENGINEER DATE

APPROVED:
[Signature] 12-30-69
ASSISTANT CHIEF, ENGINEERING DATE

NO.	REVISION	APPROVED BY	DATE

STATE OF HAWAII
DEPARTMENT OF TRANSPORTATION
HIGHWAYS DIVISION
STANDARD DETAILS
SOLID ALUMINUM
EXTRUDED SIGN PANEL
AND
ACCESSORY DETAILS
SCALE:

SURVEY PLOTTED BY	DATE
DESIGNED BY	
TRACED BY	
QUANTITIES CHECKED BY	
NOTE BOOK CHECKED BY	
ORIGINAL PLAN No.	

FED. ROAD DIST. NO.	STATE	FED. AID PROJ. NO.	FISCAL YEAR	SHEET NO.	TOTAL SHEETS
HAWAII	HAW.	11-FE078-1(6)	1976	62	142

MARKER SIZE	MULTIPLY DIMENSIONS BY	NUMERAL SIZE
16"	1	6"
21"	1.3	8"
32"	2.0	12"
42"	2.63	16"

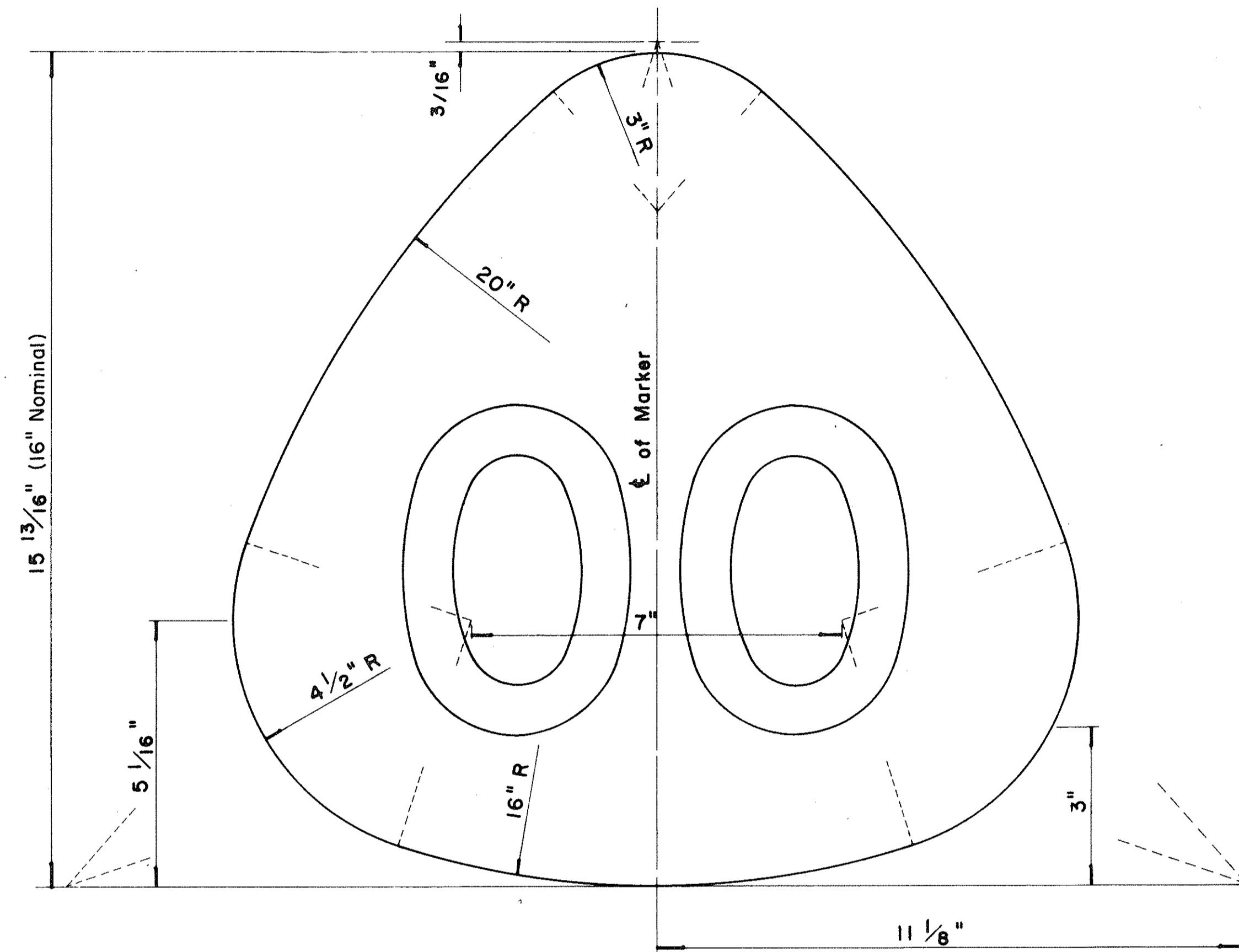

**STATE ROUTE MARKER
FOR GUIDE SIGNS**

Scale: Half Size

NOTE:

- State Route Markers on Guide signs shall have black numerals on a white reflectorized background mounted on a flat aluminum cut-out.
- Numerals shall conform to the FHWA publication "Standard Alphabets for Highway Signs," 1966.
- Cut-outs shall be fastened on sign panel with aluminum blind rivets. See Standard Specifications.
- * The 16" State Route Marker shall be used only with the Construction Identification sign.

RADII FOR SIGNS		
Least Dimension of Sign	W	R
2'-0" to 4'-6"	2"	3"
4'-9" to 5'-6"	2"	6"
5'-9" to 7'-6"	2"	9"
7'-9" and greater	2"	12"

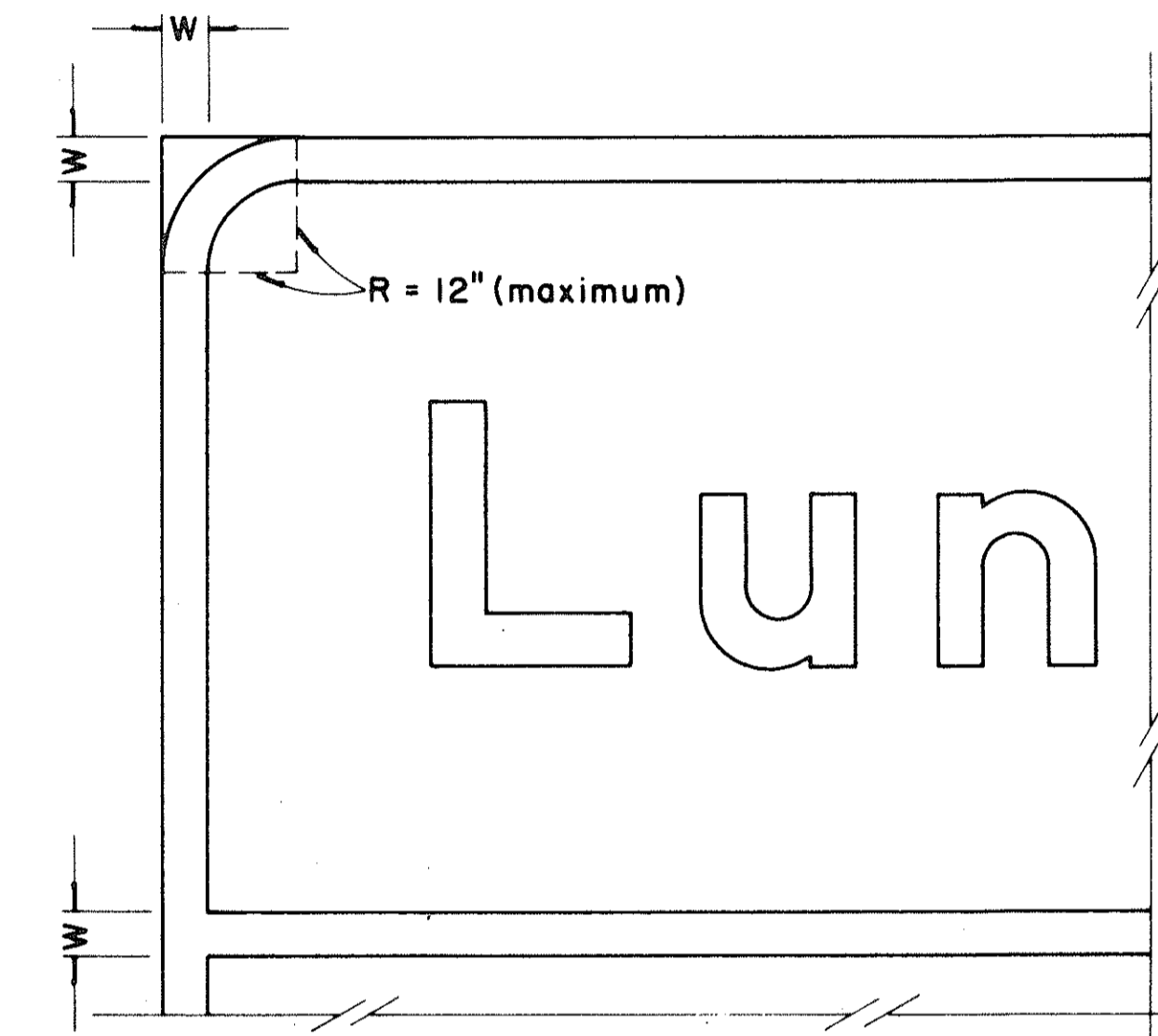

**BORDER DETAIL
FOR GUIDE SIGNS**

Not to Scale

NOTE:

- Area outside corner radius need not be trimmed.
- All borders shall be embossed cut-outs, white and reflectorized.
- All Guide signs shall have borders.

APPROVAL RECOMMENDED:

Eiichi Tanaka 4/11/72
TRAFFIC ENGINEER DATE

APPROVED:

Shelby S. Sakischi 4/12/72
ASSISTANT CHIEF, ENGINEERING DATE

NO.	REVISION	APPROVED BY	DATE
1	Supersedes Sht. DT 209 Approved 12-30-69	H.T.	4/12/72

STATE OF HAWAII
DEPARTMENT OF TRANSPORTATION
HIGHWAYS DIVISION

**STANDARD DETAILS
STATE ROUTE MARKER
AND BORDER DETAIL
FOR GUIDE SIGNS**

Scale: As Shown

SHEET No. 11 OF 13 SHEETS DT 209

DATE	_____
DESIGNED BY	_____
CHECKED BY	_____
NO. BOOK	_____
ORIGINAL PLAN	_____
DATE	_____
DESIGNED BY	_____
CHECKED BY	_____
NO.	_____

FED. ROAD DIST. NO.	STATE	FED. AID PROJ. NO.	FISCAL YEAR	SHEET NO.	TOTAL SHEETS
HAWAII	HAW.	11FF078-1(6)	1976	63	142

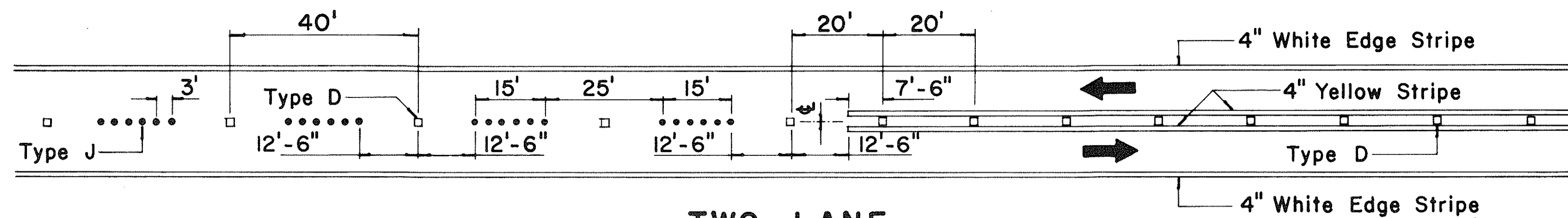

**TWO-LANE
PASSING PERMITTED AND PASSING PROHIBITED**

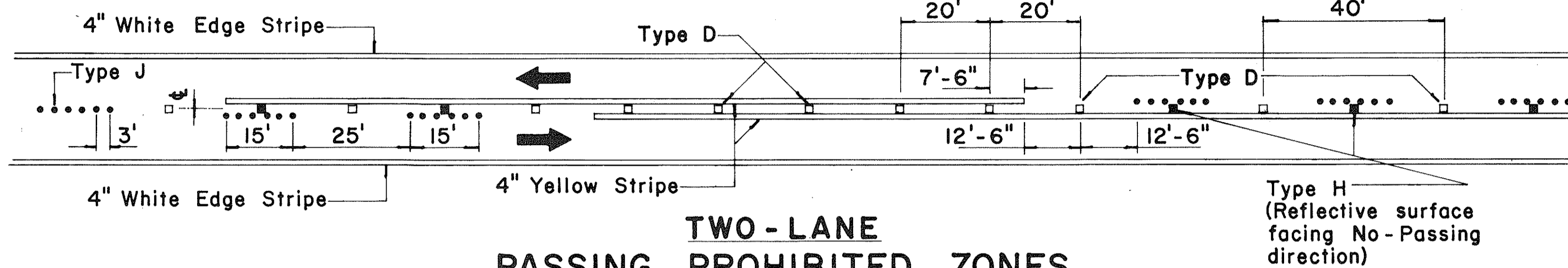

**TWO-LANE
PASSING PROHIBITED ZONES**

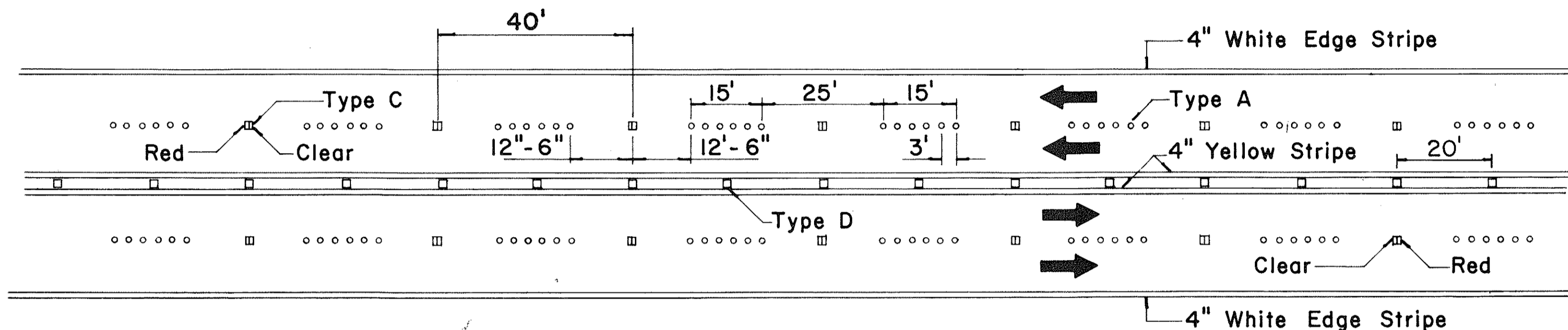

**MULTI-LANE
LANE LINES AND CENTER LINE**

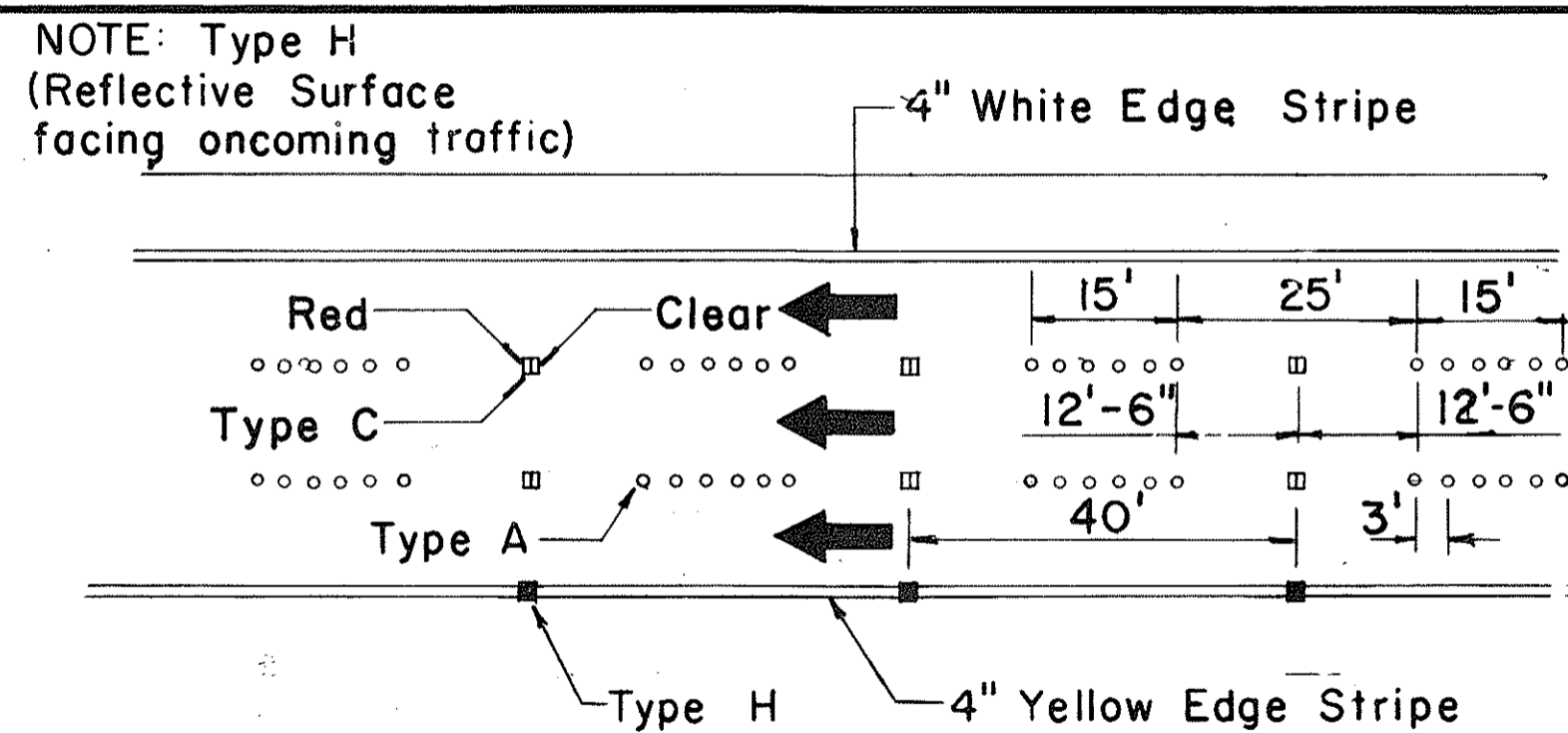

DIVIDED HIGHWAY LANE LINES

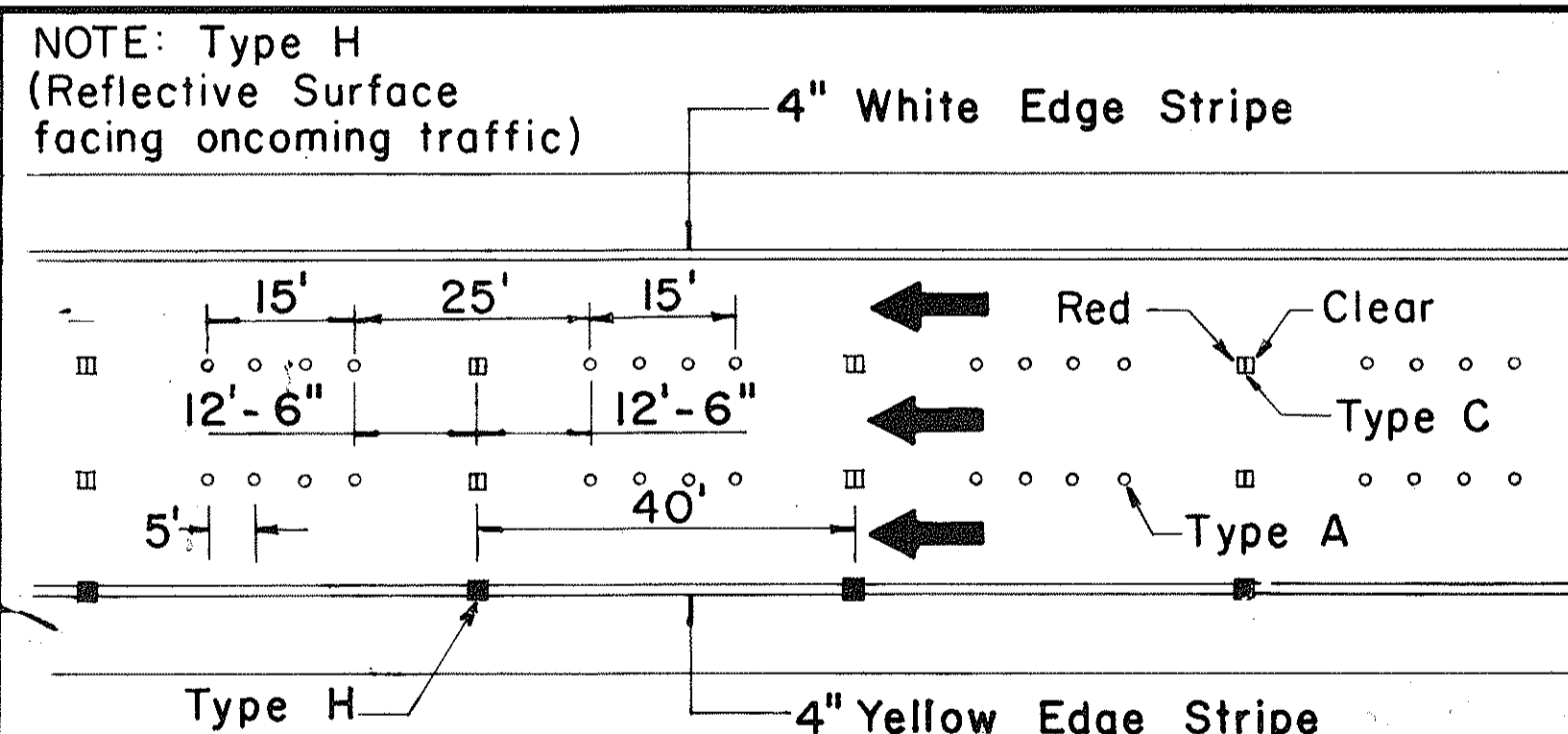

FREEWAY LANE LINES

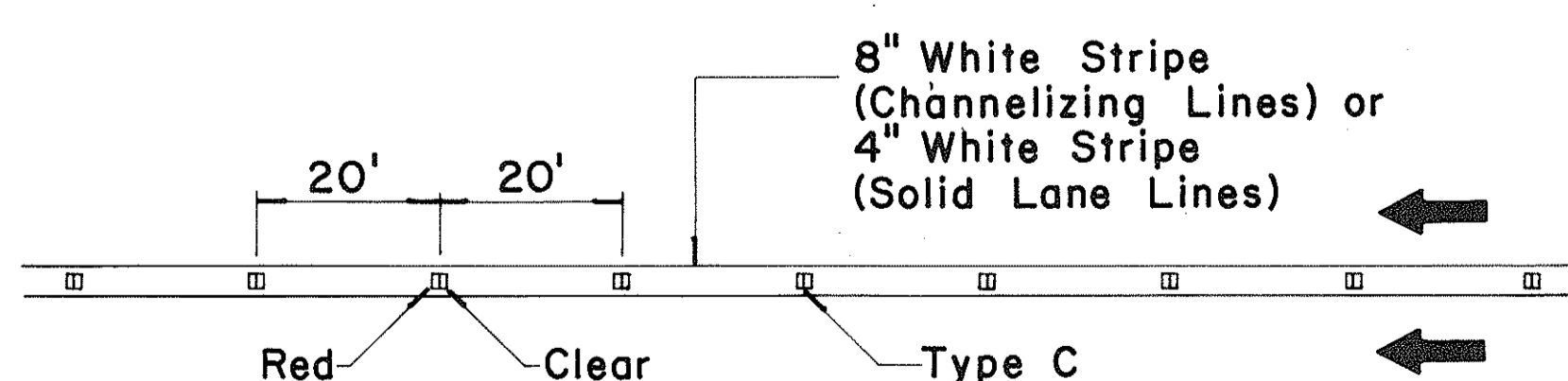

**CHANNELIZING LINES
OR SOLID LANE LINES**

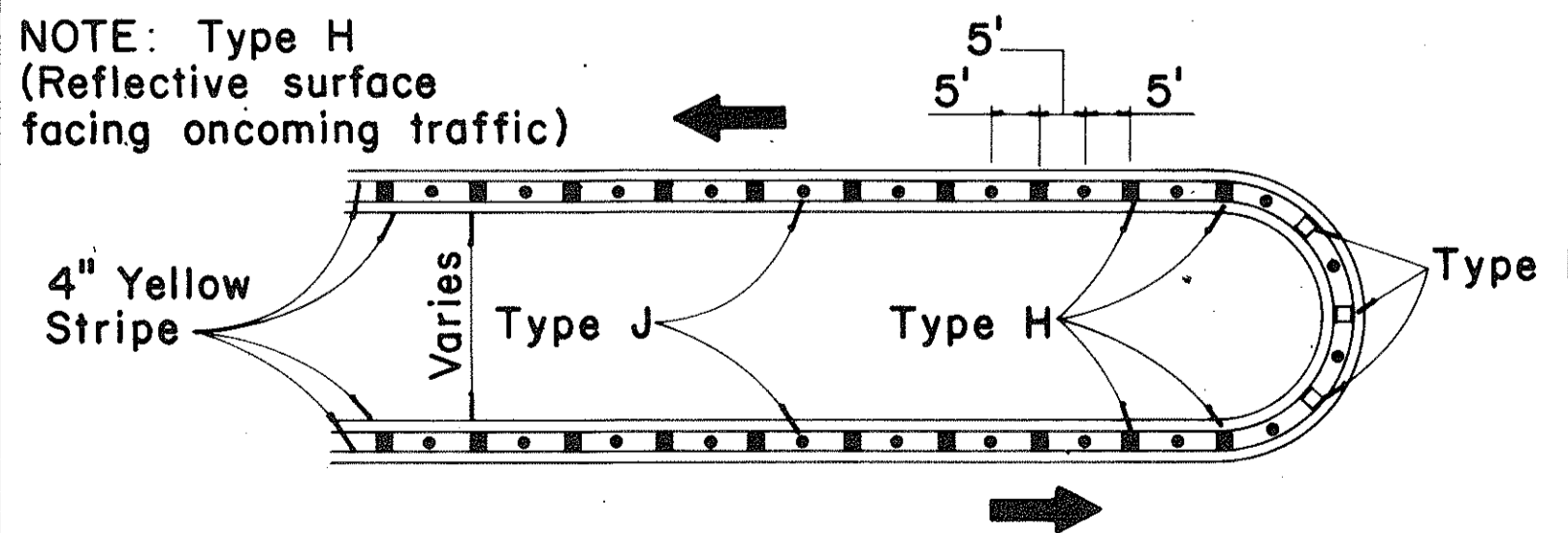

MEDIAN NOSE DELINEATION

TWO - LANE

MULTI - LANE

DIVIDED HIGHWAY
AND
FREEWAY

MISCELLANEOUS

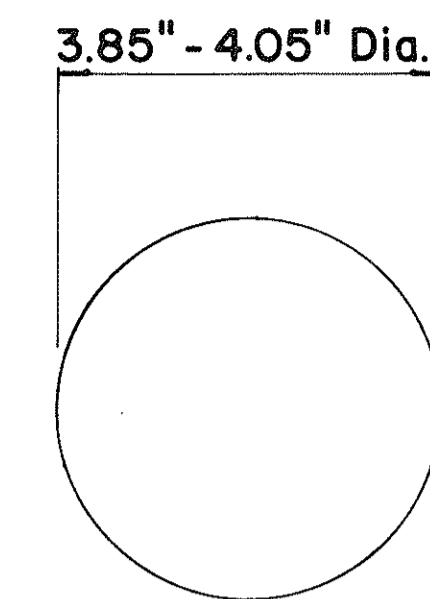

**TYPE A
NON-REFLECTIVE WHITE MARKER**

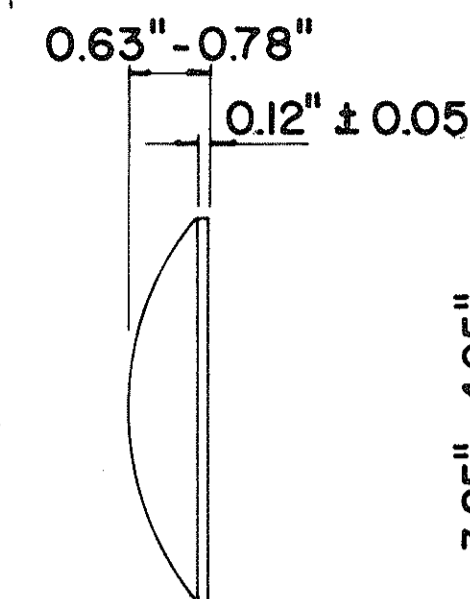

**TYPE J
NON-REFLECTIVE YELLOW MARKER**

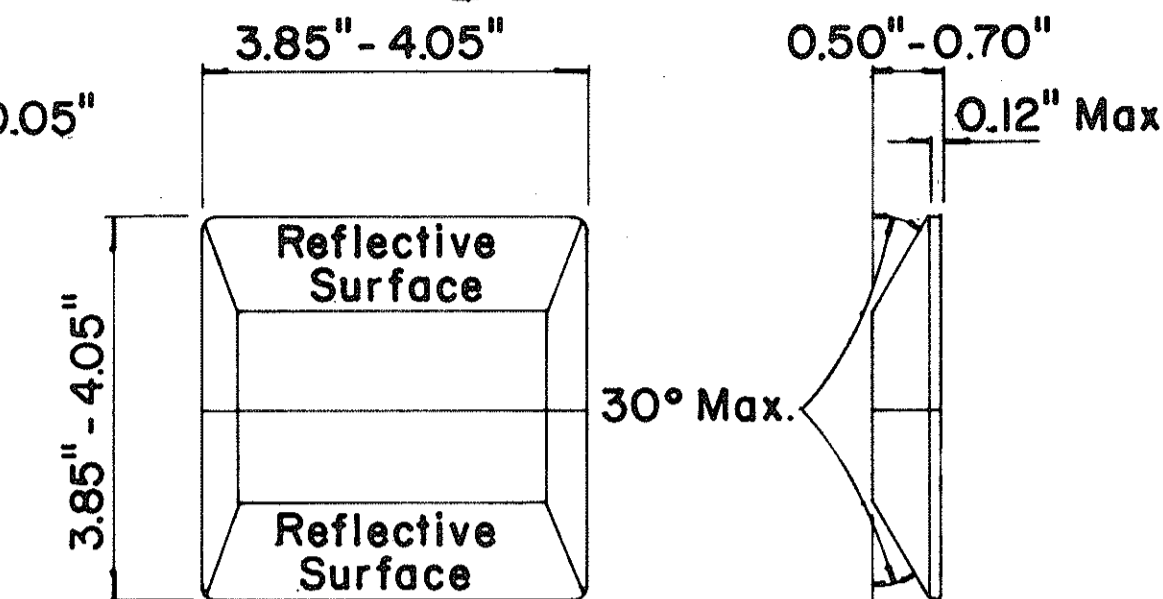

**TYPE C
RED-CLEAR REFLECTIVE MARKER**

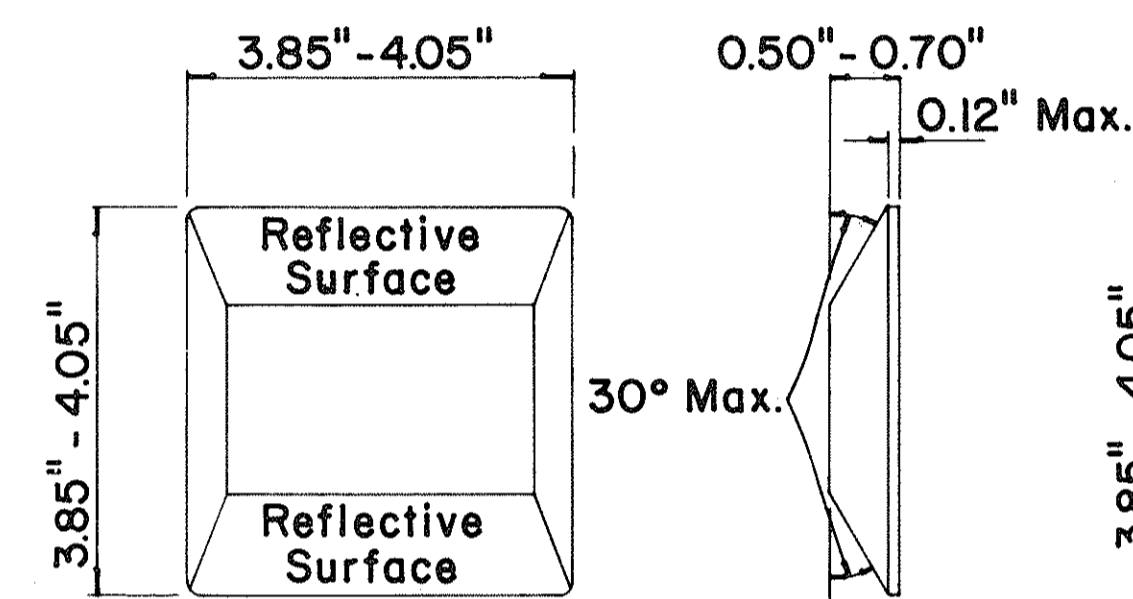

**TYPE D
TWO-WAY YELLOW REFLECTIVE MARKER**

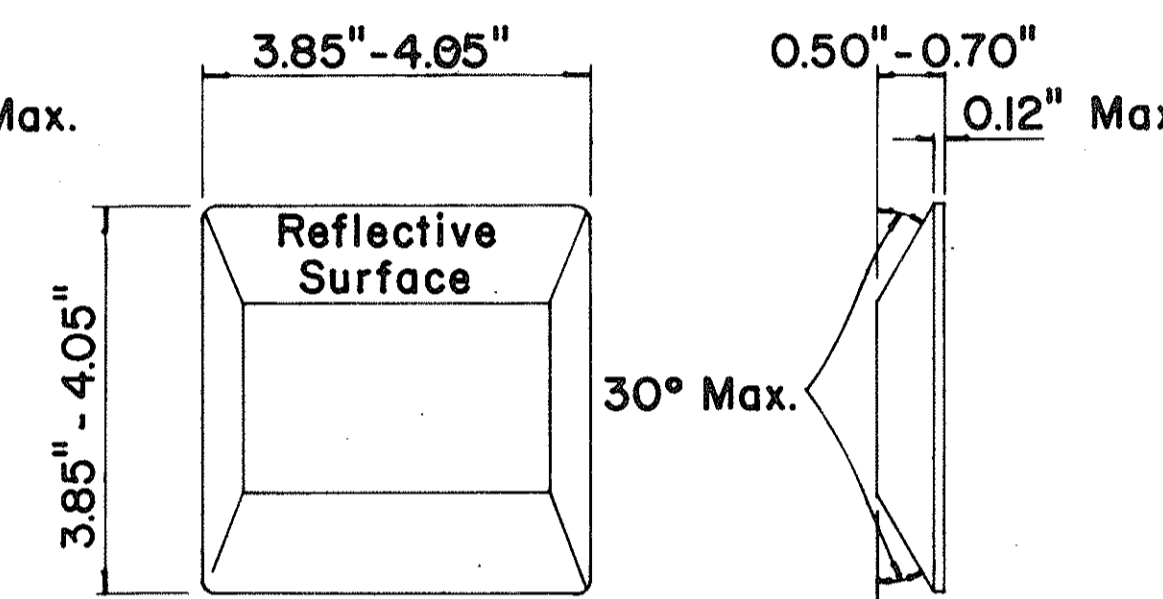

**TYPE H
ONE-WAY YELLOW REFLECTIVE MARKER**

GENERAL NOTES

1. Painted stripes to be done by Contractor unless otherwise specified.

LEGEND

- Type A
- Type C
- Type D
- Type H
- Type J

APPROVAL RECOMMENDED:
Eiichi Tanaka 11/18/71
TRAFFIC ENGINEER DATE

APPROVED:
Shelton S. Sato 11/18/71
ASSISTANT CHIEF, ENGINEERING DATE

No.	REVISION	APPROVED BY	DATE
1	Add reflector marker in each line gap.	H.C.	10-21-72
2	Revised General Notes.	H.C.	10-27-72
3	Change 4" white edge stripe to 4" solid yellow edge stripe to left edge of a travel path and Add Type H Reflector Marker	H.C.	5-22-74

STATE OF HAWAII
DEPARTMENT OF TRANSPORTATION
HIGHWAYS DIVISION
STANDARD DETAILS
RAISED PAVEMENT MARKERS

Not to Scale October 1971
SHEET No. 12 OF 13 SHEETS DT 300

DATE: _____
SURVEY PLOTTED BY: _____
DRAWN BY: _____
CHECKED BY: _____
NOTE BOOK No. _____

FED. ROAD DIST. NO.	STATE	FED. AID PROJ. NO.	FISCAL YEAR	SHEET NO.	TOTAL SHEETS
HAWAII	HAW.	U-FF-078-1(6)	1976	64	142

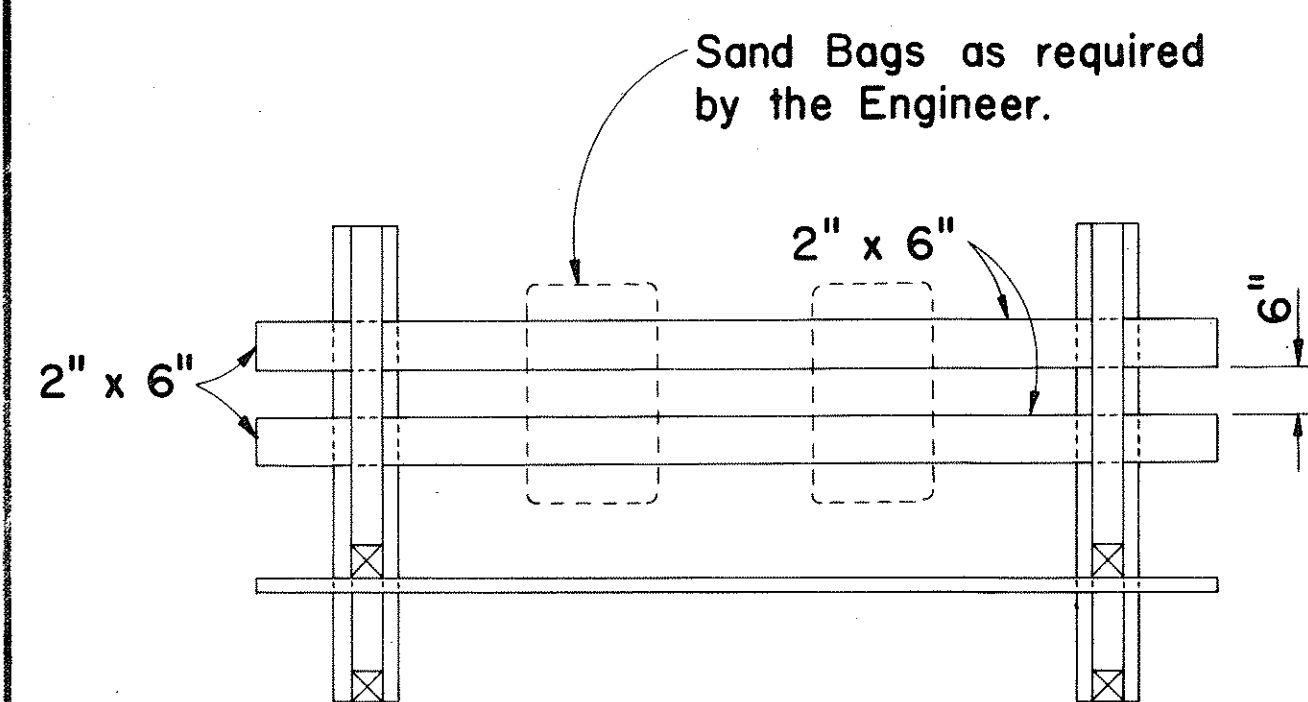

PLAN VIEW

GENERAL NOTES

1. The Contractor shall construct, install and maintain the wood barricades at the locations shown on the Plans.
2. The permanent wood barricades shall be left in place or relocated upon completion of the project as ordered by the Engineer and are to become State property.
3. The orange and white stripes shall slant downward toward the side on which traffic is to pass and shall be reflectorized with high intensity reflective sheeting.

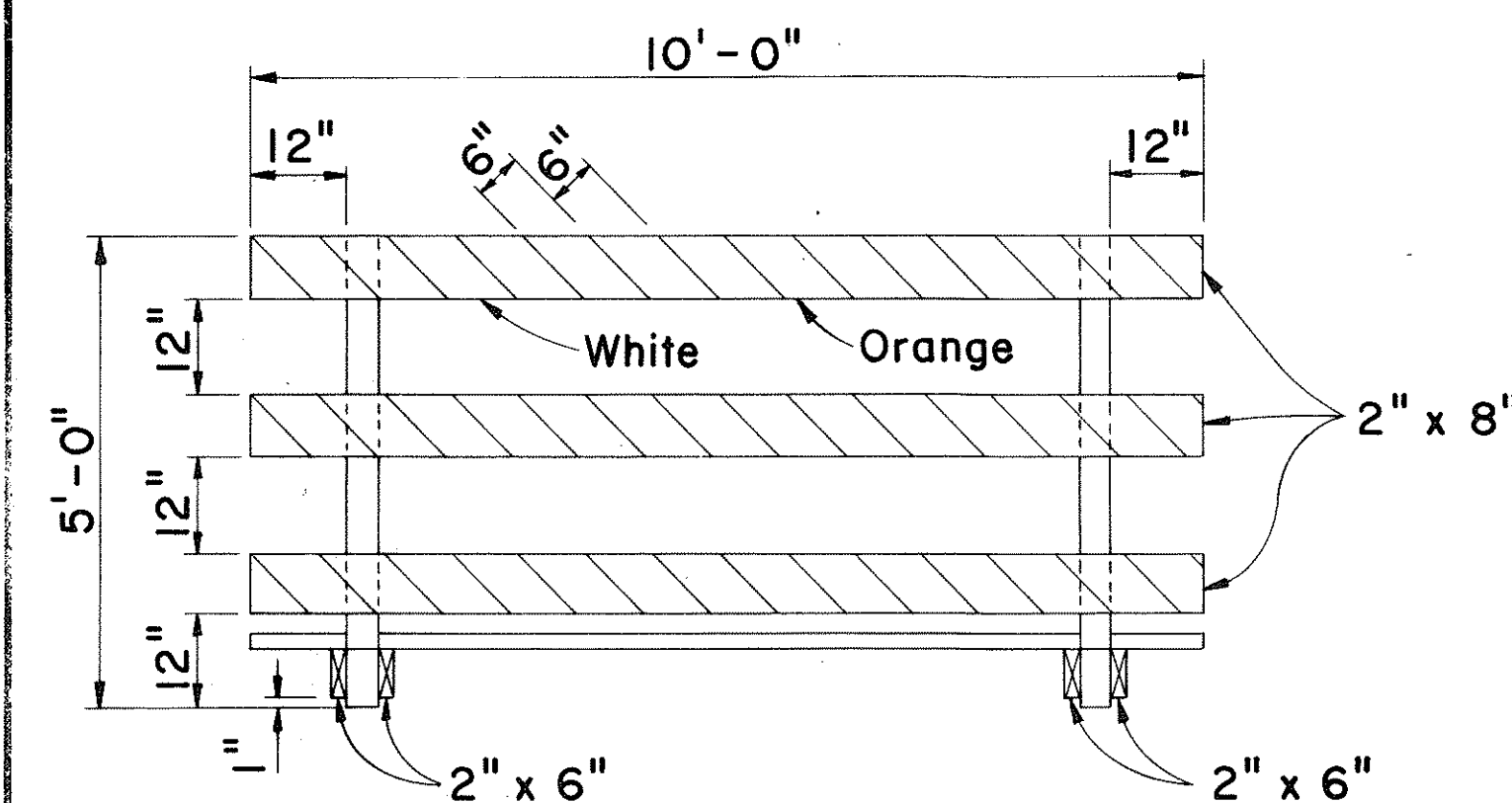

FRONT VIEW

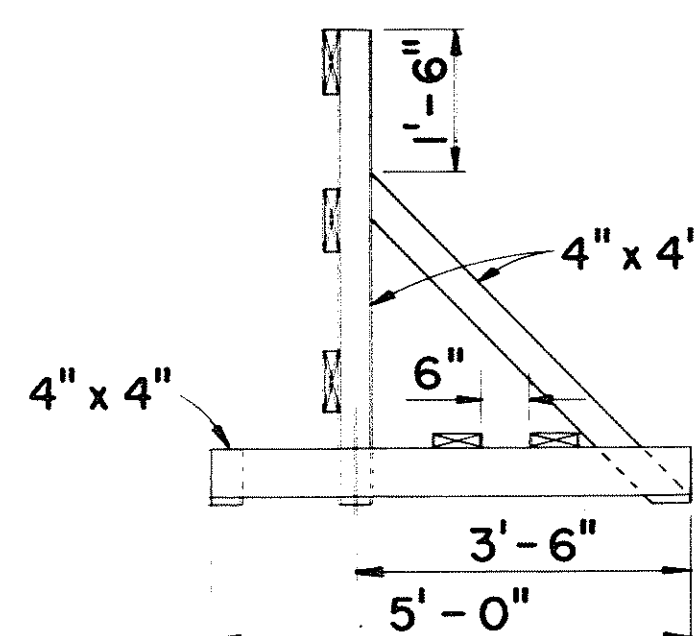

END VIEW

CLASS I BARRICADE

Scale: 1/2" = 1'-0"

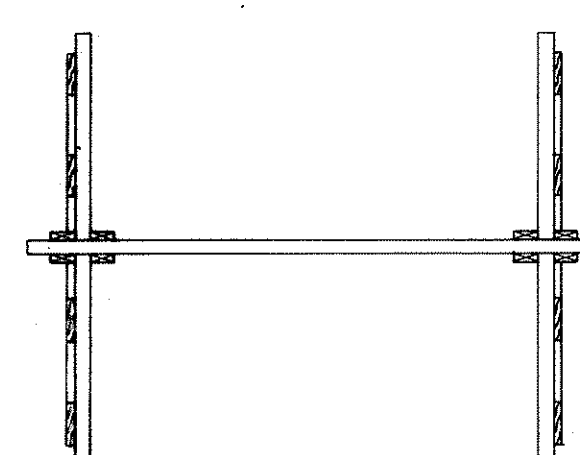

PLAN VIEW

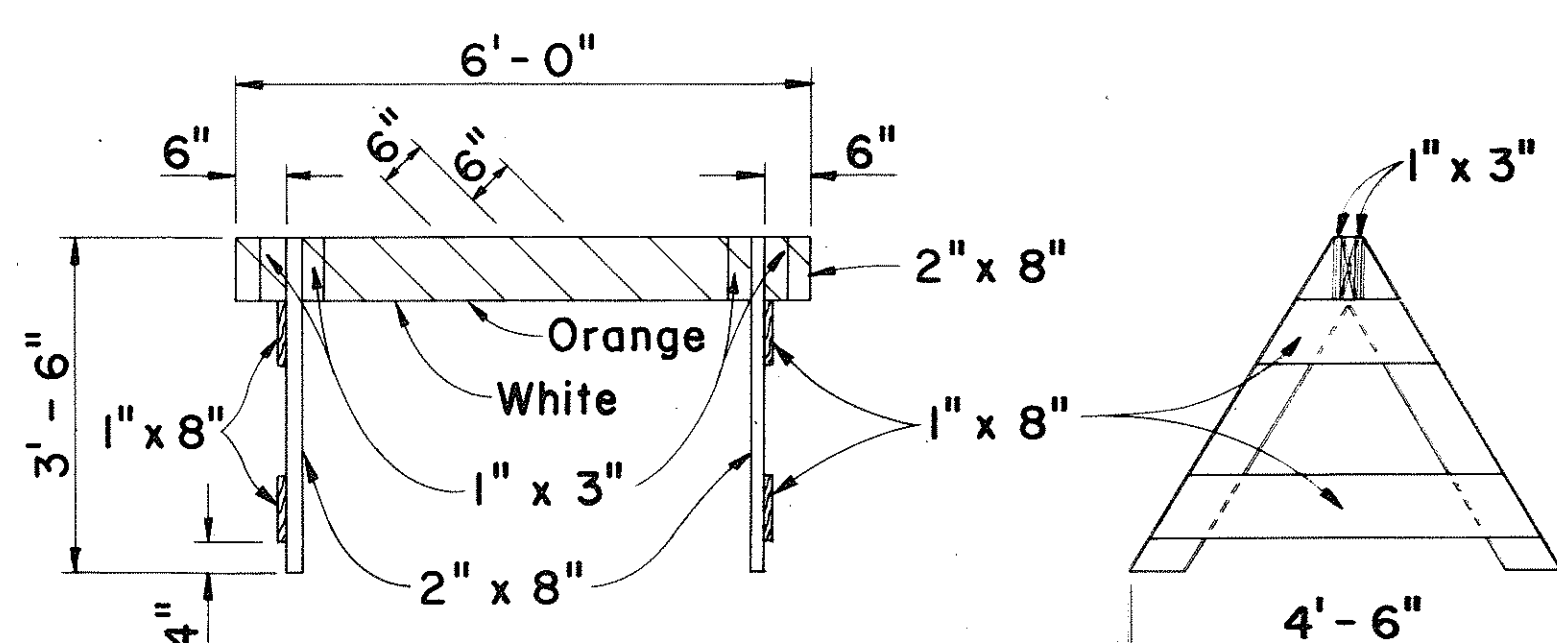

FRONT VIEW

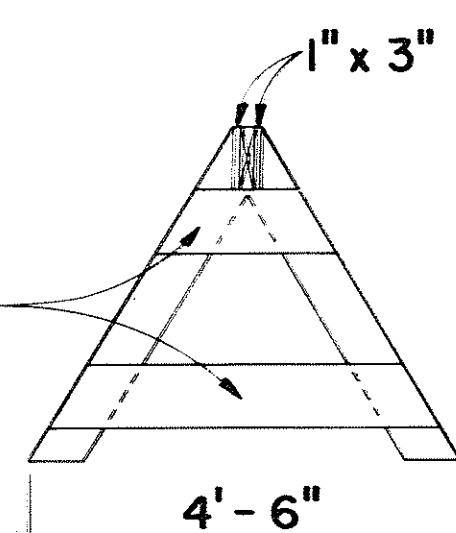

END VIEW

CLASS II BARRICADE

Scale: 1/2" = 1'-0"

APPROVAL RECOMMENDED:

Eiichi Tanaka 12/29/69
TRAFFIC ENGINEER DATE

APPROVED:

Andrew S. Sato 12-30-69
ASSISTANT CHIEF, ENGINEERING DATE

NO.	REVISION	APPROVED BY	DATE
1	Reduce sign width to 12'-0"	H.T.	9-3-10
2	Delete "Bureau of Public Roads"	H.T.	9-29-10
3	Add Note No. 3 for Barricades	H.T.	5-4-11
4	Revise stripe color for Barricades	H.T.	10-21-12

NO.	REVISION	APPROVED BY	DATE
5	Revise General Note 3 for Barricades. Delete details of Construction Identification Sign.	H.T.	9-16-75

STATE OF HAWAII
DEPARTMENT OF TRANSPORTATION
HIGHWAYS DIVISION

TYPICAL DETAILS
CONSTRUCTION IDENTIFICATION SIGN
AND
WOOD BARRICADES

SCALE: As Shown DATE:

ORIGINAL PLAN
DRAWN BY
DESIGNED BY
CHECKED BY
DATE