

FED. ROAD DIST. NO.	STATE	FED. AID PROJ. NO.	FISCAL YEAR	SHEET NO.	TOTAL SHEETS
HAWAII	HAW.	I-HI-1(147):17	1981	34	159

NOTES:  
 1. FOR LEGEND SEE SHEET NO. P-1  
 2. FOR GENERAL NOTES SEE SHEET NO. P-2

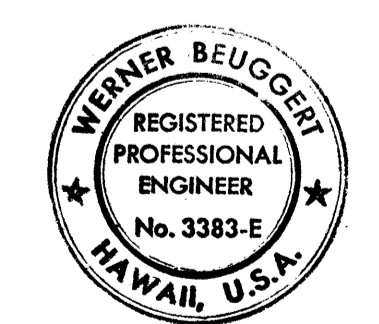
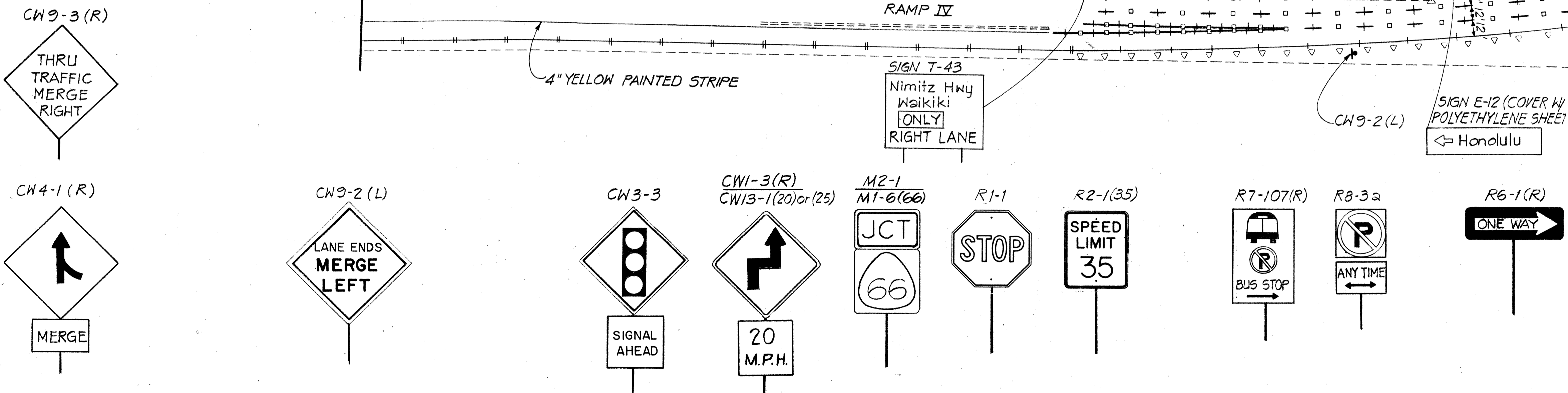
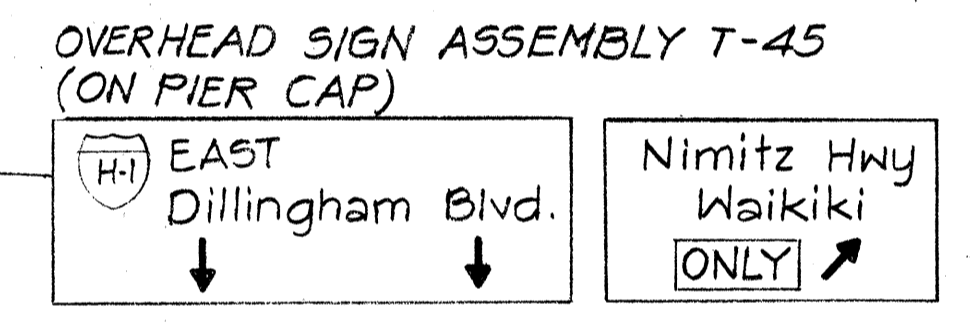
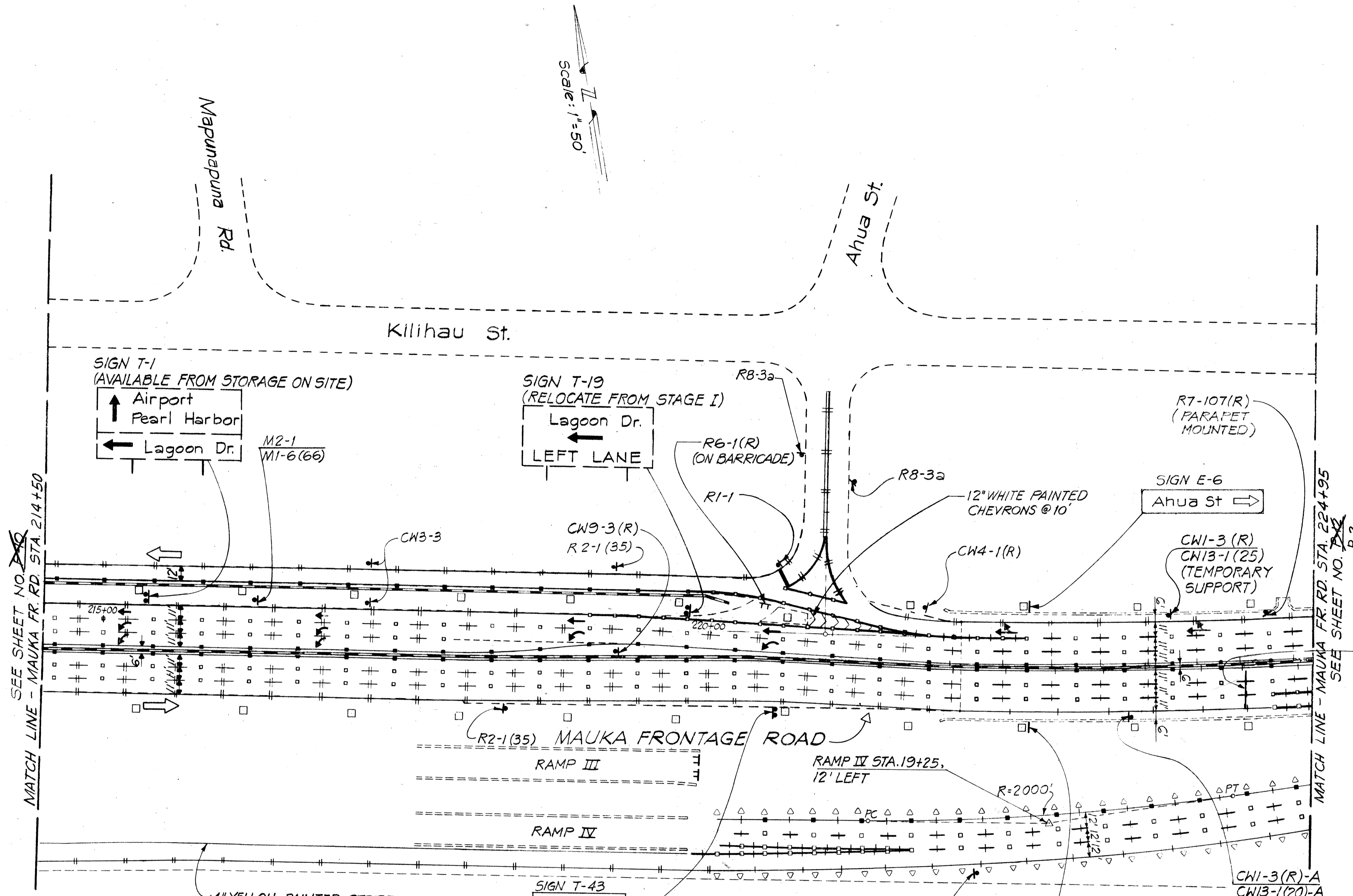

THIS WORK WAS PREPARED BY ME OR UNDER MY SUPERVISION.  
 Werner Beugert

FOR INFORMATION ONLY, NOT FOR CONSTRUCTION  
 STATE OF HAWAII  
 DEPARTMENT OF TRANSPORTATION  
 HIGHWAYS DIVISION  
 TRAFFIC PATTERN (A)  
 SIGNING & PAVEMENT MARKINGS  
 CONSTRUCTED IN  
 INTERSTATE ROUTE H-1  
 PROJECT NO. I-HI-1 (147):17  
 SCALE: 1" = 50' DATE: 4/2/79  
 SHEET NO. P-1 OF P-17 SHEETS

FED. ROAD DIST. NO.	STATE	FED. AID PROJ. NO.	FISCAL YEAR	SHEET NO.	TOTAL SHEETS
HAWAII	HAW.	I-HI-1(133)17	1981	35	159

NOTES:  
 1. FOR LEGEND SEE SHEET NO. P-2  
 2. FOR GENERAL NOTES SEE SHEET NO. P-3

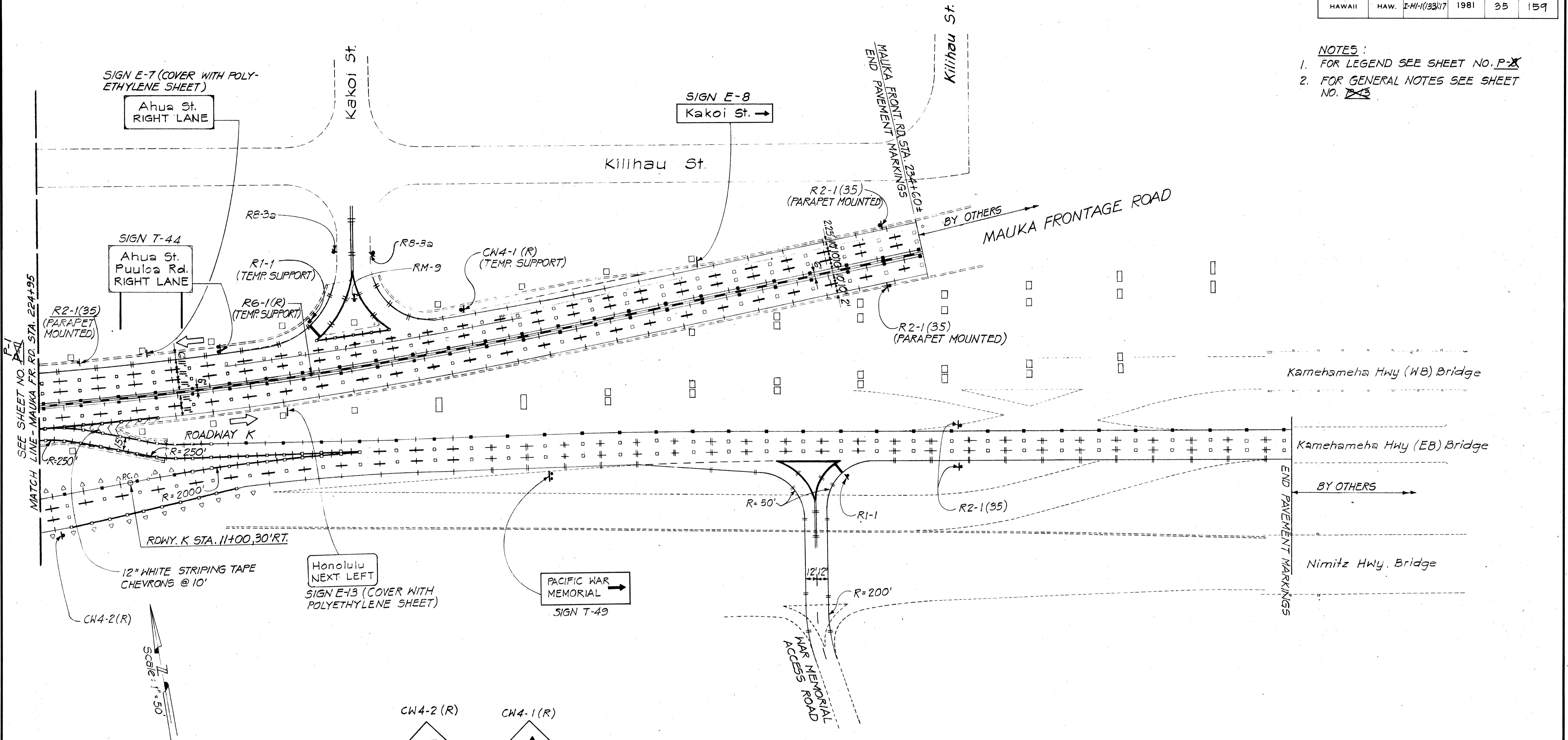

SEE SHEET NO. P-1  
 MATCH LINE - MAUKA FR. RD. STA. 224+95

SIGN E-7 (COVER WITH POLY-ETHYLENE SHEET)

Ahua St. RIGHT LANE

SIGN E-8  
 Kakoi St. →

SIGN T-44

Ahua St. Puuloa Rd. RIGHT LANE

12" WHITE STRIPING TAPE CHEVRONS @ 10'

Honolulu NEXT LEFT  
 SIGN E-13 (COVER WITH POLYETHYLENE SHEET)

PACIFIC WAR MEMORIAL  
 SIGN T-49

Kamehameha Hwy (WB) Bridge

Kamehameha Hwy (EB) Bridge

Nimitz Hwy. Bridge

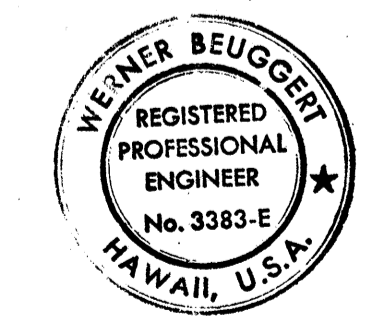
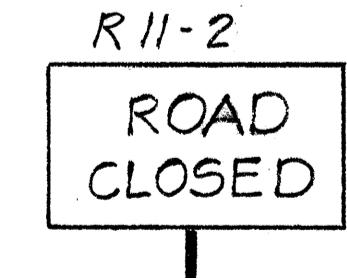
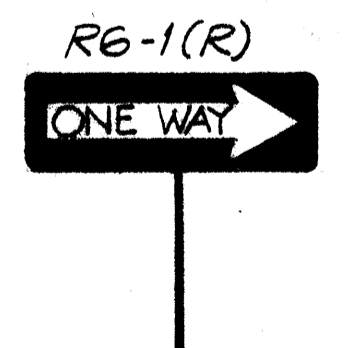
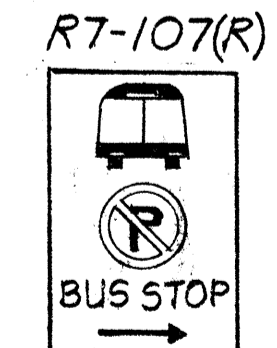
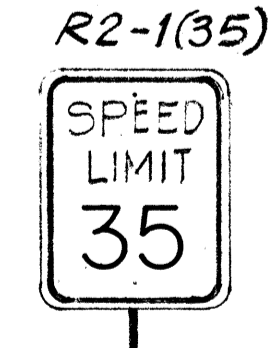
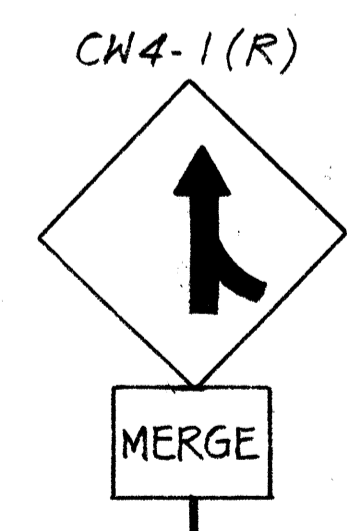
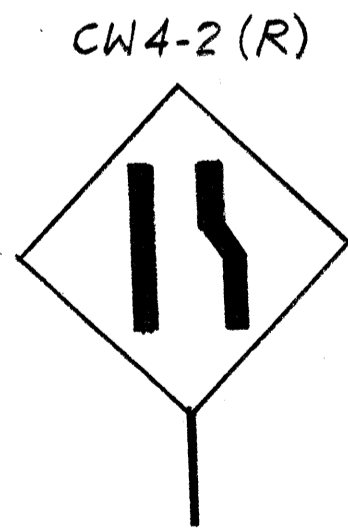

THIS WORK WAS PREPARED BY ME OR UNDER MY SUPERVISION.  
 Werner Beugert

FOR INFORMATION ONLY, NOT FOR CONSTRUCTION

STATE OF HAWAII  
 DEPARTMENT OF TRANSPORTATION  
 HIGHWAYS DIVISION

TRAFFIC PATTERN (A)  
**SIGNING & PAVEMENT MARKINGS**  
 CONSTRUCTED IN

INTERSTATE ROUTE H-1  
 PROJECT NO. I-HI-1 (147) :17

SCALE: 1" = 50' DATE: 4/2/79  
 SHEET No. P-2 OF P-17 SHEETS

DATE	
SURVEY PLOTTED BY	
DRAWN BY	
DESIGNED BY	
QUANTITIES BY	
NOTE BOOK	
CHECKED BY	
NO.	

FED. ROAD DIST. NO.	STATE	FED. AID PROJ. NO.	FISCAL YEAR	SHEET NO.	TOTAL SHEETS
HAWAII	HAW.	I-HI-1(131)17	1981	36	159

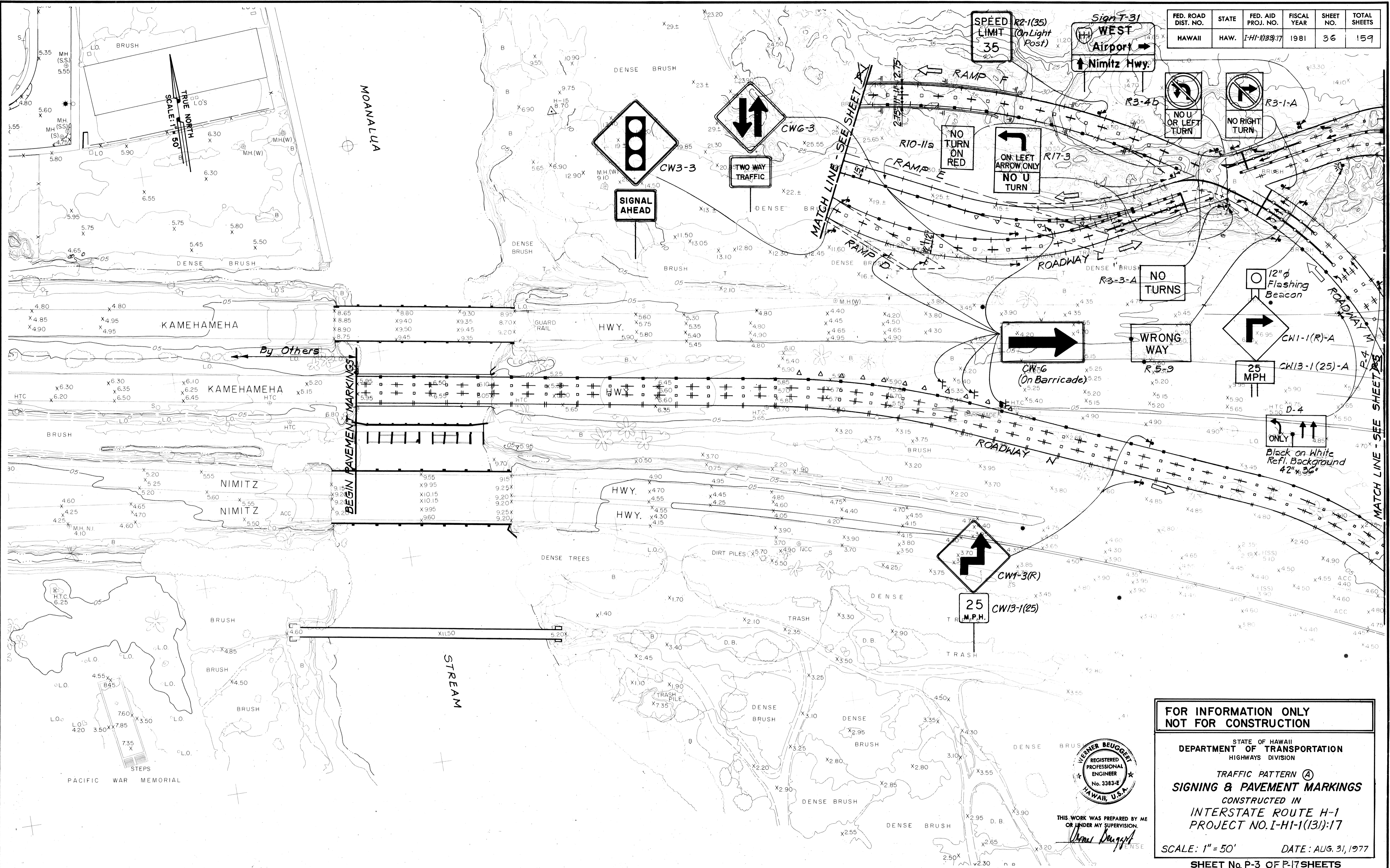

DATE	_____
SURVEY PLOTTED BY	_____
DRAWN BY	_____
DESIGNED BY	_____
QUANTITIES BY	_____
CHECKED BY	_____
ORIGINAL PLAN	_____
NOTE BOOK	_____
NO.	_____

**FOR INFORMATION ONLY  
NOT FOR CONSTRUCTION**

STATE OF HAWAII  
DEPARTMENT OF TRANSPORTATION  
HIGHWAYS DIVISION

TRAFFIC PATTERN (A)  
**SIGNING & PAVEMENT MARKINGS**  
CONSTRUCTED IN  
INTERSTATE ROUTE H-1  
PROJECT NO. I-HI-1(131):17

SCALE: 1" = 50'      DATE: AUG. 31, 1977

SHEET No. P-3 OF P-17 SHEETS

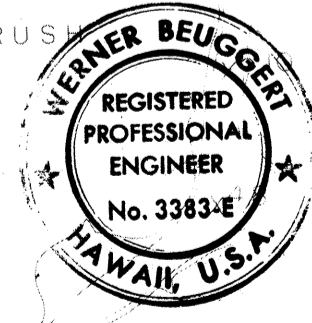

THIS WORK WAS PREPARED BY ME  
OR UNDER MY SUPERVISION.  
*Werner Beuggett*

FED. ROAD DIST. NO.	STATE	FED. AID PROJ. NO.	FISCAL YEAR	SHEET NO.	TOTAL SHEETS
HAWAII	HAW.	I-HI-1(13):17	1981	37	159

TRUE NORTH  
SCALE: 1" = 50'

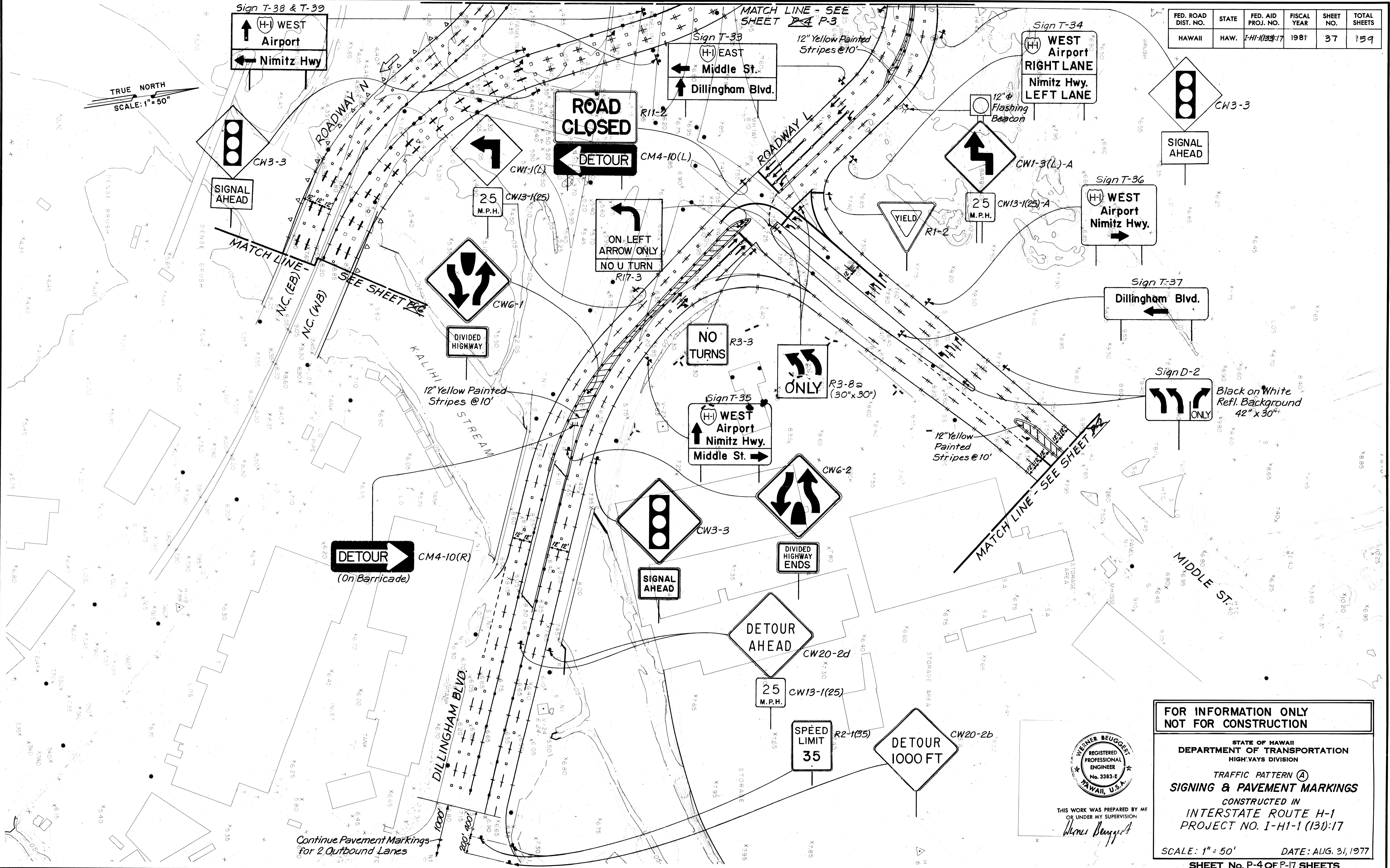

SURVEY PLOTTED BY	DATE
DESIGNED BY	
TRACED BY	
QUANTITIES BY	
CHECKED BY	
ORIGINAL PLAN	
NOTE BOOK	
NO.	

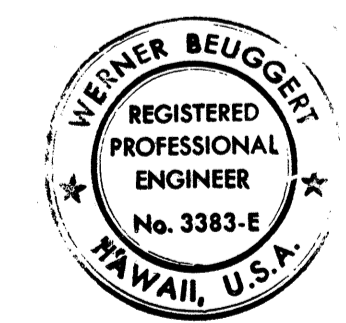

THIS WORK WAS PREPARED BY ME  
OR UNDER MY SUPERVISION  
*Werner Beugger*

**FOR INFORMATION ONLY  
NOT FOR CONSTRUCTION**

STATE OF HAWAII  
DEPARTMENT OF TRANSPORTATION  
HIGHWAYS DIVISION

TRAFFIC PATTERN (A)  
**SIGNING & PAVEMENT MARKINGS**  
CONSTRUCTED IN  
INTERSTATE ROUTE H-1  
PROJECT NO. I-HI-1 (13):17

SCALE: 1" = 50' DATE: AUG. 31, 1977  
SHEET No. P-4 OF P-17 SHEETS

FED. ROAD DIST. NO.	STATE	FED. AID PROJ. NO.	FISCAL YEAR	SHEET NO.	TOTAL SHEETS
HAWAII	HAW.	I-HH(133)17	1981	38	159

**NOTES:**

1. For General Notes see Sheet No. P-6.
2. Type of Sign Mounting for Temporary Destination Signs will be at the Contractor's Option, subject to approval by the Engineer.
3. Material used for Temporary Sign Panel and Overlay Panel ("T" Designation) shall be 3/4" thick, waterproof, Fir Plywood. Contractor may submit alternative, subject to approval by the Engineer.

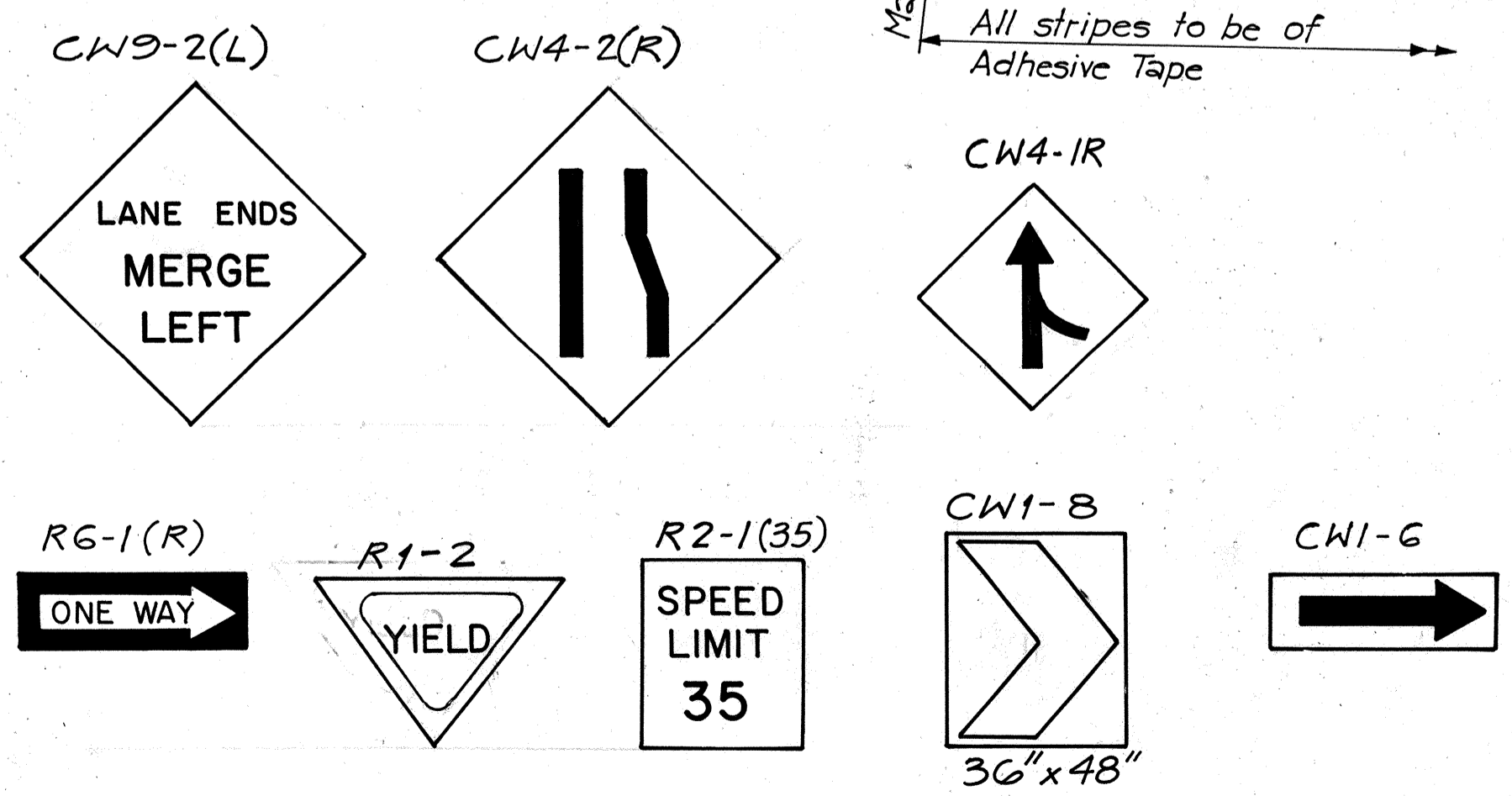
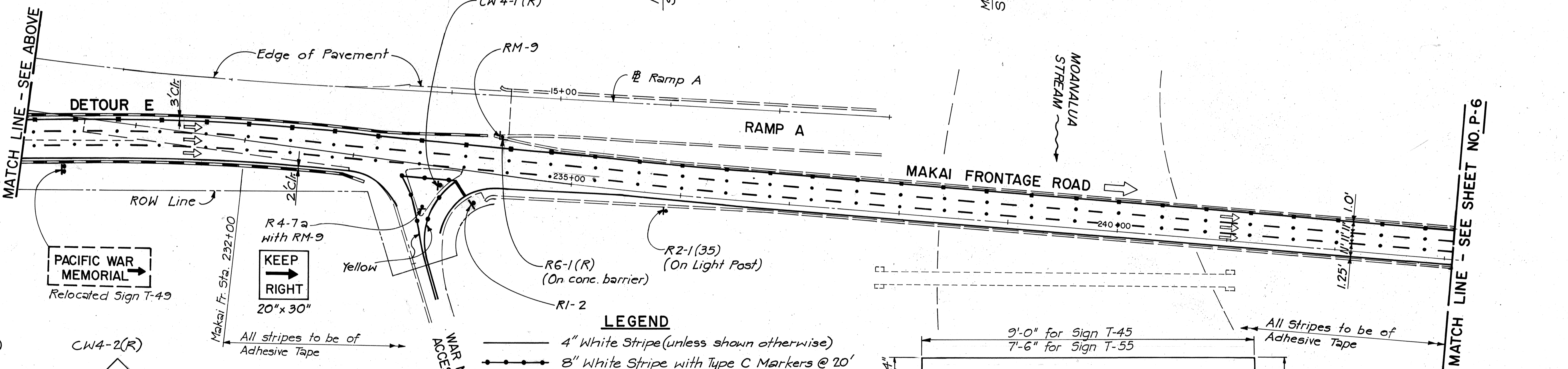
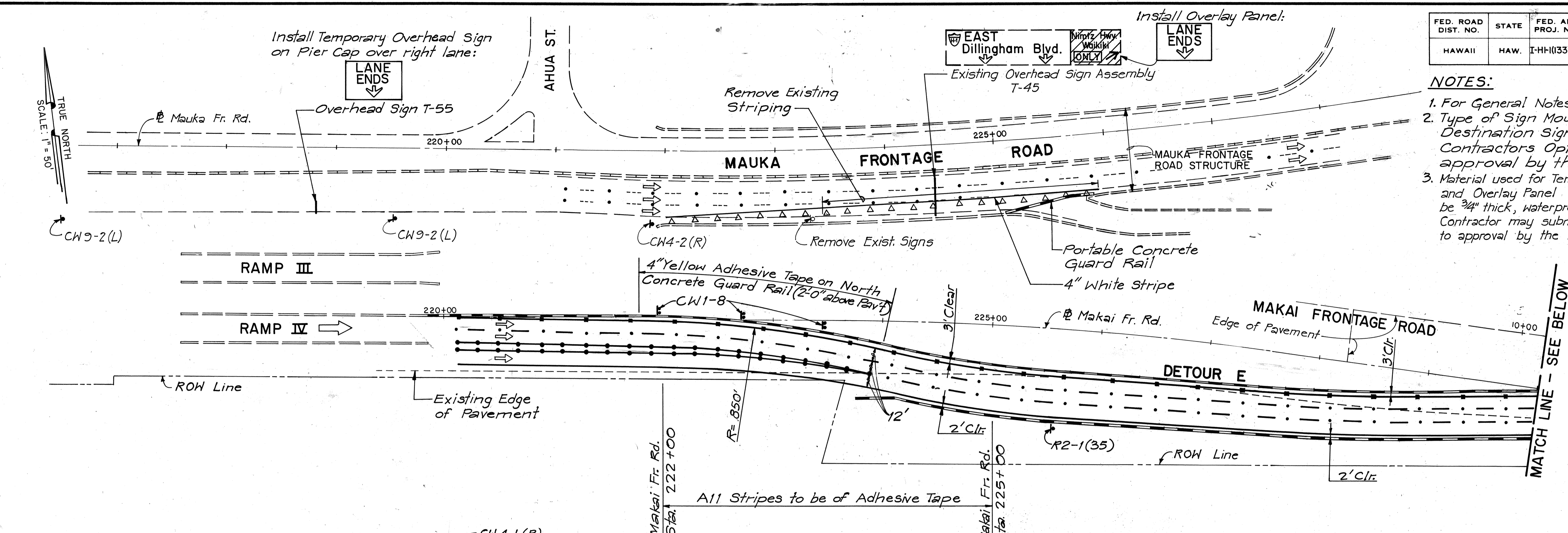

- LEGEND**
- 4" White Stripe (unless shown otherwise)
  - 8" White Stripe with Type C Markers @ 20'
  - 4" Yellow Stripe with Type H Markers @ 40'
  - 4" White Stripe, 10' long, w/ Type C Markers @ 40'
  - 12" White Stop Line
  - 4" White Guide Line
  - New or Relocated Sign
  - Traffic Delineator (Tube)
  - Portable Concrete Guard Rail
  - Direction of Traffic

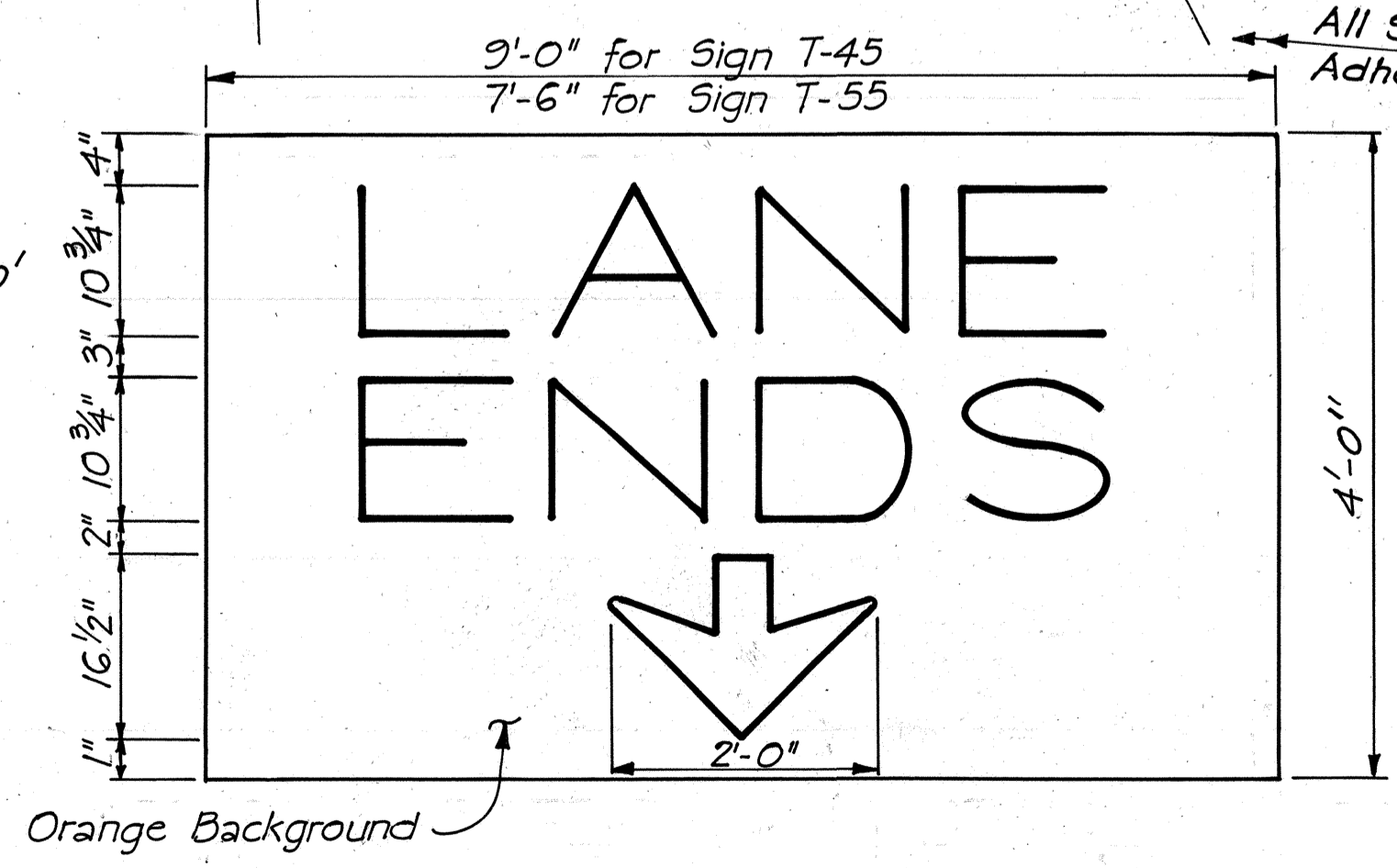

OVERLAY PANEL FOR T-45 & SIGN PANEL T-55

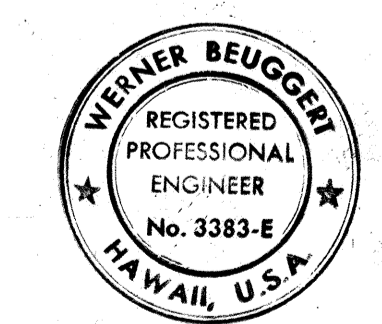

THIS WORK WAS PREPARED BY ME OR UNDER MY SUPERVISION  
*Werner Beugger*

7/15/83	Revised Detour E Alignment. Deleted Detour F.
DATE	REVISION
STATE OF HAWAII DEPARTMENT OF TRANSPORTATION HIGHWAYS DIVISION TRAFFIC PATTERN (B) <b>SIGNING &amp; PAVEMENT MARKINGS PHASE I B</b>	
INTERSTATE ROUTE H-1 PROJECT NO. I-HI-1 (133)17	
SCALE: 1" = 50'	DATE: 4/30/81
SHEET No. P-5 OF P-17 SHEETS	

DATE: \_\_\_\_\_  
 SURVEY PLOTTED BY: \_\_\_\_\_  
 DRAWN BY: \_\_\_\_\_  
 CHECKED BY: \_\_\_\_\_  
 ORIGINAL PLAN NO. \_\_\_\_\_  
 NOTE BOOK NO. \_\_\_\_\_

Contract Change Order No. 27

FED. ROAD DIST. NO.	STATE	FED. AID PROJ. NO.	FISCAL YEAR	SHEET NO.	TOTAL SHEETS
HAWAII	HAW.	I-HI-(133):17	1981	39	159

SUMMARY OF MISCELLANEOUS ITEMS	
ITEM	QUANTITY
Reset Destination Sign	1
Traffic Delineators	53
Type C Pavement Markers	193
Type H Pavement Markers	95
Reflector Marker, RM-9	2

SIGNING SUMMARY			
TYPE	MESSAGE	QUANTITY	
		W/POST	WO/POST
R1-2	YIELD	2	0
R2-1(35)	SPEED LIMIT 35	1	1
R4-7a	KEEP RIGHT	1	0
R6-1(R)	ONE WAY →	0	1
CW1-6	→	1	0
CW3-2	YIELD AHEAD	1	0
CW4-1(R)	↖ MERGE	2	0
R1-1	STOP	1	0
TOTAL NEW SIGNS		7	2
TOTAL RESET SIGNS		2	0

**GENERAL SIGNING NOTES**

- For Legend see Sheet No. P-5
- Signs, Traffic Delineators, and Barricade Warning Lights shall conform to FHWA Publication, "Manual on Uniform Traffic Control Devices", 1978 and "Standard Highway Signs", 1972 and as amended.
- Unless noted otherwise, exact locations of Signs, Barricades, and Delineators will be determined by the Engineer.
- Existing and reusable Signs, Signs from storage, and Delineators shall be reset at locations shown on the Plans, and as directed by the Engineer. Payment for resetting Traffic Delineators shall be considered incidental to various contract items.
- Contractor is responsible for maintaining new and existing signs, barricades and delineators in good condition during Life of Project.
- Superfluous signs, Barricades and Delineators shall be removed and stored on site as directed by the Engineer. Payment shall be considered incidental to various contract items.
- Necessary traffic control devices required for the temporary closure of lanes, detours during working day and any other work that may temporarily obstruct any portion of the roadway shall be considered incidental to various contract items.

**NOTE:**

Shown quantities of signs, and delineators are for estimating purposes only. Contractor shall establish the actual number to be furnished based on reusable material available from site and storage, and as directed by the Engineer.

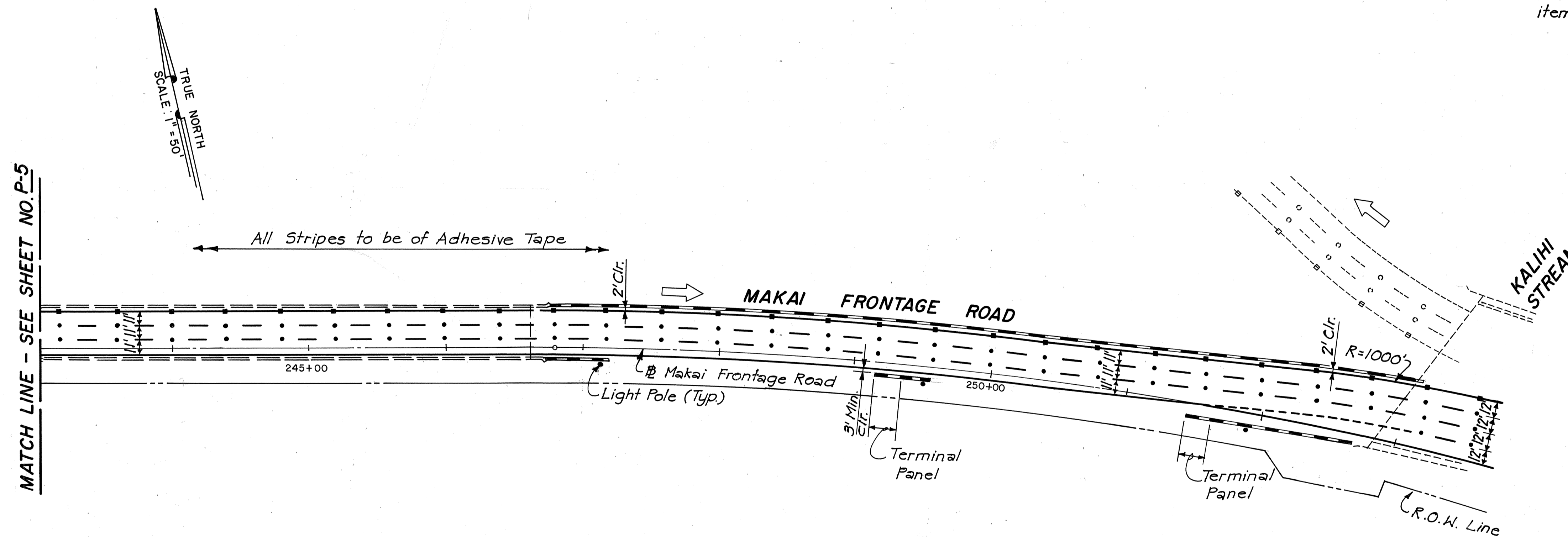

ORIGINAL PLAN	DATE
DESIGNED BY	
NOTED BY	
CHECKED BY	

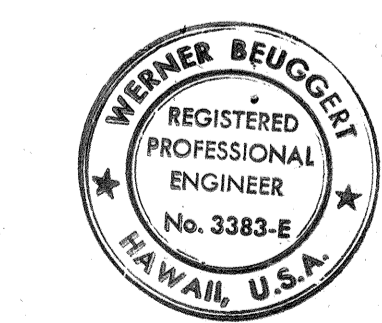

THIS WORK WAS PREPARED BY ME OR UNDER MY SUPERVISION.

STATE OF HAWAII  
DEPARTMENT OF TRANSPORTATION  
HIGHWAYS DIVISION  
TRAFFIC PATTERN (B)  
**SIGNING & PAVEMENT MARKINGS**  
**PHASE I B**

INTERSTATE ROUTE H-1  
PROJECT NO. I-HI-1 (133):17

SCALE: 1" = 50'      DATE: 4/30/81  
SHEET No. P-6 OF P-17 SHEETS

FED. ROAD DIST. NO.	STATE	FED. AID PROJ. NO.	FISCAL YEAR	SHEET NO.	TOTAL SHEETS
HAWAII	HAW.	I-HI-1(133)17	1981	03951	159

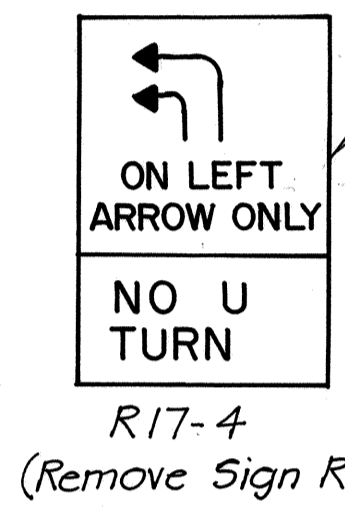
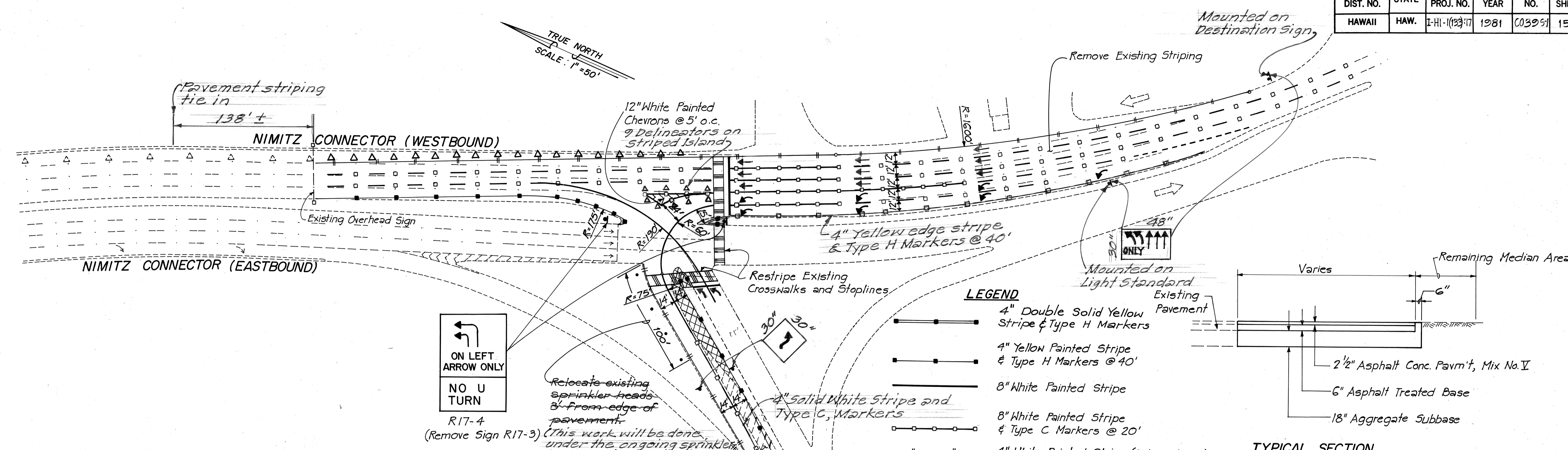

Relocate existing sprinkler heads 8' from edge of pavement. (This work will be done under the ongoing sprinkler landscaping project.)

Remove Existing Striping as necessary.

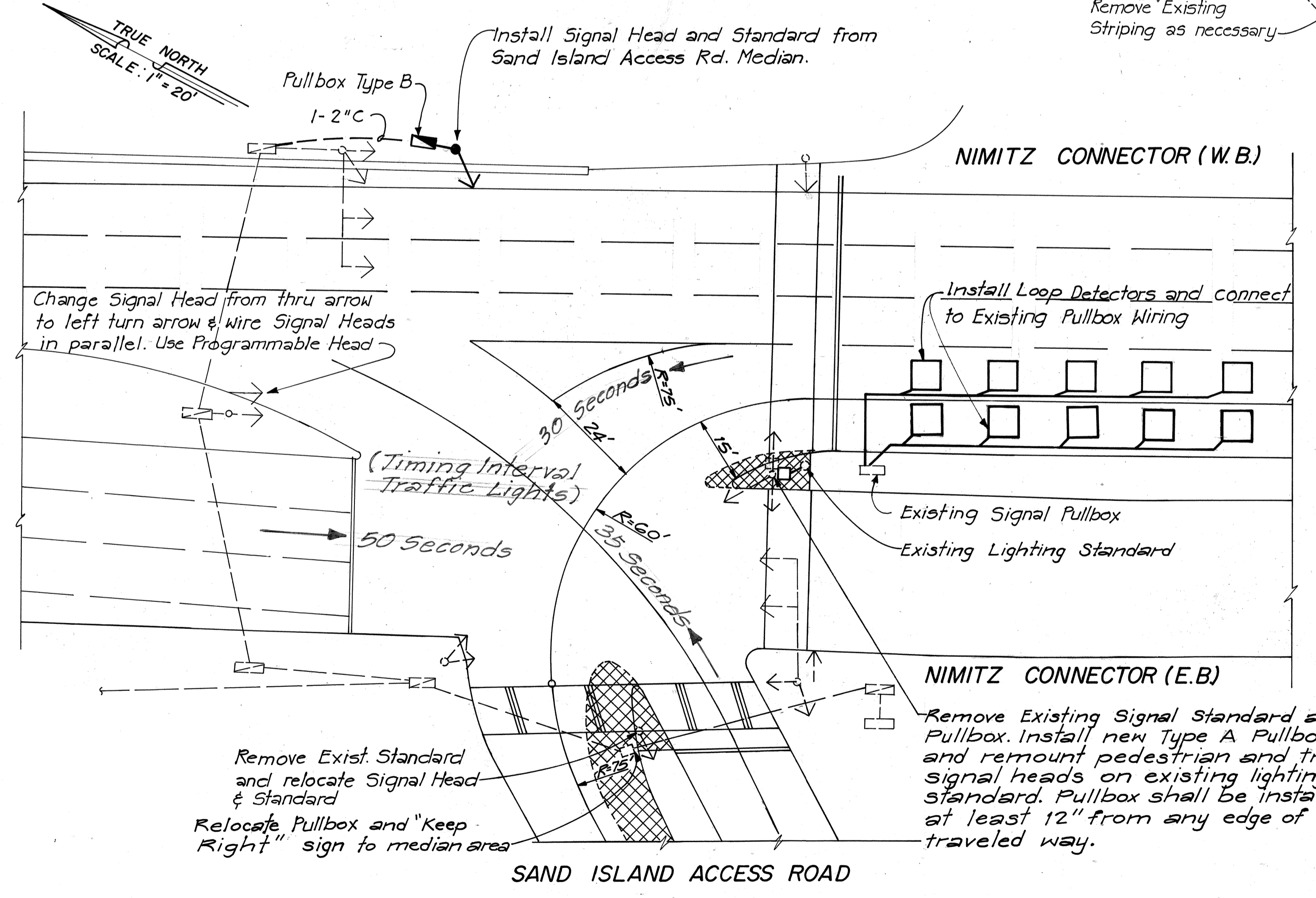

Contract Change Order No. 22

8/22/83	Sheet added to Contract Plan Set for providing 2 left turn lanes from Nimitz Hwy. Westbound to Sand Island Access Rd.
DATE	REVISION
STATE OF HAWAII DEPARTMENT OF TRANSPORTATION HIGHWAYS DIVISION	
<b>ADJUSTMENTS TO INTERSECTION OF SAND ISLAND ACCESS RD. &amp; NIMITZ HWY.</b>	
INTERSTATE ROUTE H-1 PROJECT NO. I-HI-1(133):17	
SCALE: AS SHOWN	DATE: 6/14/83
SHEET No. 1 OF 1 SHEETS	

C.O.39 S-1

0-5-4

DATE	_____
SURVEY PLOTTED BY	_____
DRAWN BY	_____
DESIGNED BY	_____
QUANTITIES BY	_____
CHECKED BY	_____
ORIGINAL PLAN	_____
NOTE BOOK	_____
No.	_____

FED. ROAD DIST. NO.	STATE	FED. AID PROJ. NO.	FISCAL YEAR	SHEET NO.	TOTAL SHEETS
HAWAII	HAW.	I-HI-1(133):17	1981	003952	159

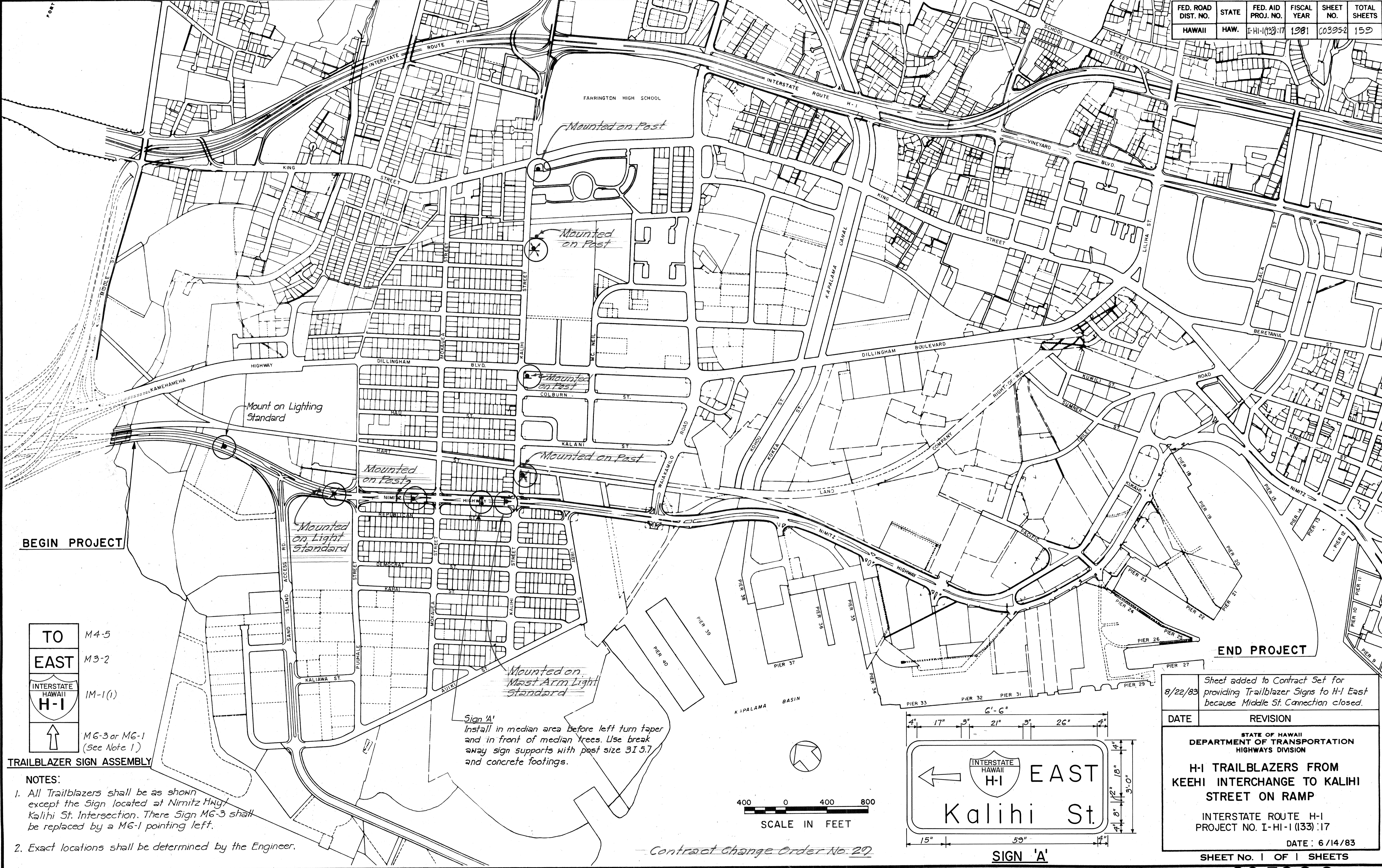

BEGIN PROJECT

END PROJECT

TO	M4-5
EAST	M3-2
INTERSTATE HAWAII H-1	IM-1(i)
↑	M6-3 or M6-1 (See Note 1)

**TRAILBLAZER SIGN ASSEMBLY**

- NOTES:
- All Trailblazers shall be as shown except the Sign located at Nimitz Hwy/Kalihi St. Intersection. There Sign M6-3 shall be replaced by a M6-1 pointing left.
  - Exact locations shall be determined by the Engineer.

Sign 'A'  
Install in median area before left turn taper and in front of median trees. Use break away sign supports with post size 3I 5.7 and concrete footings.

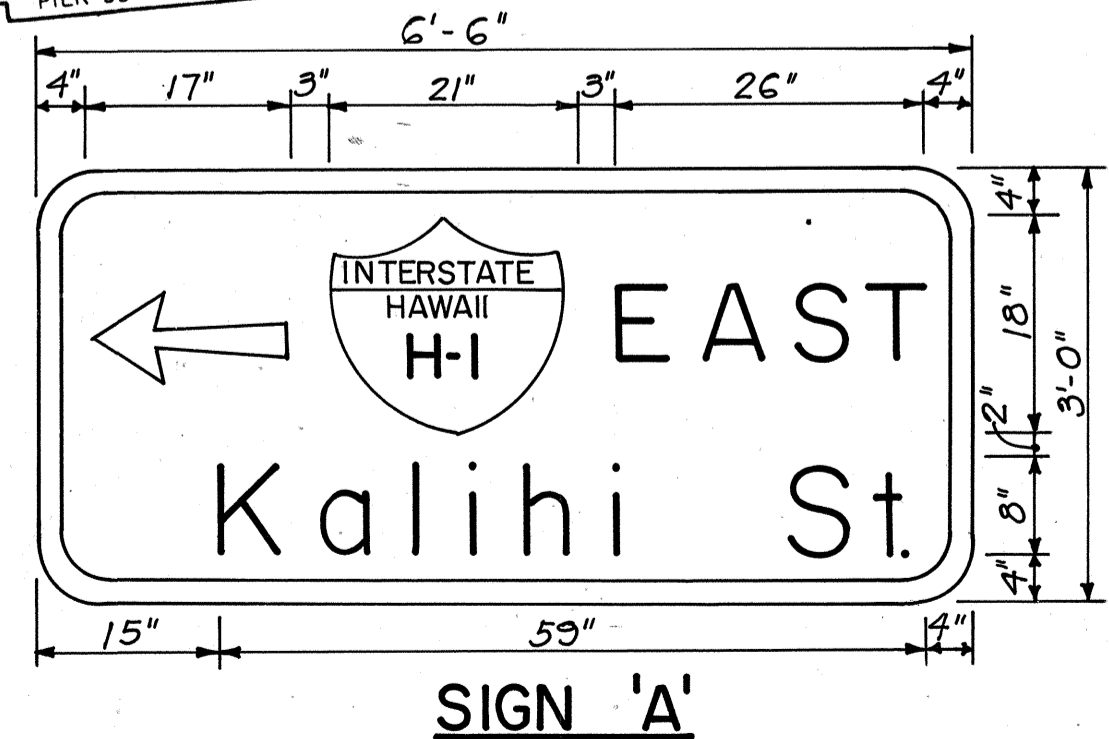
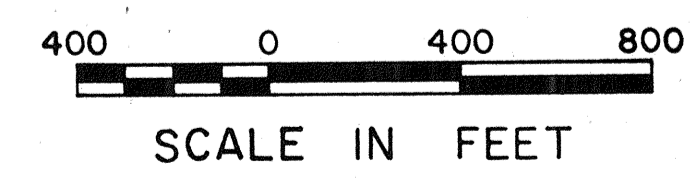

8/22/83 Sheet added to Contract Set for providing Trailblazer Signs to H-1 East because Middle St. Connection closed.

DATE	REVISION

STATE OF HAWAII  
DEPARTMENT OF TRANSPORTATION  
HIGHWAYS DIVISION

**H-1 TRAILBLAZERS FROM  
KEEHI INTERCHANGE TO KALIHI  
STREET ON RAMP**

INTERSTATE ROUTE H-1  
PROJECT NO. I-HI-1(133):17

DATE: 6/14/83  
SHEET NO. 1 OF 1 SHEETS

C.O. 39S-2

DATE	
SURVEY PLOTTED BY	
DRAWN BY	
DESIGNED BY	
QUANTITIES BY	
CHECKED BY	
ORIGINAL PLAN	
NOTE BOOK	
NO.	

Contract Change Order No. 29

FED. ROAD DIST. NO.	STATE	FED. AID PROJ. NO.	FISCAL YEAR	SHEET NO.	TOTAL SHEETS
HAWAII	HAW.	I-HI-1(133)J	1981	40	159

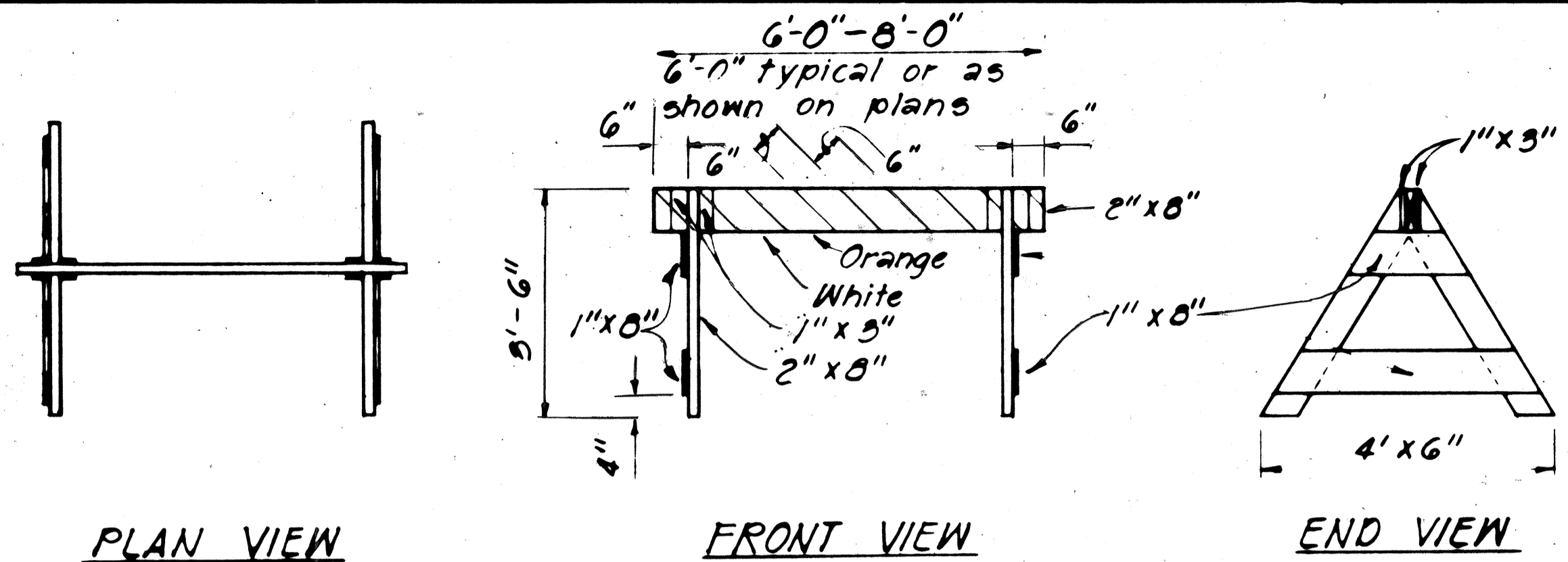

**TYPE I BARRICADE**  
Scale: 1/2" = 1'-0"

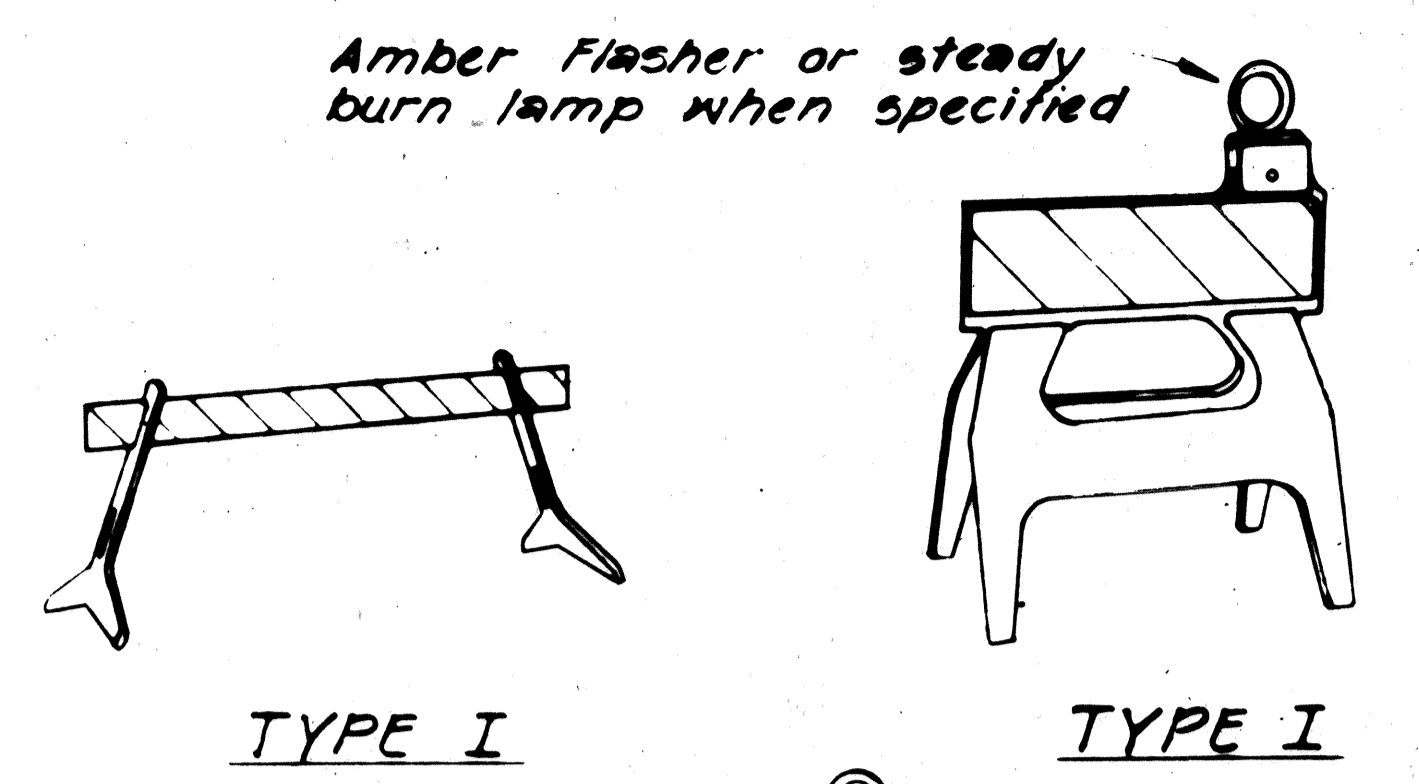

TYPE I

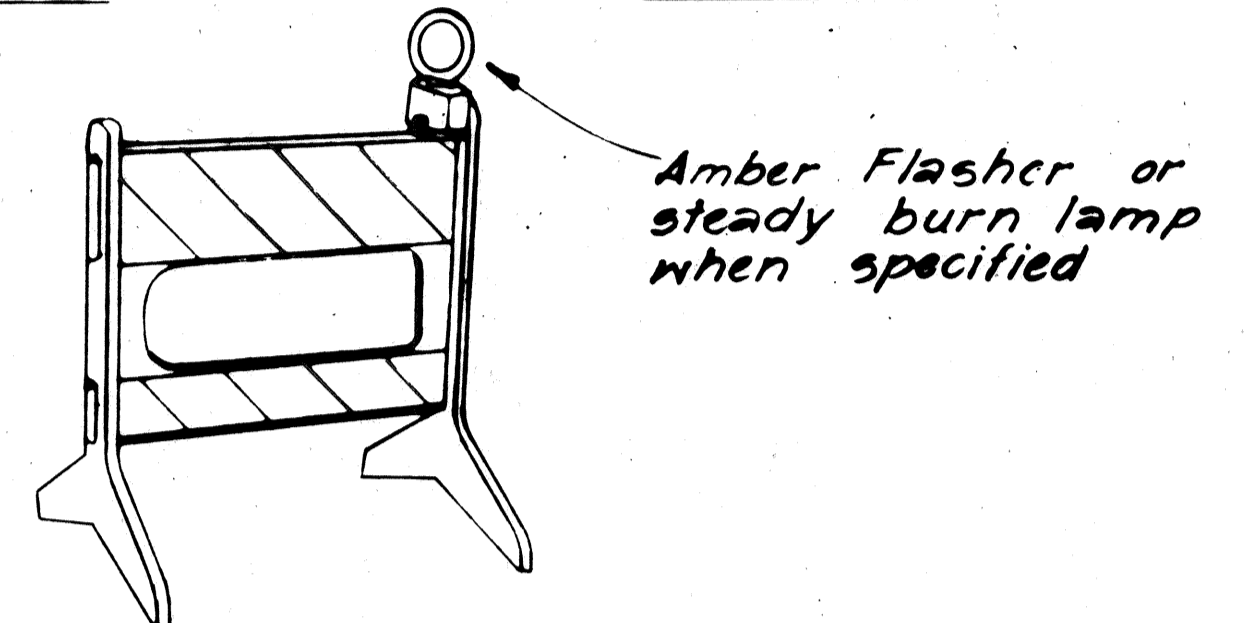

TYPE II

**GENERAL NOTES**

1. The Contractor shall construct, install and maintain the barricades at the locations shown on the Plans.
2. The barricades shall be left in place or relocated upon completion of the project as ordered by the Engineer and are to become State property, unless otherwise specified.
3. The orange and white stripes shall slant downward toward the side on which traffic is to pass and shall be reflectorized with reflective sheeting.
4. Both faces of the barricade rails shall be striped. See Striping Detail Arrangement.
5. Contractor may submit alternate designs for approval.
6. Barricade details shall conform to the "Manual on Uniform Traffic Control Devices for Streets and Highways," 1971, by the Federal Highway Administration and as amended.
7. If wooden rails are used, 26 ga. galv. steel sheet shall be first tacked on to the rails and then overlayed with reflective sheeting.

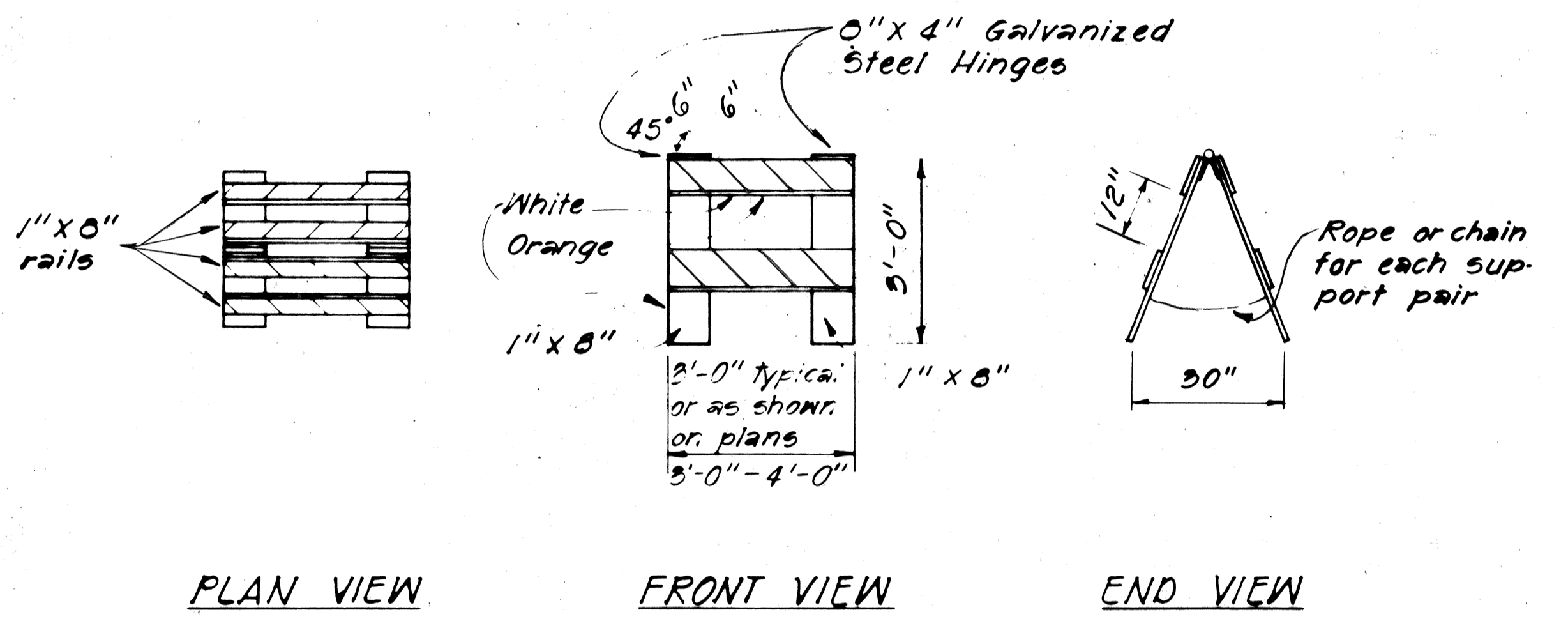

**TYPE II BARRICADE**  
Scale: 1/2" = 1'-0"

**PLASTIC MOLDED BARRICADE OPTIONS\***

Not to Scale  
\* Shop Drawings must be submitted for approval.

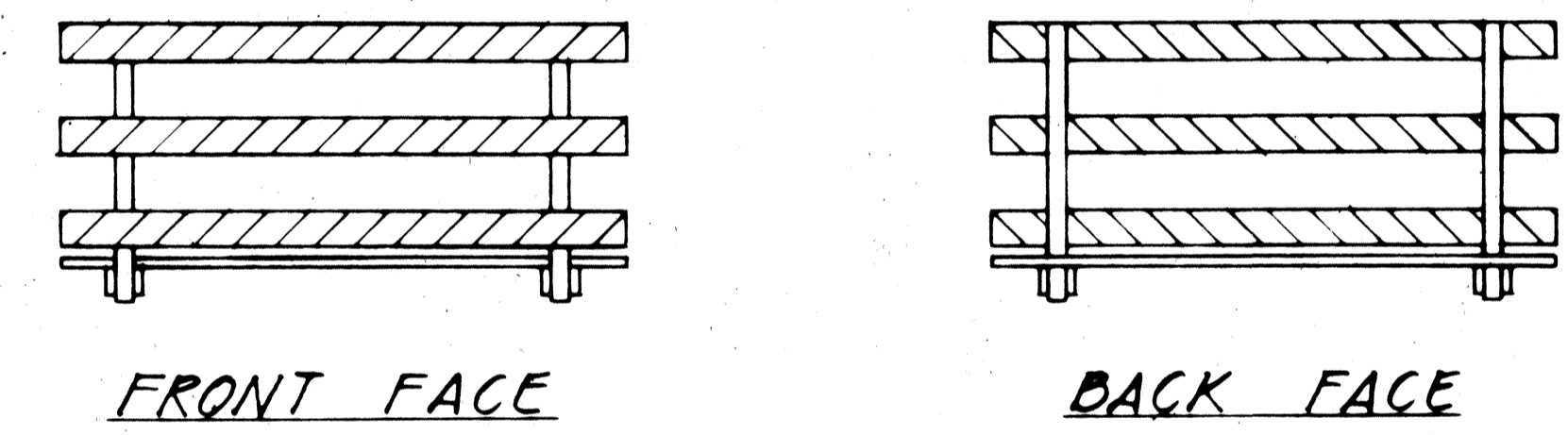

FRONT FACE      BACK FACE

**BARRICADE STRIPING DETAILS**

Not to Scale

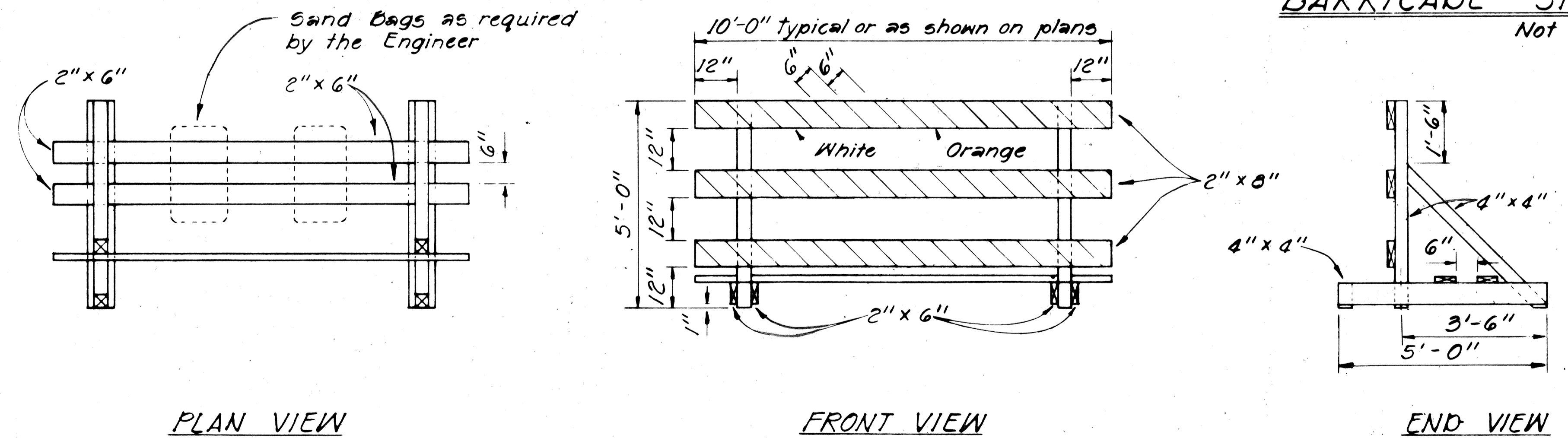

**TYPE III BARRICADE**  
Scale: 1/2" = 1'-0"

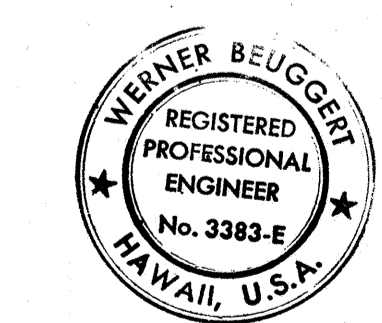

THIS WORK WAS PREPARED BY ME OR UNDER MY SUPERVISION.  
Werner Beuggert

STATE OF HAWAII  
DEPARTMENT OF TRANSPORTATION  
HIGHWAYS DIVISION

**TYPICAL DETAILS  
BARRICADES**

INTERSTATE ROUTE H-1  
PROJECT NO. I-HI-1(133)J

SCALE: AS SHOWN      DATE: 4/30/81  
SHEET NO. P-7 OF P-17 SHEETS

FED. ROAD DIST. NO.	STATE	FED. AID PROJ. NO.	FISCAL YEAR	SHEET NO.	TOTAL SHEETS
HAWAII	HAW.	5-HI-1(133):17	1981	41	159

**GENERAL NOTE**

Barricade Type, Placement, and Arrangement shall be as shown on the Construction Plans.

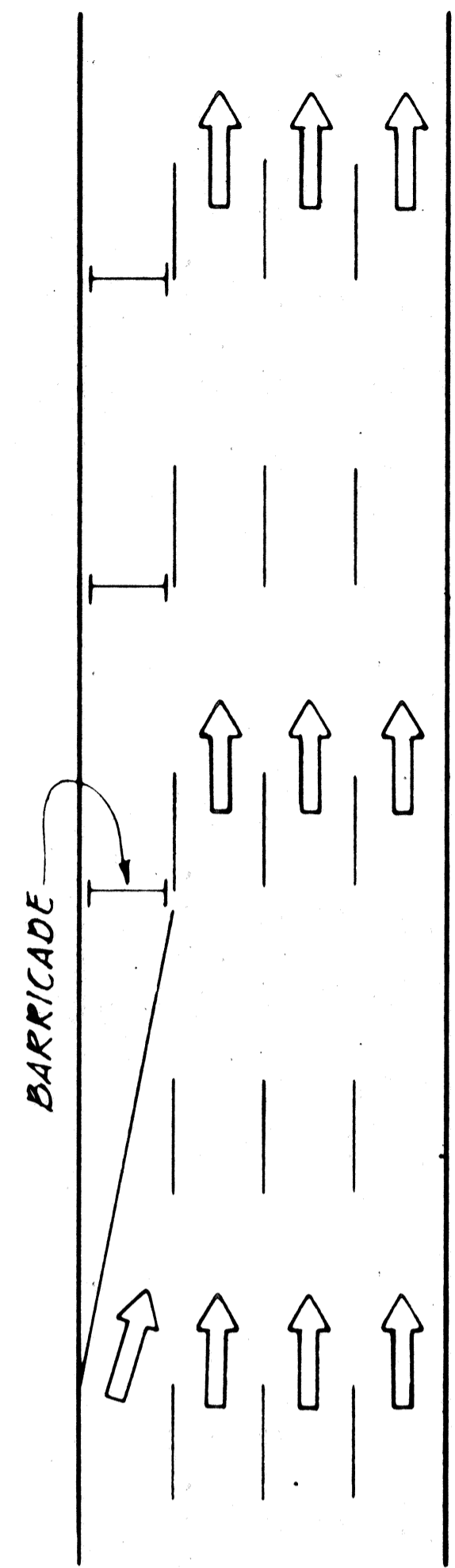

**ROADWAY DELINEATION TO THE RIGHT**  
NOT TO SCALE

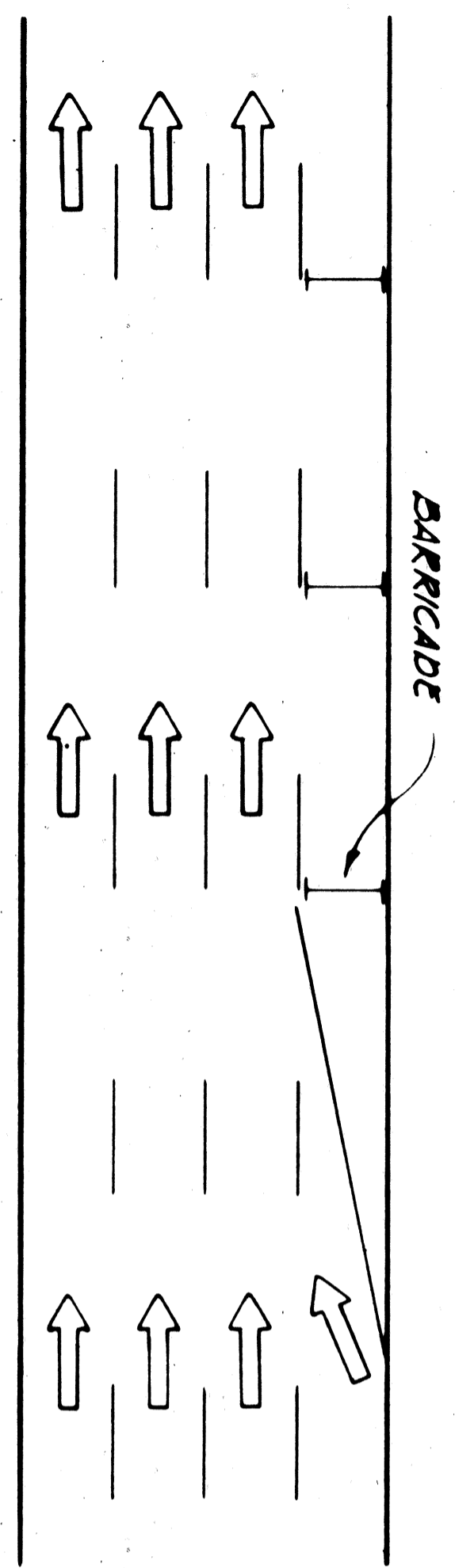

**ROADWAY DELINEATION TO THE LEFT**  
NOT TO SCALE

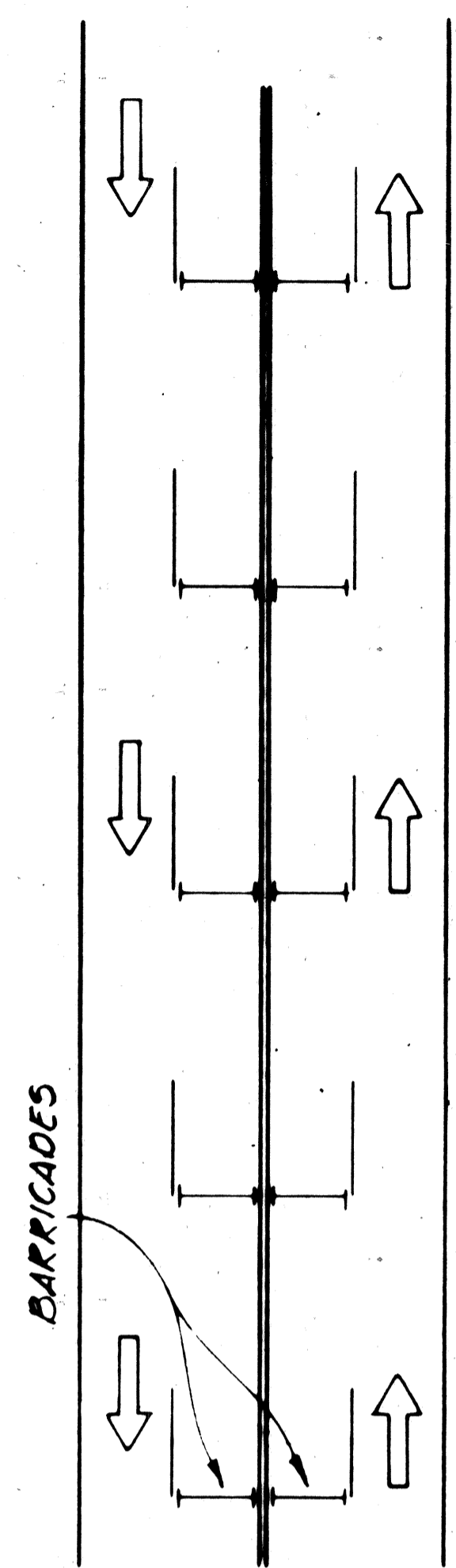

**ROADWAY DELINEATION FOR 2-WAY TRAFFIC**  
NOT TO SCALE

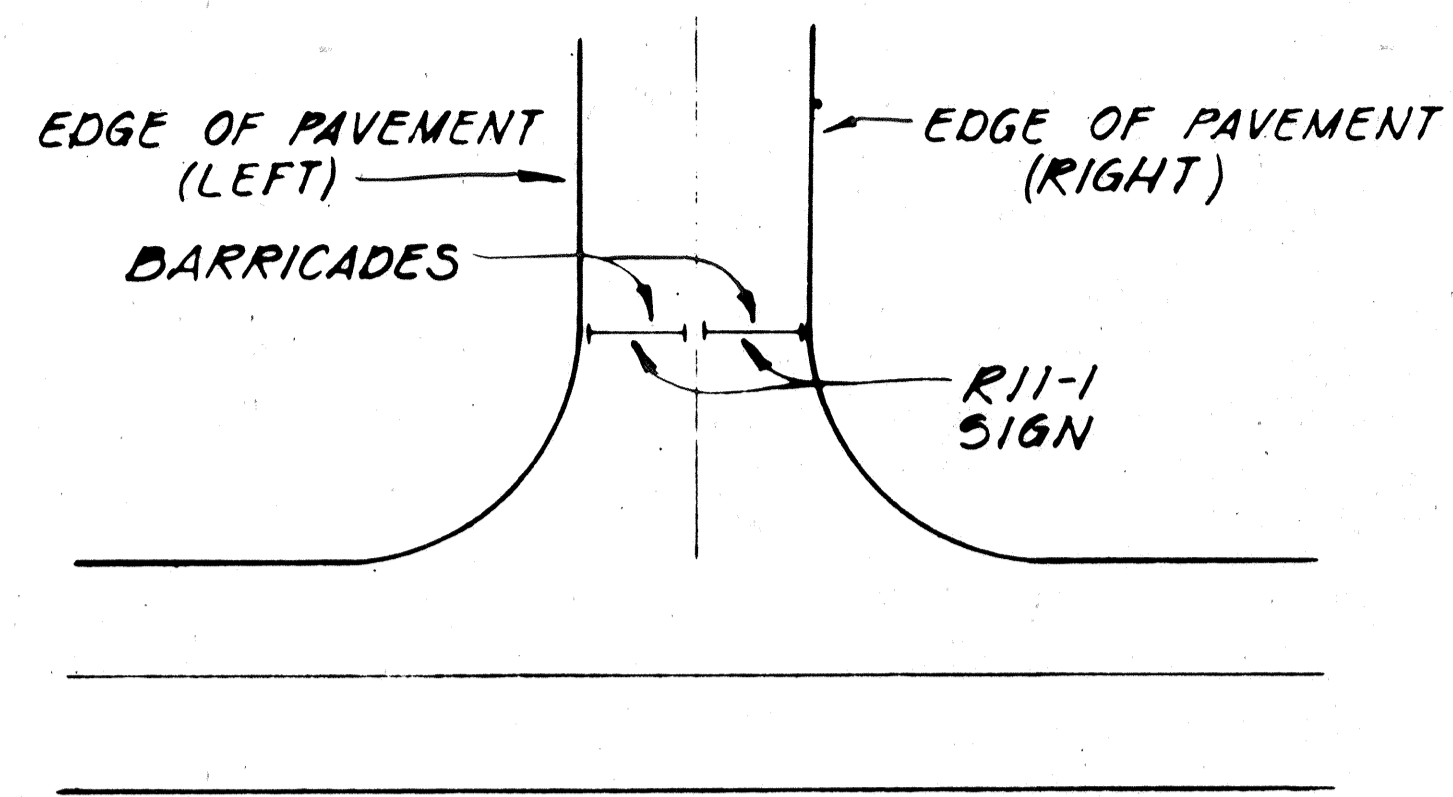

**ROADWAY CLOSED**  
NOT TO SCALE

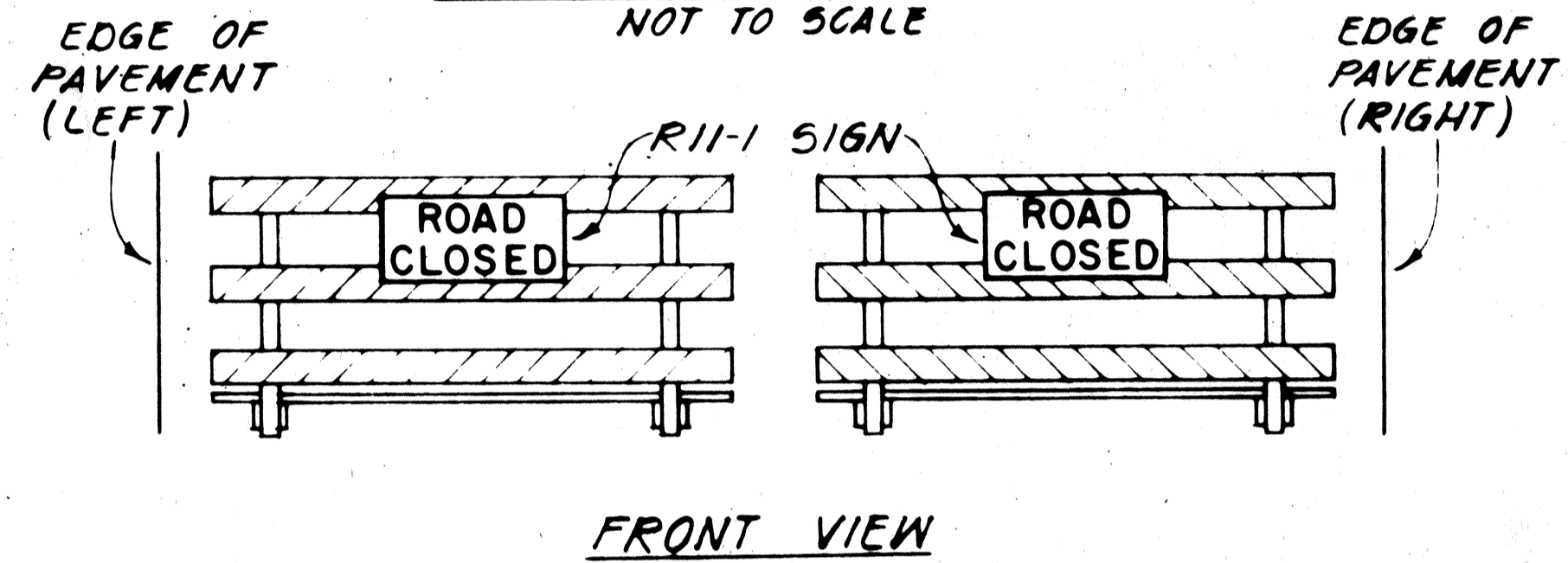

**FRONT VIEW**

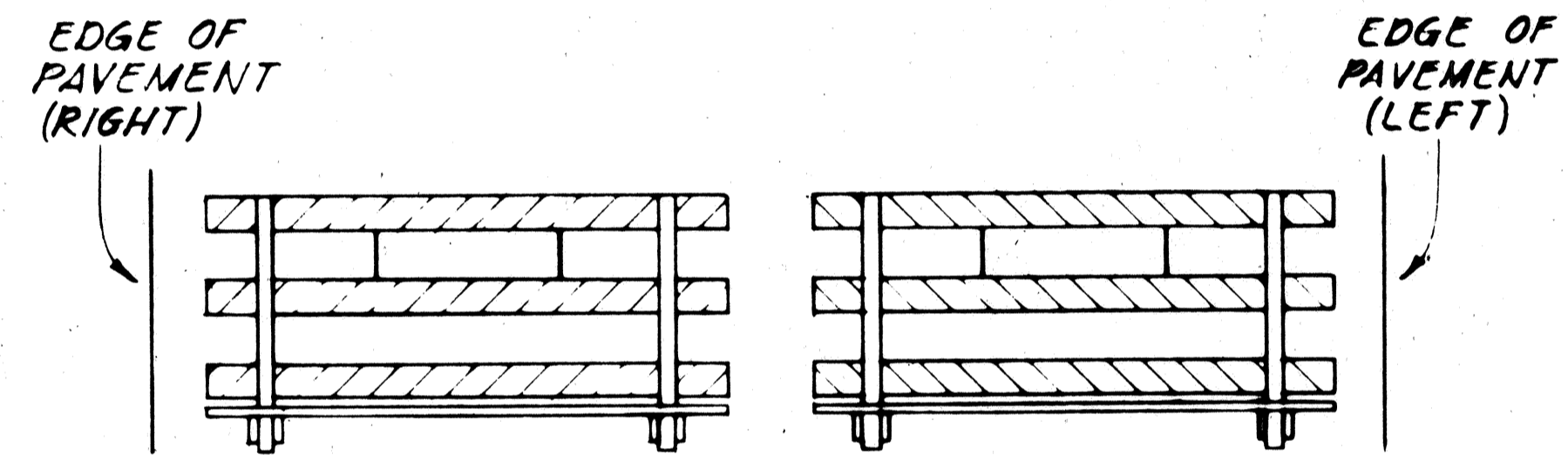

**BACK VIEW**

**BARRICADE STRIPING ARRANGEMENT**  
NOT TO SCALE

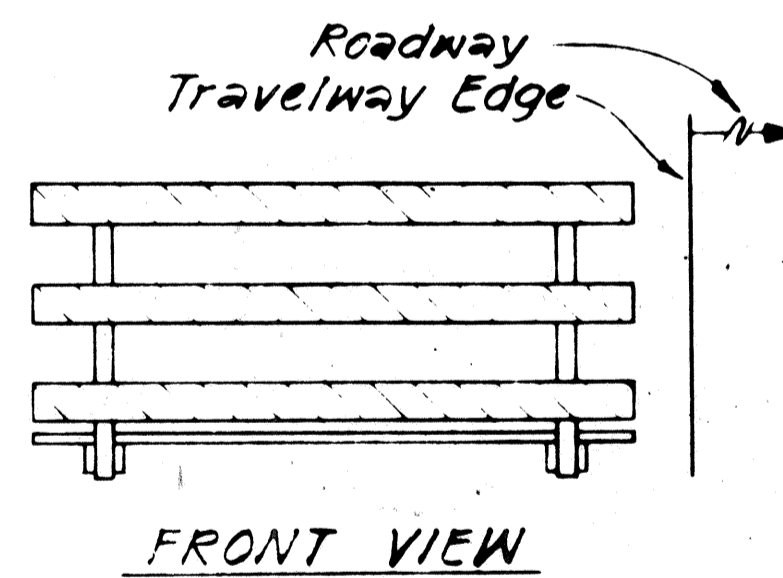

**FRONT VIEW**

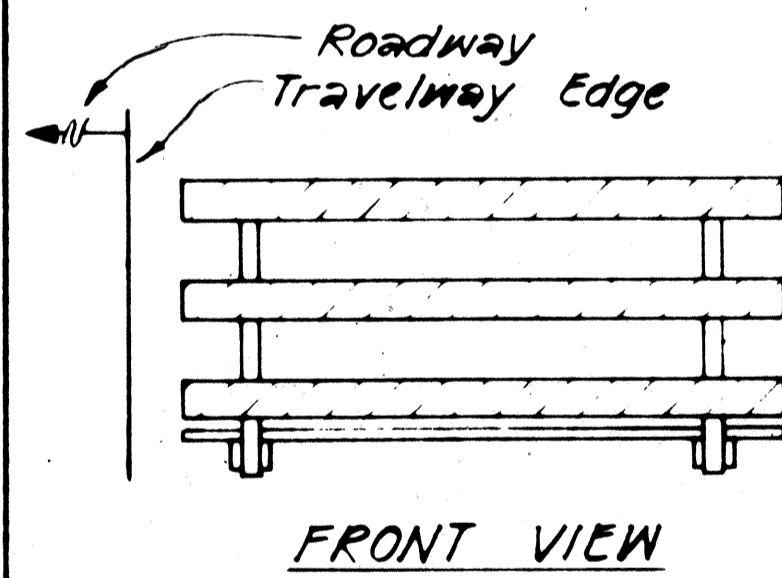

**FRONT VIEW**

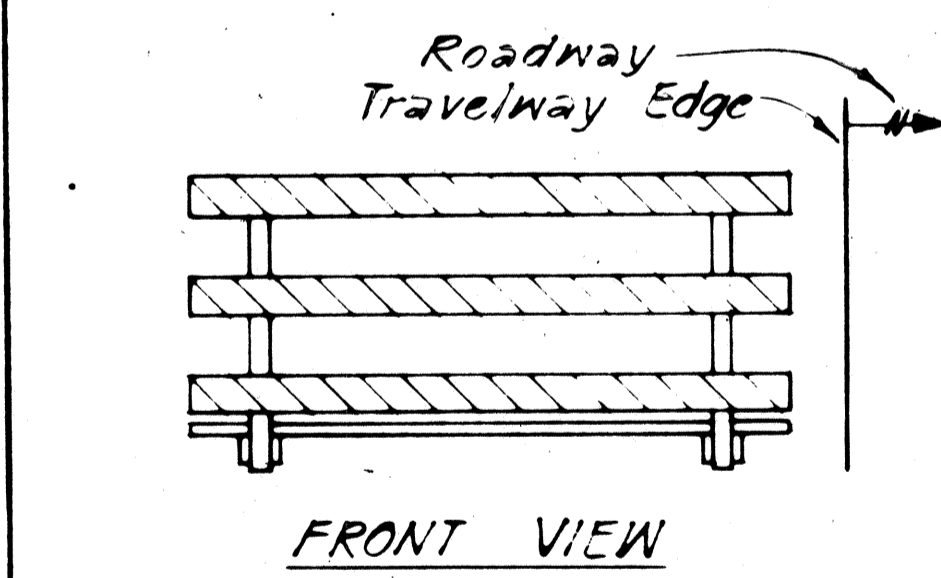

**FRONT VIEW**

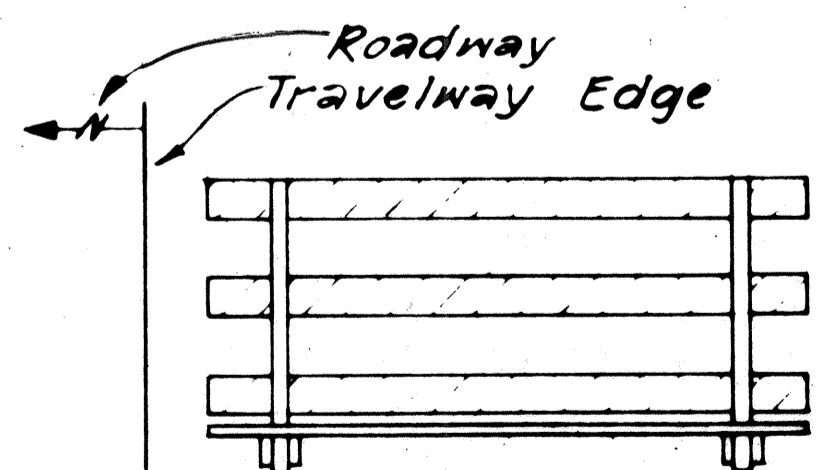

**BACK VIEW**

**BARRICADE STRIPING ARRANGEMENT**  
NOT TO SCALE

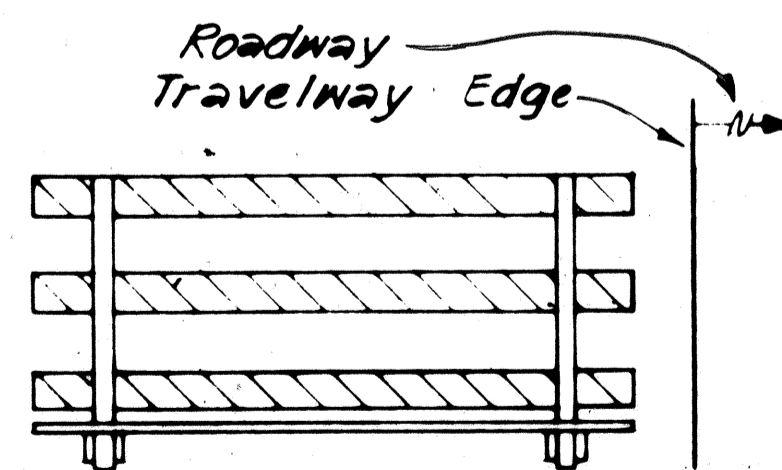

**BACK VIEW**

**BARRICADE STRIPING ARRANGEMENT**  
NOT TO SCALE

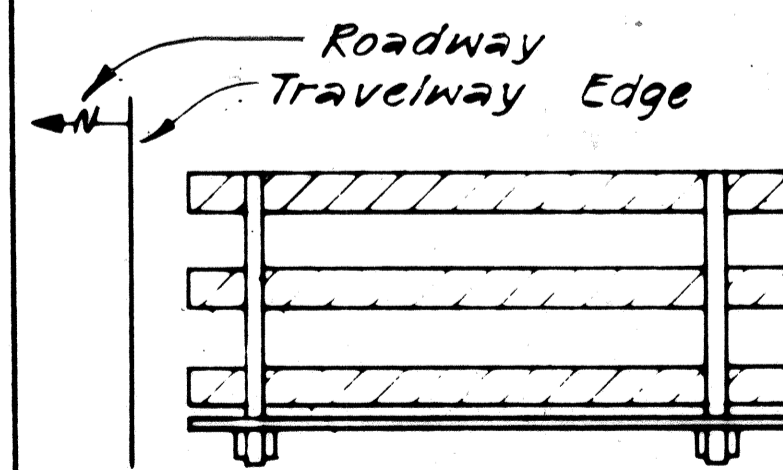

**BACK VIEW**

**BARRICADE STRIPING ARRANGEMENT**  
NOT TO SCALE

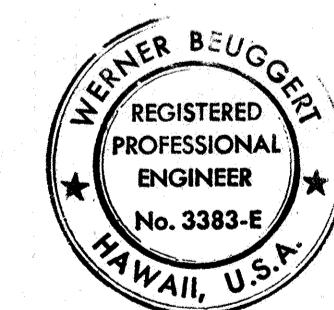

THIS WORK WAS PREPARED BY ME OR UNDER MY SUPERVISION.  
*Werner Beuggert*

STATE OF HAWAII  
DEPARTMENT OF TRANSPORTATION  
HIGHWAYS DIVISION

**TYPICAL DETAILS**  
BARRICADE STRIPING DETAILS

INTERSTATE ROUTE H-1  
PROJECT NO. I-HI-1 (133):17

SCALE: AS SHOWN      DATE: 4/30/81

**SHEET No. P-8 OF P-17 SHEETS**

FED. ROAD DIST. NO.	STATE	FED. AID PROJ. NO.	FISCAL YEAR	SHEET NO.	TOTAL SHEETS
HAWAII	HAW.	I-HI-(133)17	1981	42	159

**GENERAL NOTES**

- Signs shall be placed in conformance with positions shown and described in the "Manual on Uniform Traffic Control Devices for Streets and Highways", 1978, Part II, Section 2A-21, as amended, and as supplemented herein.
- Signs 48" and wider or larger than 10 sq. ft. in area shall be mounted on two sign posts except as noted below.
- Signs 48" and wider or larger than 10 sq. ft. in area may be mounted on other than two sign posts (i.e. on highway lighting poles)
  - Signs larger than 10 sq. ft. and less than 28 sq. ft. in area shall be mounted with a minimum of two sets of band brackets and back braces.
  - Signs larger than 28 sq. ft. in area shall be mounted with a minimum of three sets of band brackets and back braces.
- All parking restriction signs with arrows shall be mounted 45° to the line of traffic flow.
- Sign posts shall extend 3/2" above each sign, where required, for attachment of City and County street name signs.
- (R) or (L) indicates right or left and shall be shown on the plans.
- See plans for special details.
- \*\* 8. The minimum lateral distances shown are guidelines and shall be exceeded whenever possible. The Contractor shall place signs at the maximum practical lateral distance from the edge of the traveled way up to 30 feet and shall utilize protected locations whenever possible. Final locations of all signs shall be approved by the Engineer.
- Signs in medians shall be placed at midpoint of median up to a maximum distance of 30 feet from the edge of traveled way. When appropriate, signs for opposing directions shall be placed back to back.

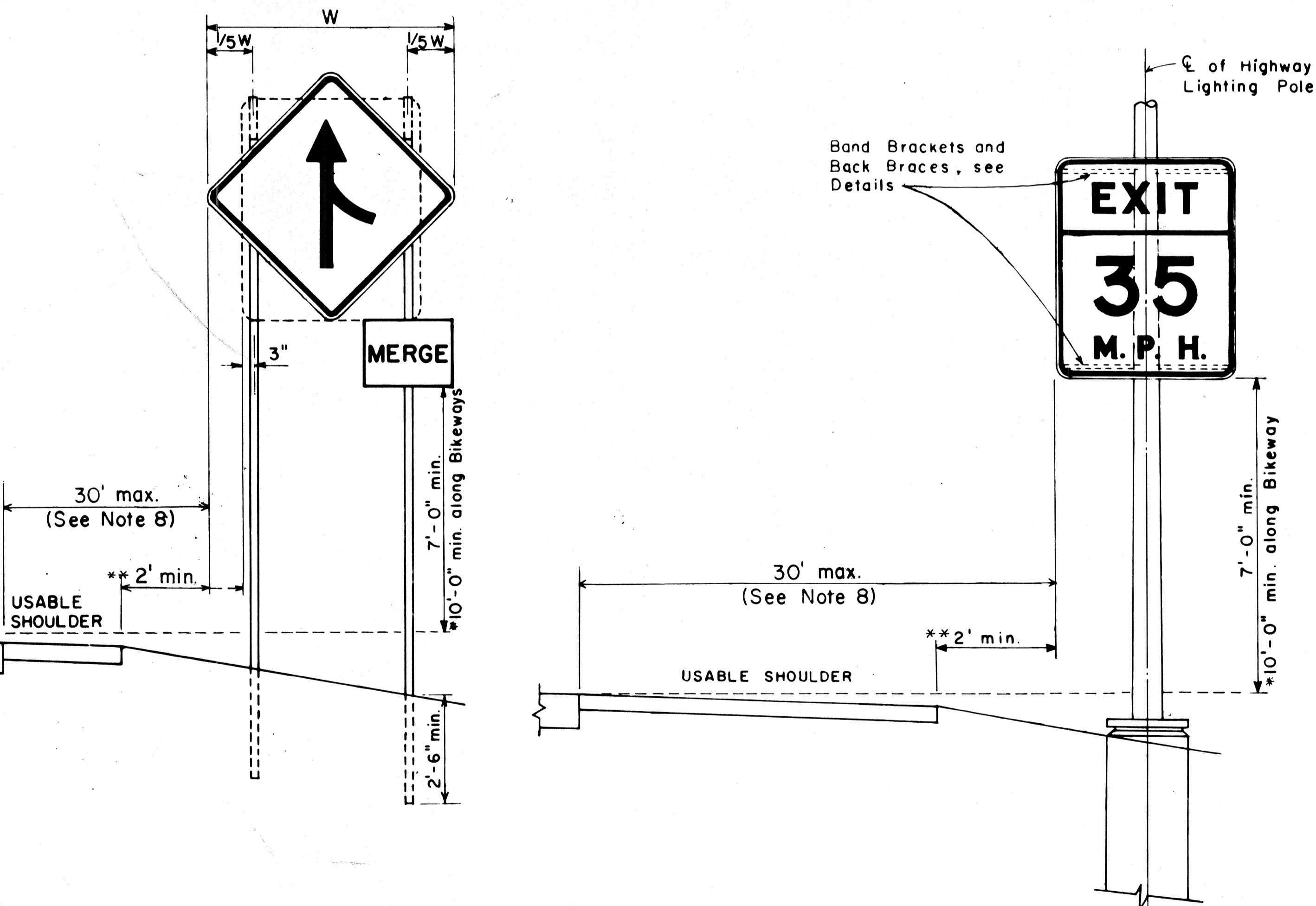
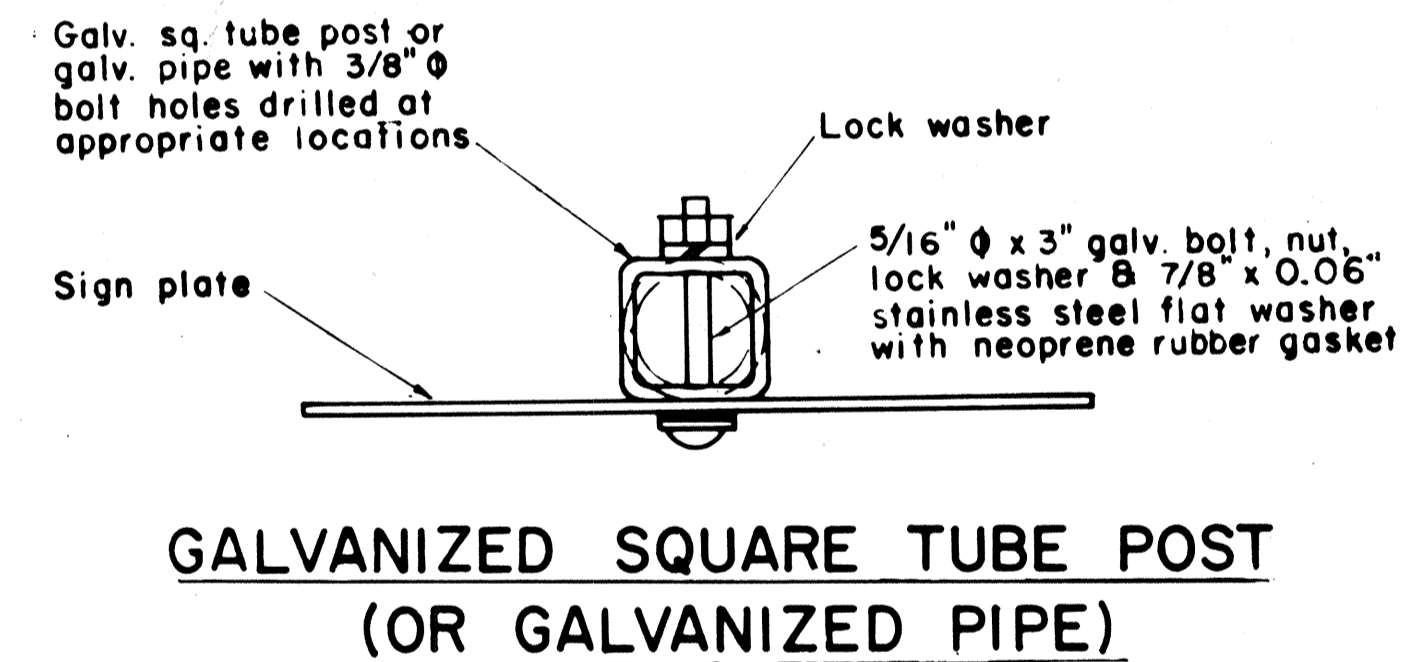
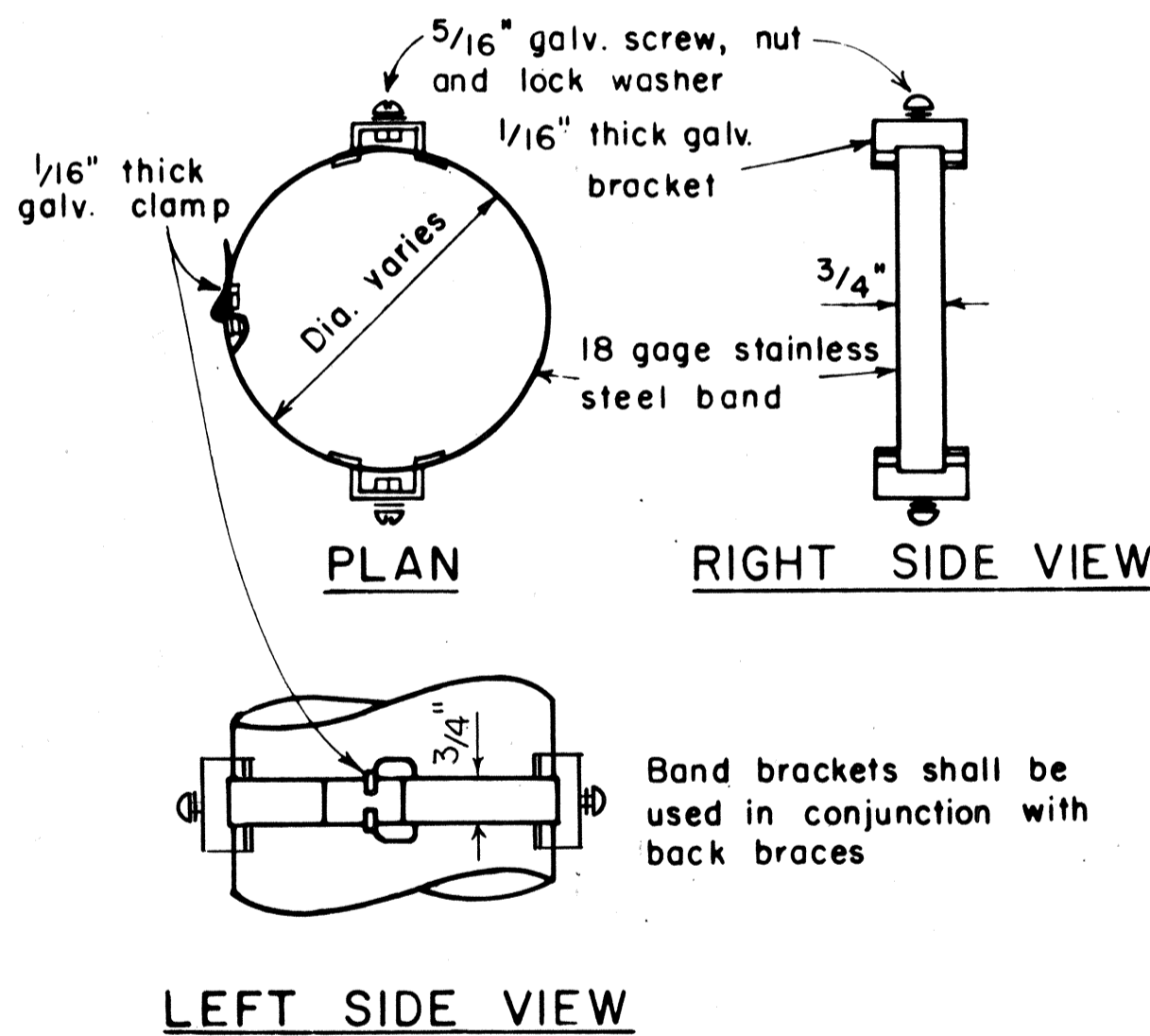
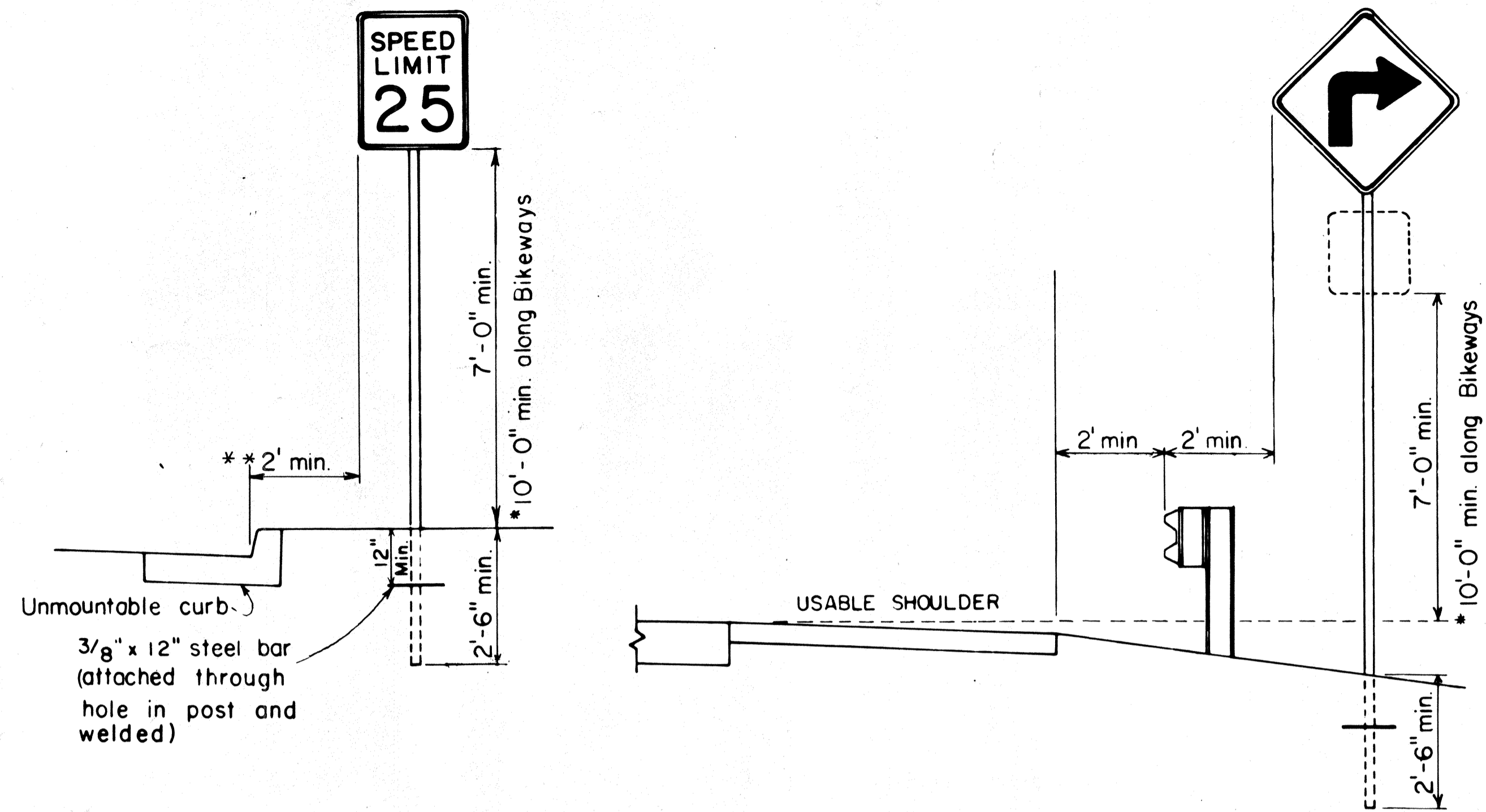
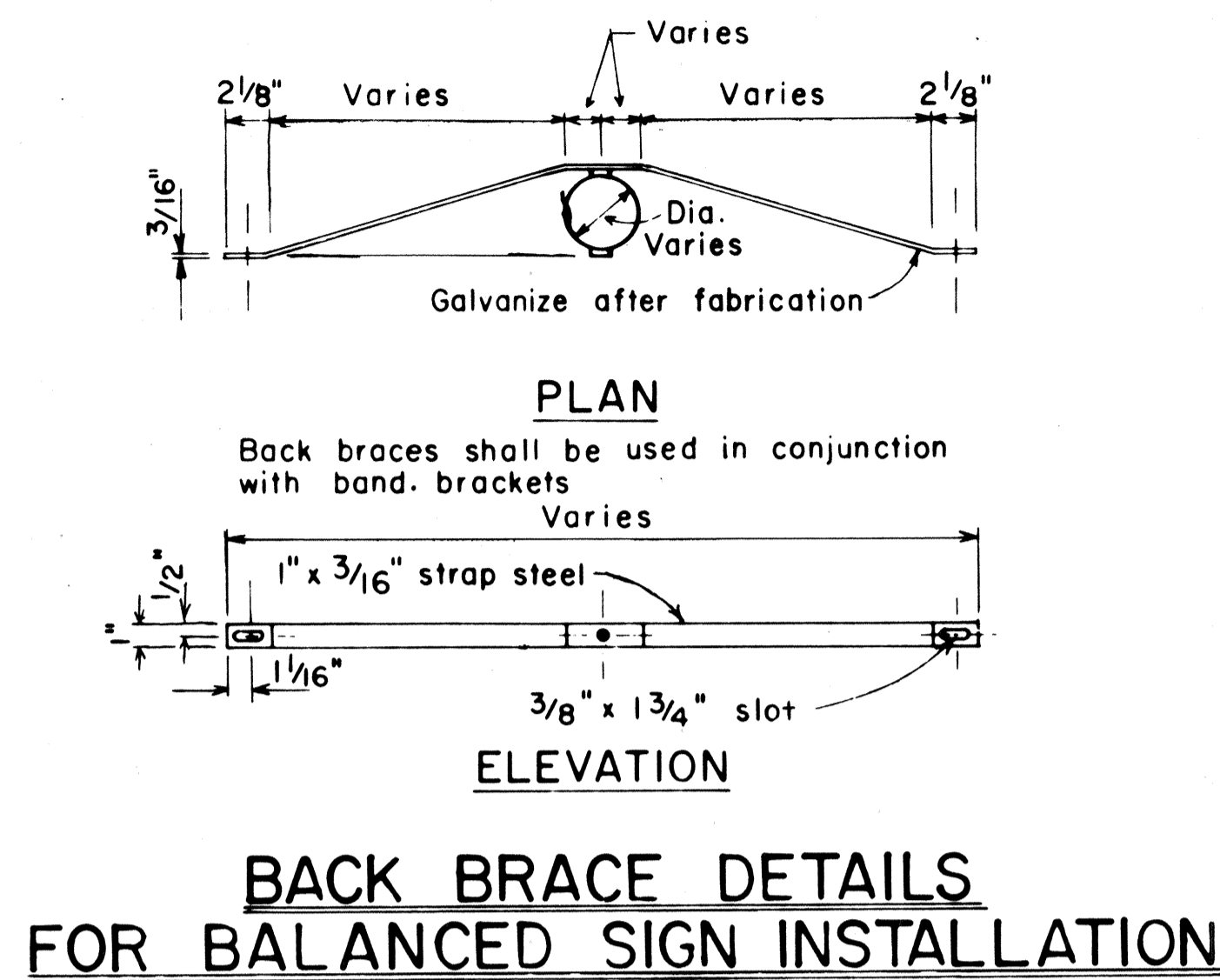

**TYPICAL MOUNTING DETAILS**

NOT TO SCALE

NO.	REVISION	APPROVED BY	DATE
1	Supersedes Sht. DT-100 approved 12/30/69	H.T.	11/15/77
2	Revised depth of signpost	H.T.	5/8/79
3	Added Notes No. 8 & No. 9	H.T.	5/15/79
4	Revised Gen. Note #4 & Mounting Details	H.T.	4/23/80
5	Revised General Notes, Lateral Sign Locations and Mounting Details	H.T.	5/15/81

APPROVAL RECOMMENDED:  
*Eishi Tanaka* 11/10/77  
 TRAFFIC ENGINEER DATE

APPROVED:  
*Harbour S. Gafai* 11/15/77  
 ASSISTANT CHIEF, ENGINEERING DATE

STATE OF HAWAII  
 DEPARTMENT OF TRANSPORTATION  
 HIGHWAYS DIVISION

**STANDARD DETAILS**  
 MISCELLANEOUS SIGN DETAILS

Not to scale June, 1977

DATE	_____
SURVEY PLOTTED BY	_____
DESIGNED BY	_____
QUANTITIES BY	_____
CHECKED BY	_____
NO.	_____

**HEIGHT AND LATERAL LOCATION OF SIGNS TYPICAL INSTALLATION**



R1-1 30" x 30"  
R1-1-A 36" x 36"  
**4-WAY**  
R1-3 12" x 6"  
R1-3-A 18" x 9"

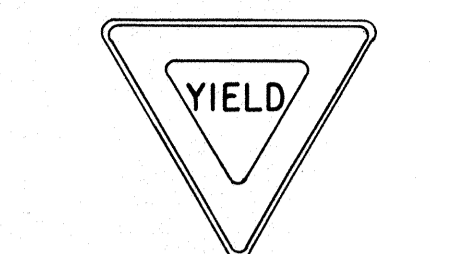

R1-2 36" x 36" x 36"  
R1-2-A 48" x 48" x 48"



R2-1(50) 24" x 30"  
R2-1(50)-A 48" x 60"

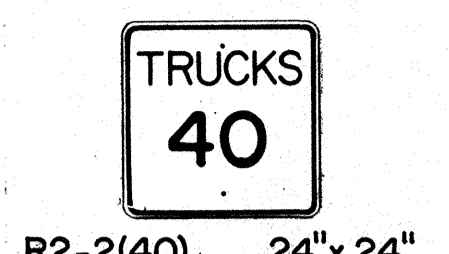

R2-2(40) 24" x 24"  
R2-2(40)-A 48" x 48"

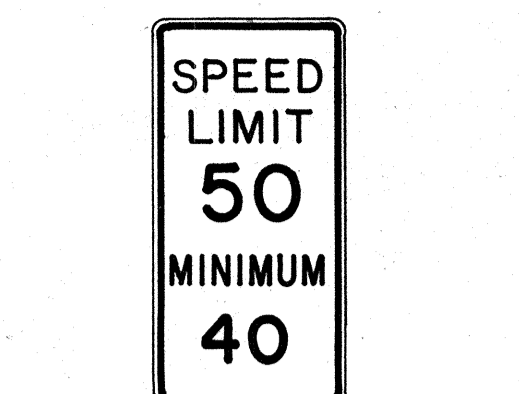

R2-4a(50/40) 24" x 48"  
R2-4a(50/40)-A 48" x 96"

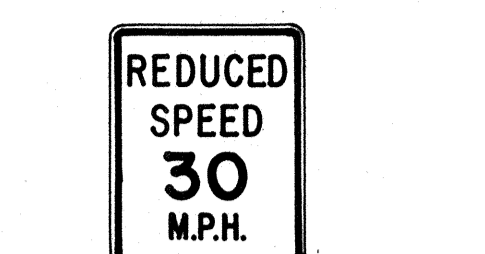

R2-5b(30) 24" x 30"  
R2-5b(30)-A 48" x 60"



R3-1 24" x 24"  
24" x 18"  
R3-1-A 48" x 48"  
48" x 36"



R3-2 24" x 24"  
24" x 18"  
R3-2-A 48" x 48"  
48" x 36"

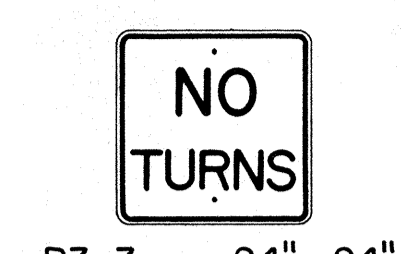

R3-3 24" x 24"  
R3-3-A 48" x 48"

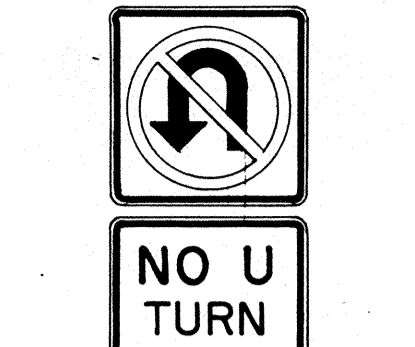

R3-4 24" x 24"  
24" x 18"  
R3-4-A 48" x 48"  
48" x 36"

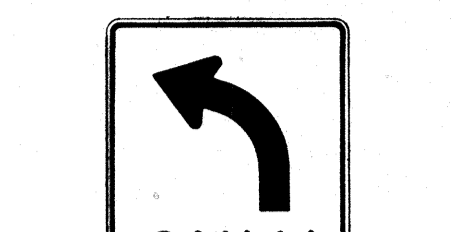

R3-5(L) 30" x 36"  
R3-5(L)-A 48" x 60"

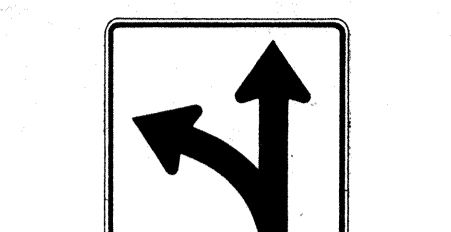

R3-6(L) 30" x 36"  
R3-6(L)-A 48" x 60"



R3-7(R) 30" x 30"  
R3-7(R)-A 48" x 48"



R3-8(L) 30" x 30"  
R3-8(L)-A 36" x 36"  
R3-8(L)-B 48" x 48"

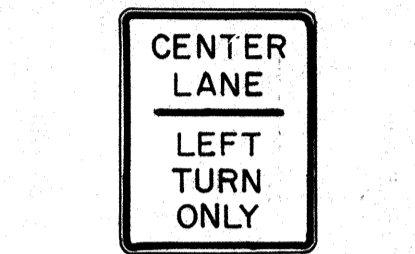

R3-9 24" x 30"



R4-1 24" x 30"



R4-2 24" x 30"



R4-3 24" x 30"  
R4-3-A 48" x 60"

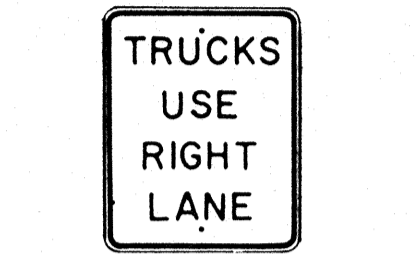

R4-5 24" x 30"



R4-6(500) 24" x 30"



R4-7 24" x 30"  
24" x 18"

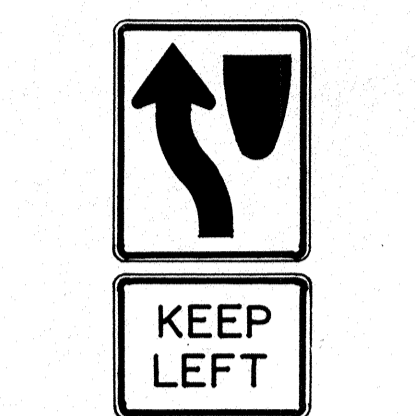

R4-8 24" x 30"  
24" x 18"

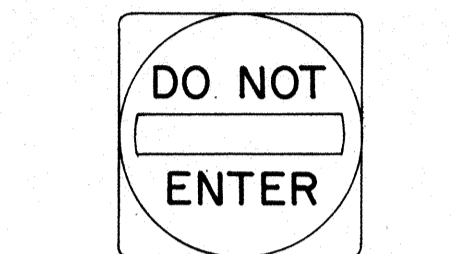

R5-1 30" x 30"  
R5-1-A 48" x 48"



R5-2 24" x 24"  
24" x 18"

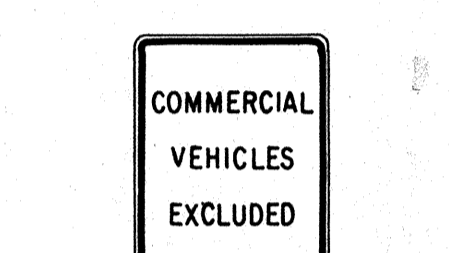

R5-4 24" x 30"



R5-6 24" x 24"  
24" x 18"

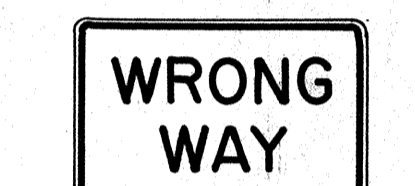

R5-9 36" x 24"

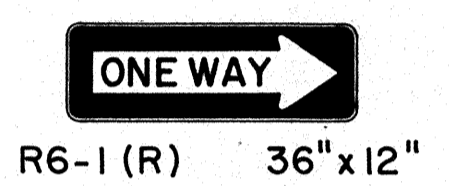

R6-1 (R) 36" x 12"



R6-2(R) 18" x 24"



R7-1 12" x 18"  
R7-1-A 24" x 30"

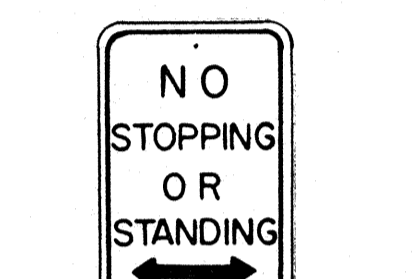

R7-4 12" x 18"  
R7-4-A 24" x 30"



R7-1.7(R) 12" x 18"

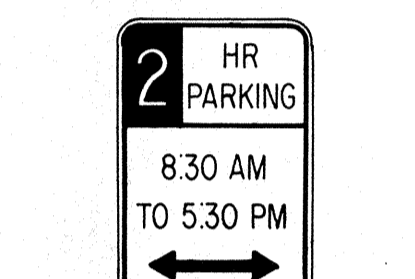

R7-108 12" x 18"

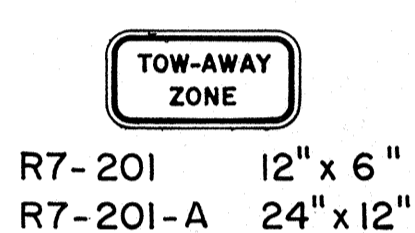

R7-201 12" x 6"  
R7-201-A 24" x 12"



R8-1 24" x 30"



R8-2 24" x 30"



R8-3 24" x 30"



R8-4 30" x 24"  
R8-4-A 48" x 36"



R8-5 24" x 30"



R8-6 24" x 30"



R8-7 30" x 24"  
R8-7-A 48" x 36"

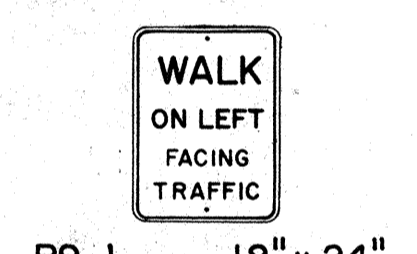

R9-1 18" x 24"



R9-2 12" x 18"



R9-3 12" x 18"



R9-4 18" x 24"

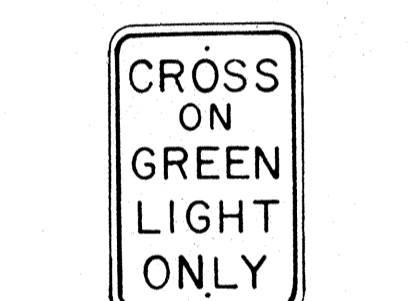

R10-1 12" x 18"



R10-2 12" x 18"

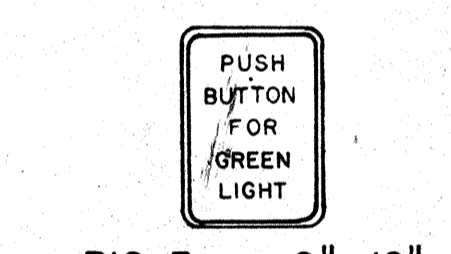

R10-3 9" x 12"

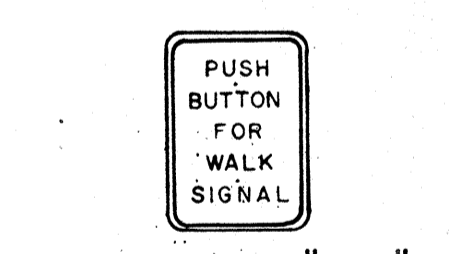

R10-4 9" x 12"

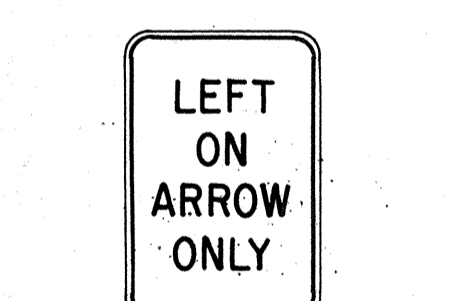

R10-5 24" x 30"



R10-6 24" x 36"

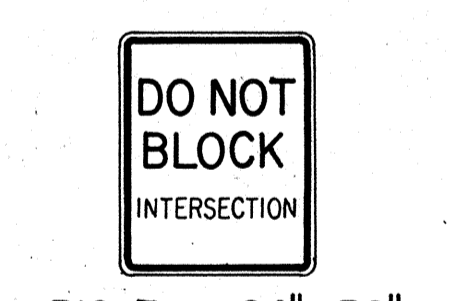

R10-7 24" x 30"



R10-8 24" x 30"

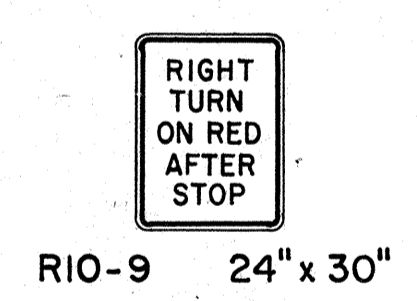

R10-9 24" x 30"

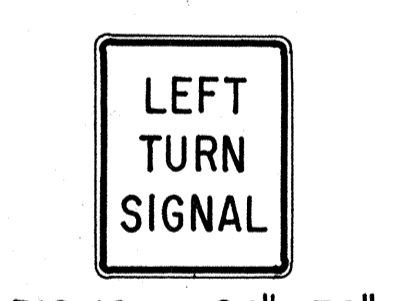

R10-10 24" x 30"

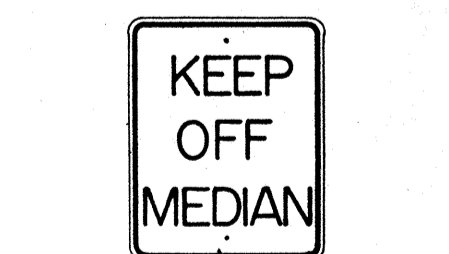

R11-1 24" x 30"



R11-2 48" x 30"

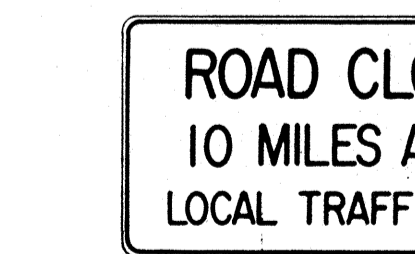

R11-3(10) 60" x 30"

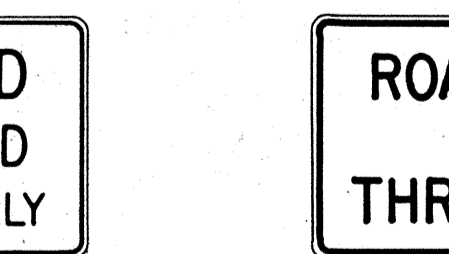

R11-4 60" x 30"



R12-1(10) 24" x 30"

**GENERAL NOTES**

1. Sign details shall conform to the FHWA publications "Manual on Uniform Traffic Control Devices for Streets and Highways," 1971, and "Standard Highway Signs," 1972, and as amended.
2. All regulatory signs shall be reflectorized unless otherwise specified.
3. All regulatory signs shall have 3/8" bolt holes drilled at appropriate locations.
4. Numerals in ( ) indicates numerals to be inserted for sign message. (R) or (L) indicates right or left.
5. All signs shall be erected without educational plaques unless called for in the plans.

APPROVAL RECOMMENDED:  
*Etsuki Tanaka* 3/11/72  
TRAFFIC ENGINEER DATE

APPROVED:  
*Robert Robinson* 3-20-72  
ASSISTANT CHIEF, ENGINEERING DATE

NO.	REVISION	APPROVED BY	DATE
1	Supersedes Sht. DT 101 Approved 12-30-69	H.T.	3/20/72
2	Revised General Note 1.	H.T.	10/16/74
3	Added General Note 5	H.T.	8/7/79

STATE OF HAWAII  
DEPARTMENT OF TRANSPORTATION  
HIGHWAYS DIVISION

**STANDARD DETAILS**  
**REGULATORY SIGNS**

NOT TO SCALE

DATE: \_\_\_\_\_  
SURVEY PLOTTED BY: \_\_\_\_\_  
DESIGNED BY: \_\_\_\_\_  
NOTE BOOK: \_\_\_\_\_  
QUANTITIES BY: \_\_\_\_\_  
CHECKED BY: \_\_\_\_\_

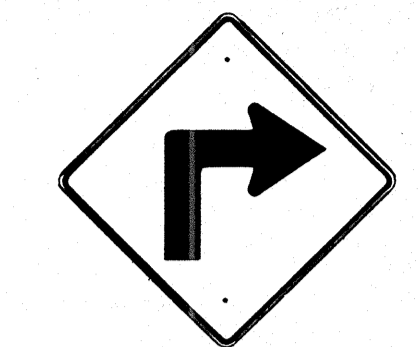

W1-1(R) 30"x30"  
W1-1(R)-A 48"x48"

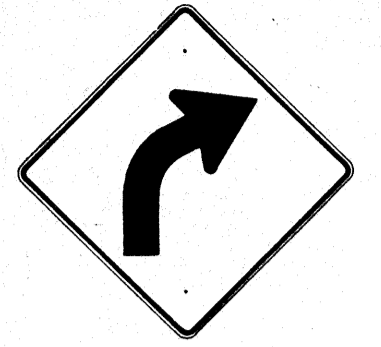

W1-2(R) 30"x30"  
W1-2(R)-A 48"x48"

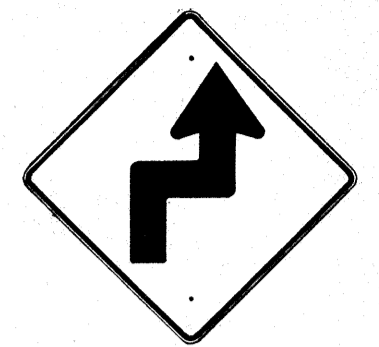

W1-3(R) 30"x30"  
W1-3(R)-A 48"x48"

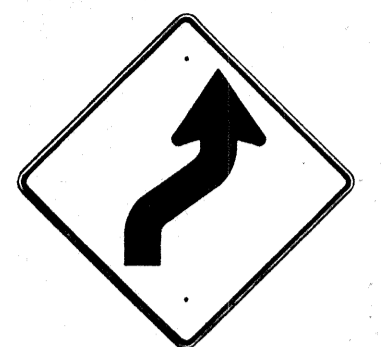

W1-4(R) 30"x30"  
W1-4(R)-A 48"x48"



W1-5(R) 30"x30"  
W1-5(R)-A 48"x48"

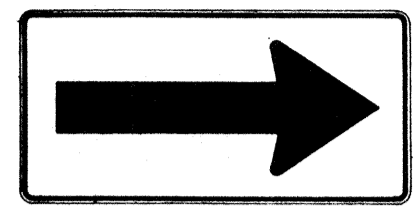

W1-6 48"x24"

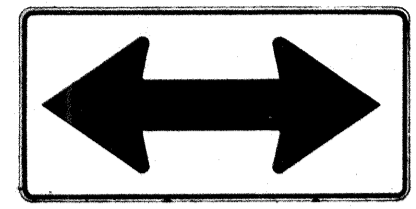

W1-7 48"x24"

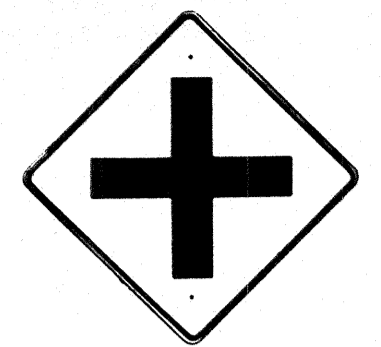

W2-1 30"x30"  
W2-1-A 48"x48"

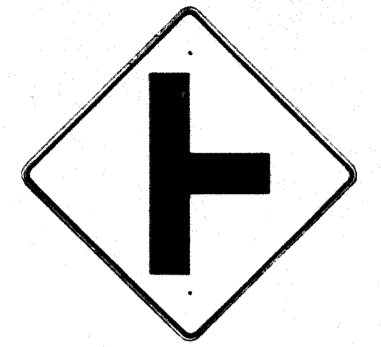

W2-2 30"x30"  
W2-2-A 48"x48"

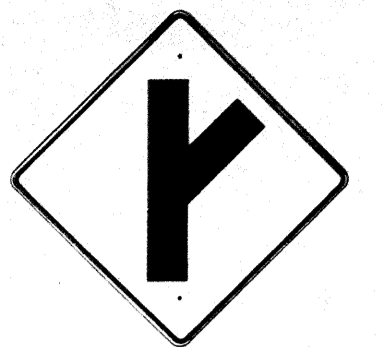

W2-3(R) 30"x30"  
W2-3(R)-A 48"x48"

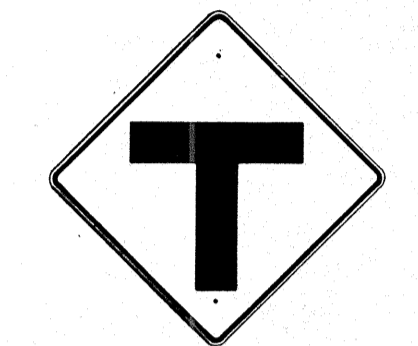

W2-4 30"x30"  
W2-4-A 48"x48"



W2-5 30"x30"  
W2-5-A 48"x48"



W3-1 30"x30"  
W3-1-A 36"x36"



W3-2 30"x30"  
W3-2-A 36"x36"

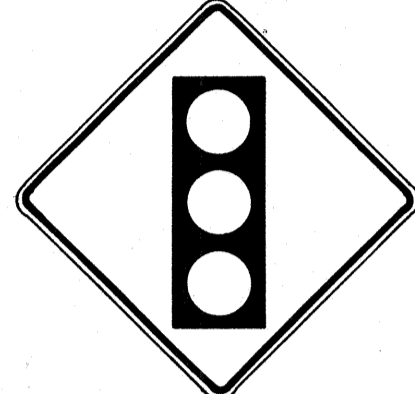

W3-3 36"x36"  
24"x18"



W4-1(R) 30"x30"  
24"x18"  
W4-1(R)-A 48"x48"  
24"x18"

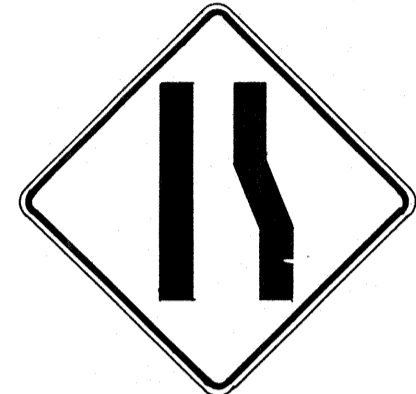

W4-2(R) 36"x36"  
W4-2(R)-A 48"x48"



W5-1 36"x36"



W5-2 30"x30"  
W5-2-A 36"x36"



W5-3 36"x36"



W6-1 36"x36"  
24"x18"



W6-2 36"x36"  
24"x18"

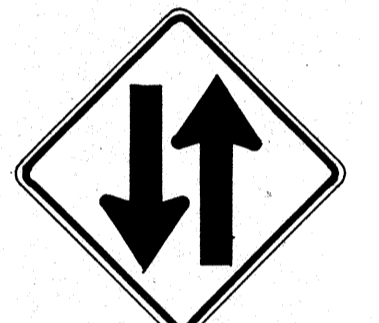

W6-3 30"x30"  
24"x18"  
W6-3-A 36"x36"  
24"x18"  
W6-3-B 48"x48"  
24"x18"



W7-1 30"x30"  
24"x18"  
W7-1-A 36"x36"  
24"x18"



W7-2 24"x18"



W8-1 30"x30"  
W8-1-A 36"x36"



W8-2 30"x30"  
W8-2-A 36"x36"



W8-3 30"x30"  
W8-3-A 36"x36"



W8-4 30"x30"  
W8-4-A 36"x36"



W8-5 30"x30"  
24"x18"  
W8-5-A 36"x36"  
24"x18"



W9-1(R) 30"x30"  
W9-1(R)-A 36"x36"  
W9-1(R)-B 48"x48"



W9-2(L) 36"x36"  
W9-2(L)-A 48"x48"



W10-1 36" Diameter



W11-1 30"x30"  
24"x18"  
W11-1-A 36"x36"  
24"x18"



W11-2 30"x30"  
24"x18"  
W11-2-A 36"x36"  
24"x18"



W11-4 30"x30"  
24"x18"  
W11-4-A 36"x36"  
24"x18"



W11-5 30"x30"  
24"x18"  
W11-5-A 36"x36"  
24"x18"

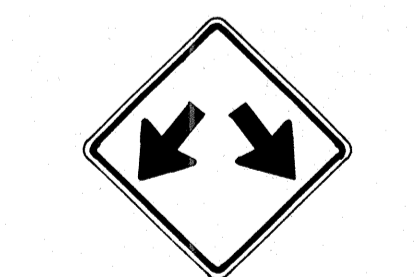

W12-1 24"x24"  
W12-1-A 36"x36"  
W12-1-B 48"x48"



W12-2(12'-6") 36"x36"  
24"x18"



W13-1(25) 18"x18"  
W13-1(25)-A 24"x24"

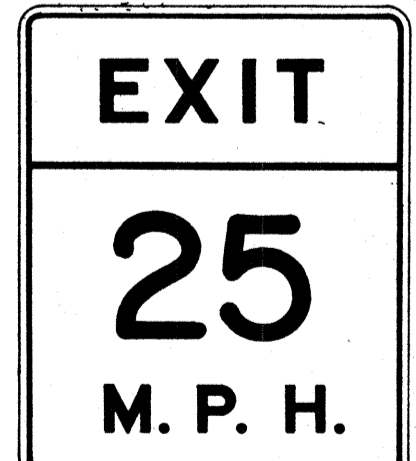

W13-2(25) 48"x60"

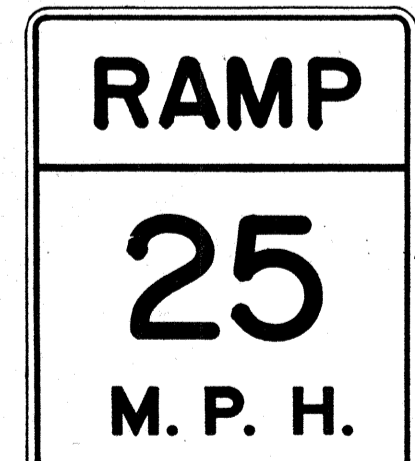

W13-3(25) 48"x60"



W14-1 30"x30"



W14-3 36"x48"x48"

**GENERAL NOTES**

1. Sign details shall conform to the FHWA publications "Manual on Uniform Traffic Control Devices for Streets and Highways," 1971, and "Standard Highway Signs," 1972, and as amended.
2. All warning signs shall be reflectorized unless otherwise specified.
3. All warning signs shall have 3/8" bolt holes drilled at appropriate locations.
4. Numerals in ( ) indicates numerals to be inserted for sign message. (R) or (L) indicates right or left.
5. Signs prefixed with "CW" on the plans shall indicate orange and black construction signs, and shall be reflectorized.

APPROVAL RECOMMENDED:  
*Eishi Tanaka* 3/17/72  
TRAFFIC ENGINEER DATE

APPROVED:  
*Hubert Belsis* 3-20-72  
ASSISTANT CHIEF, ENGINEERING DATE

NO.	REVISION	APPROVED BY	DATE
1	Supersedes Sht. DT 102 Approved 12-30-69	H.T.	3/20/72
2	Revised General Note 1	H.T.	10/16/74
3	Revised General Note 5	MA	9-16-75
4	Revised General Note 5	H.T.	9-14-76
5	Added Note 1	H.T.	11-7-79

STATE OF HAWAII  
DEPARTMENT OF TRANSPORTATION  
HIGHWAYS DIVISION

**STANDARD DETAILS**  
**WARNING SIGNS**

NOT TO SCALE

SHEET No. P-11 OF P-17 SHEETS DT 102

NOTE  
1. All signs shall be erected without educational plaques unless called for in the plans.

DATE  
SURVEY PLOTTED BY  
DRAWN BY  
DESIGNED BY  
NOTE BOOK  
QUANTITIES BY  
CHECKED BY  
No.

General Notes

- Sign details shall conform to the latest editions of the following FHWA publications:
  - "Standard Alphabets for Highway Signs," and as amended.
  - "Standard Highway Signs," and as amended.
  - "Manual on Uniform Traffic Control Devices for Streets and Highways," and as amended.
- All signs shall be reflectorized with reflective sheeting, unless otherwise specified.
- All signs shall have  $\frac{3}{8}$ " bolt holes drilled at appropriate locations.
- Numerals in ( ) indicate numerals to be inserted for sign message. (R) or (L) indicates right or left.
- Signs prefixed with "CW" on the plans shall indicate orange and black construction signs, and shall be reflectorized with reflective sheeting.
- All signs shall be erected without educational plaques unless called for in the plans.

ALL WAY  
R1-4 18" x 6"

REDUCED SPEED  
35  
AHEAD  
R2-5d(35) 24" x 30"  
R2-5d(35)-A 48" x 60"

SPEED LIMIT ENFORCED BY VASCAR  
4" Series D  
- 4" Series C  
- 3" Series D  
- 5" Series C  
R2-10 24" x 30"

CENTER LANE ONLY  
R3-9b 24" x 36"

BUS STOP  
R7-107(R) 12" x 24"

RESERVED PARKING  
R7-8 12" x 18"  
R7-8-A 24" x 30"

ANY TIME  
R8-3a 24" x 24"  
24" x 18"  
R8-3a-A 48" x 48"

NO PED XING  
R9-3a 18" x 18"  
18" x 12"  
R9-3a-A 24" x 24"  
24" x 18"

USE CROSSWALK  
R9-3b(R) 18" x 12"

USE CROSSWALK  
R9-3b(L) 18" x 12"

NO TURN ON RED  
R10-11a 24" x 30"

TURN RIGHT ANY TIME WITH CAUTION  
4" Series C  
R16-1 24" x 30"

NO LEFT TURN ON RED  
4" Series D -  
3" Series D -  
2" Series D -  
3" Series D -  
R16-3 18" x 24"

NO RIGHT TURN ON RED  
R16-4 18" x 24"

UNLICENSED VEHICLES BICYCLES, CYCLES UNDER 5 H.P., PEDESTRIANS KEEP OUT FREEWAY  
3" Series C  
4" Series E  
R16-5 36" x 42"

TURN AHEAD  
8" Series F  
5" Series D  
R16-6 24" x 30"

TURN OK  
8" Series F  
5" Series D  
R16-7 24" x 30"

MOTOR-DRIVEN CYCLES PROHIBITED  
4" Series B  
R5-8 30" x 24"

U TURN AHEAD  
W17-1(L) 60" x 60"

STOP AHEAD  
W3-1a 36" x 36"  
24" x 18"  
W3-1a-A 48" x 48"  
24" x 18"

YIELD AHEAD  
W3-2a 36" x 36"  
24" x 18"  
W3-2a-A 48" x 48"  
24" x 18"

STOP AHEAD WHEN FLASHING  
6" Series C  
W3-4 48" x 48"

TRUCK CROSSING  
W8-6 30" x 30"  
W8-6-A 36" x 36"

THRU TRAFFIC MERGE LEFT  
6" Series E  
W9-3(L) 48" x 48"

EQUESTRIAN XING  
W11-7 36" x 36"  
24" x 18"  
W11-7-A 48" x 48"  
24" x 18"

FIRE STATION  
W11-8 36" x 36"  
24" x 18"  
W11-8-A 48" x 48"  
24" x 18"

W11-9 36" x 36"  
W11-9-A 48" x 48"

LIMITED SIGHT DISTANCE  
W14-4 36" x 36"  
W14-4-A 48" x 48"

DELAYED GREEN  
4" Series C  
W15-1 24" x 24"

ADVANCE GREEN  
W15-2 24" x 24"

END FREEWAY  
1/2 MI  
8" Series E  
CW16-1(1/2) 60" x 60"

RIGHT LANE EXIT ONLY  
8" Series E  
W18-1 48" x 60"

SCHOOL BUS STOP AHEAD  
SI-1 36" x 36"

S2-1 36" x 36"

SCHOOL BUS STOP AHEAD  
S3-1 30" x 30"

8:00 AM TO 3:30 PM  
S4-1 24" x 10"  
WHEN CHILDREN ARE PRESENT  
S4-2 24" x 10"

SCHOOL  
S4-3 24" x 8"  
WHEN FLASHING  
S4-4 24" x 10"

SIDEWALK CLOSED  
7" Series D  
CW23-4 48" x 48"

USE SIDEWALK  
4" Series C  
R18-1 24" x 18"

APPROVAL RECOMMENDED:  
*Etschi Tanaka* 5/2/78  
TRAFFIC ENGINEER DATE

APPROVED:  
*Robert Z. Zakeich* 5/2/78  
ASSISTANT CHIEF, ENGINEERING DATE

NO.	REVISION	APPROVED BY	DATE
1	Supersedes Sht. DT 103 approved 3/20/72	H.S.	5/2/78
2	Added General Note 6	H.S.	11/9/78

STATE OF HAWAII  
DEPARTMENT OF TRANSPORTATION  
HIGHWAYS DIVISION

**STANDARD DETAILS**

MISCELLANEOUS SIGNS

NOT TO SCALE DATE: MAY, 1978  
SHEET No. P-12 OF P-17 SHEETS DT 103

FED. ROAD DIST. NO.	STATE	FED. AID PROJ. NO.	FISCAL YEAR	SHEET NO.	TOTAL SHEETS
HAWAII	HAW.	I-HH(133)17	1981	46	159



CW20-1a 48" x 48"



CW20-2d 48" x 48"



CW20-3b 48" x 48"



CW20-4d 48" x 48"



CW20-5d(L) 48" x 48"



CW20-7c 48" x 48"

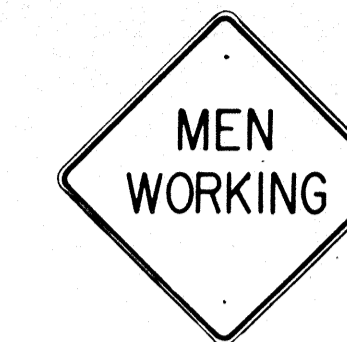

CW21-1 30" x 30"



CW21-2 30" x 30"



CW21-3 36" x 36"



CW21-4 36" x 36"

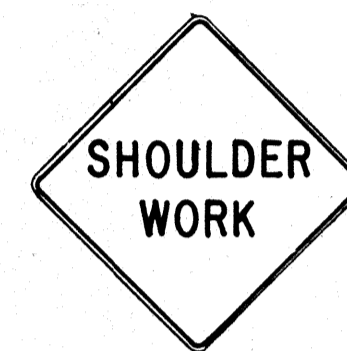

CW21-5 30" x 30"

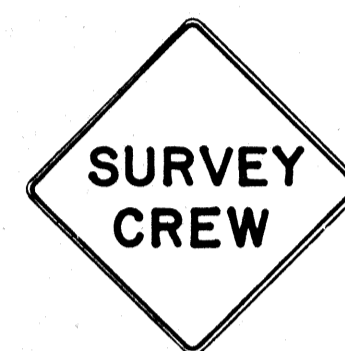

CW21-6 30" x 30"



CW22-1b 48" x 48"



CW22-2 42" x 36"



CW22-3 42" x 36"



CG20-1(5) 60" x 36"

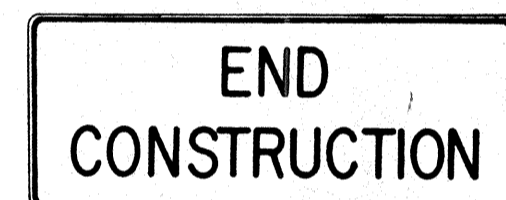

CG20-2 60" x 24"



CM4-9(R) 30" x 24"



CM4-10(R) 48" x 18"

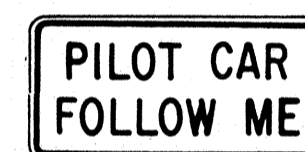

CG20-4 36" x 18"



CW23-1 36" x 36"

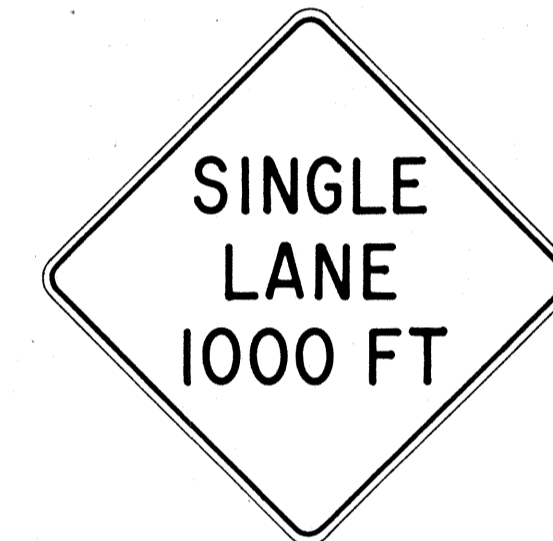

CW23-2b 48" x 48"



CW23-3(R) 48" x 48"

**GENERAL NOTES**

- Sign details shall conform to the FHWA publications "Manual on Uniform Traffic Control Devices for Streets and Highways," 1971, and "Standard Highway Signs," 1972, and as amended.
- All construction signs shall be reflectorized.
- All construction signs shall have 3/8" bolt holes drilled at appropriate locations.
- Numerals in ( ) indicates numerals to be inserted for sign message. (R) or (L) indicates right or left.
- For "CW" series signs, suffixes a,b,c and d are as follows:  
a-1500 FT, b-1000 FT, c-500 FT and d-AHEAD.

APPROVAL RECOMMENDED:  
*Eiichi Tanaka*  
TRAFFIC ENGINEER 3/21/72  
DATE

APPROVED:  
*Muhammad Salsidi*  
ASSISTANT CHIEF, ENGINEERING 3/23/72  
DATE

NO.	REVISION	APPROVED BY	DATE
1	Supersedes Sht. DT 104 Approved 12-30-69	H.T.	3/23/72
2	Revised General Note 1	H.T.	10/16/74
3	Revised General Note 2	MH	9-16-75
4	Revised General Note 2 and sign CG20-1(5)	H.T.	9-14-76

STATE OF HAWAII  
DEPARTMENT OF TRANSPORTATION  
HIGHWAYS DIVISION

**STANDARD DETAILS**  
**CONSTRUCTION SIGNS**

NOT TO SCALE

SURVEY PLOTTED BY: \_\_\_\_\_ DATE: \_\_\_\_\_  
 DRAWN BY: \_\_\_\_\_  
 DESIGNED BY: \_\_\_\_\_  
 NOTE BOOK: \_\_\_\_\_  
 QUANTITIES BY: \_\_\_\_\_  
 CHECKED BY: \_\_\_\_\_  
 No. \_\_\_\_\_

FED. ROAD DIST. NO.	STATE	FED. AID PROJ. NO.	FISCAL YEAR	SHEET NO.	TOTAL SHEETS
HAWAII	HAW.	F-HI-1(133)17	1981	47	159

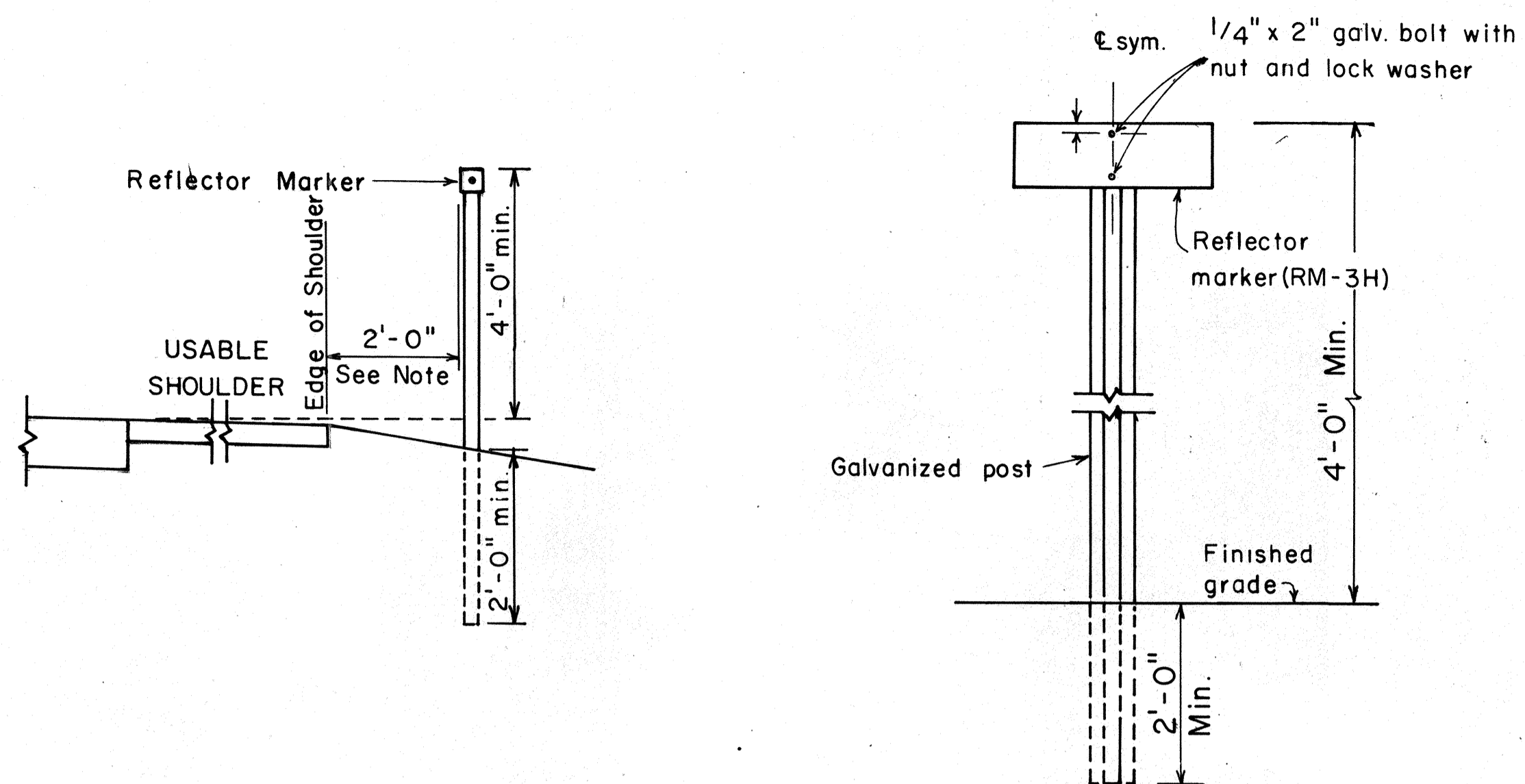

**REFLECTOR MARKER MOUNTING DETAIL**

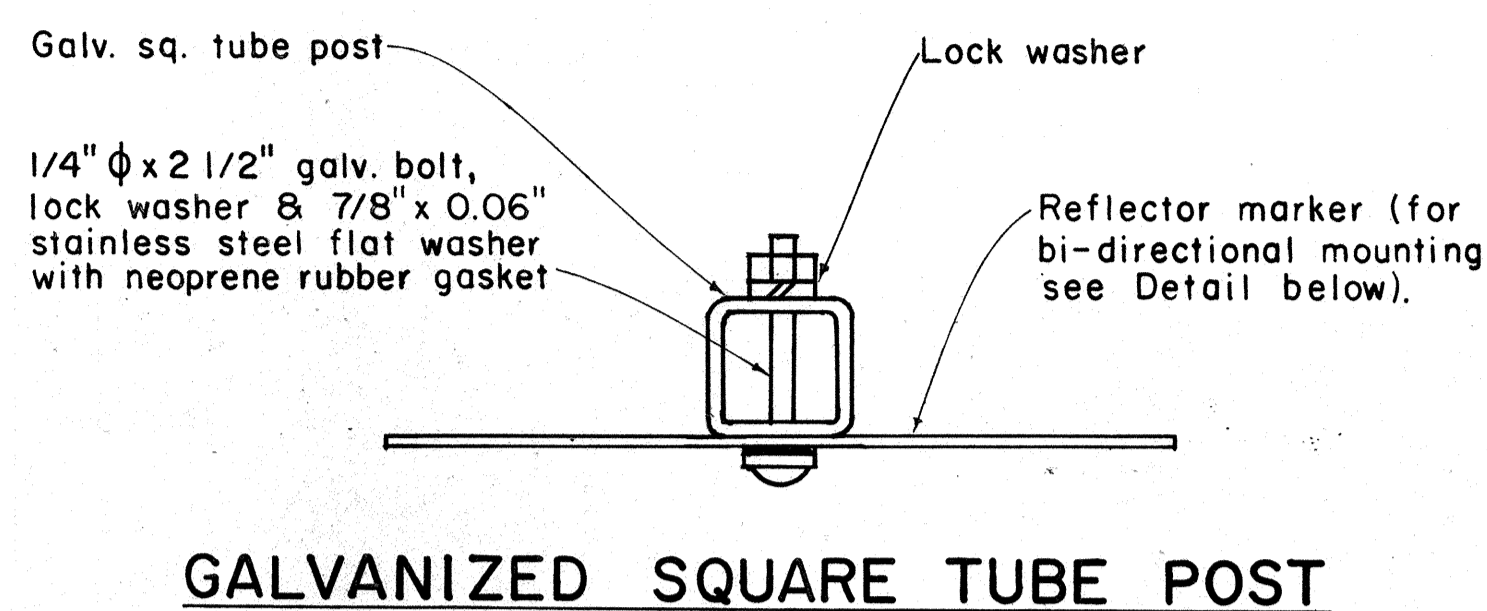

**GALVANIZED SQUARE TUBE POST**

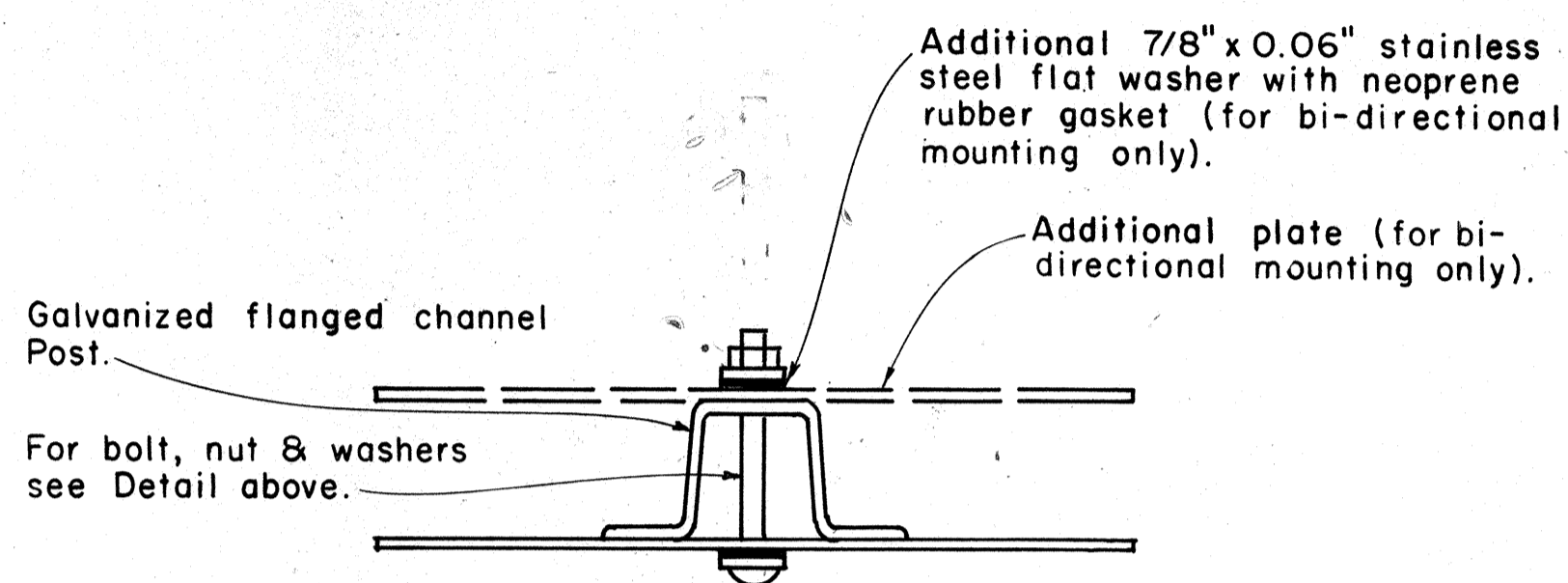

**GALVANIZED FLANGED CHANNEL POST**

**TYPICAL MOUNTING DETAILS**

**GENERAL NOTES:**

1. Clearance markers (RM-3, RM-4) shall be installed with the edge of the marker in line with the inner edge of the obstruction.
2. (R) or (L) indicates right or left and shall be as shown on the plans.
3. Reflector markers RM-1 and RM-2 shall be:
  - a) Yellow if placed along the left edge of divided roadways, one-way roadways, and ramps in the direction of travel.
  - b) White if placed along the right edge of divided roadways, one-way roadways, and ramps in the direction of travel.
4. For reflector marker RM-9, reflective sheeting material may be used as an alternate.
5. For RM-4, the stripes shall slope downward at an angle of 45° in the direction of traffic.

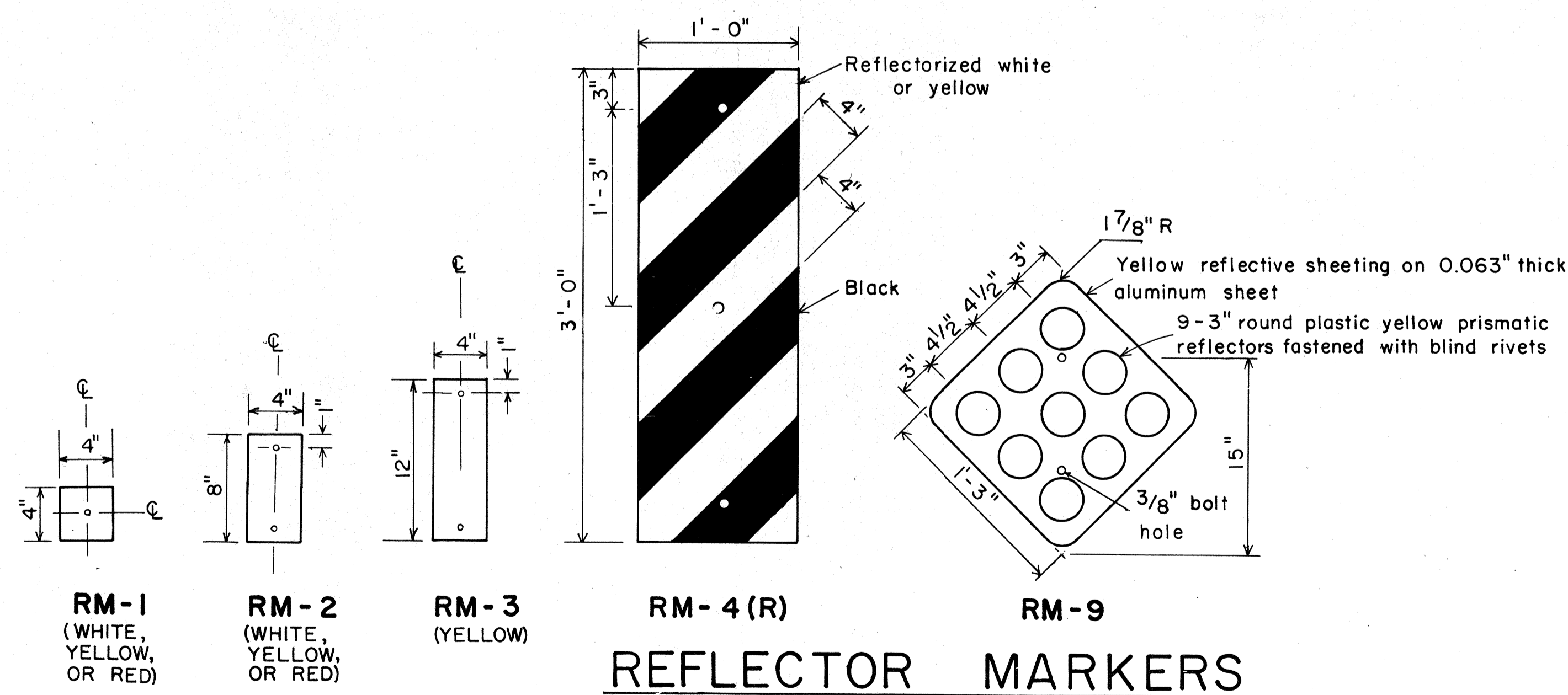

**REFLECTOR MARKERS**

APPROVAL RECOMMENDED:  
*Erich Tanaka* 11/7/77  
 TRAFFIC ENGINEER DATE

APPROVED:  
*Herbert A. Sakai* 11/15/77  
 ASSISTANT CHIEF, ENGINEERING DATE

NO.	REVISION	APPROVED BY	DATE
1	Revised Mounting Details	H.T.	4/23/80

STATE OF HAWAII  
 DEPARTMENT OF TRANSPORTATION  
 HIGHWAYS DIVISION

**STANDARD DETAILS**  
 MISCELLANEOUS REFLECTOR MARKERS

Not to scale June, 1977

FED. ROAD DIST. NO.	STATE	FED. AID PROJ. NO.	FISCAL YEAR	SHEET NO.	TOTAL SHEETS
HAWAII	HAW.	I-HI-(133)17	1981	48	159

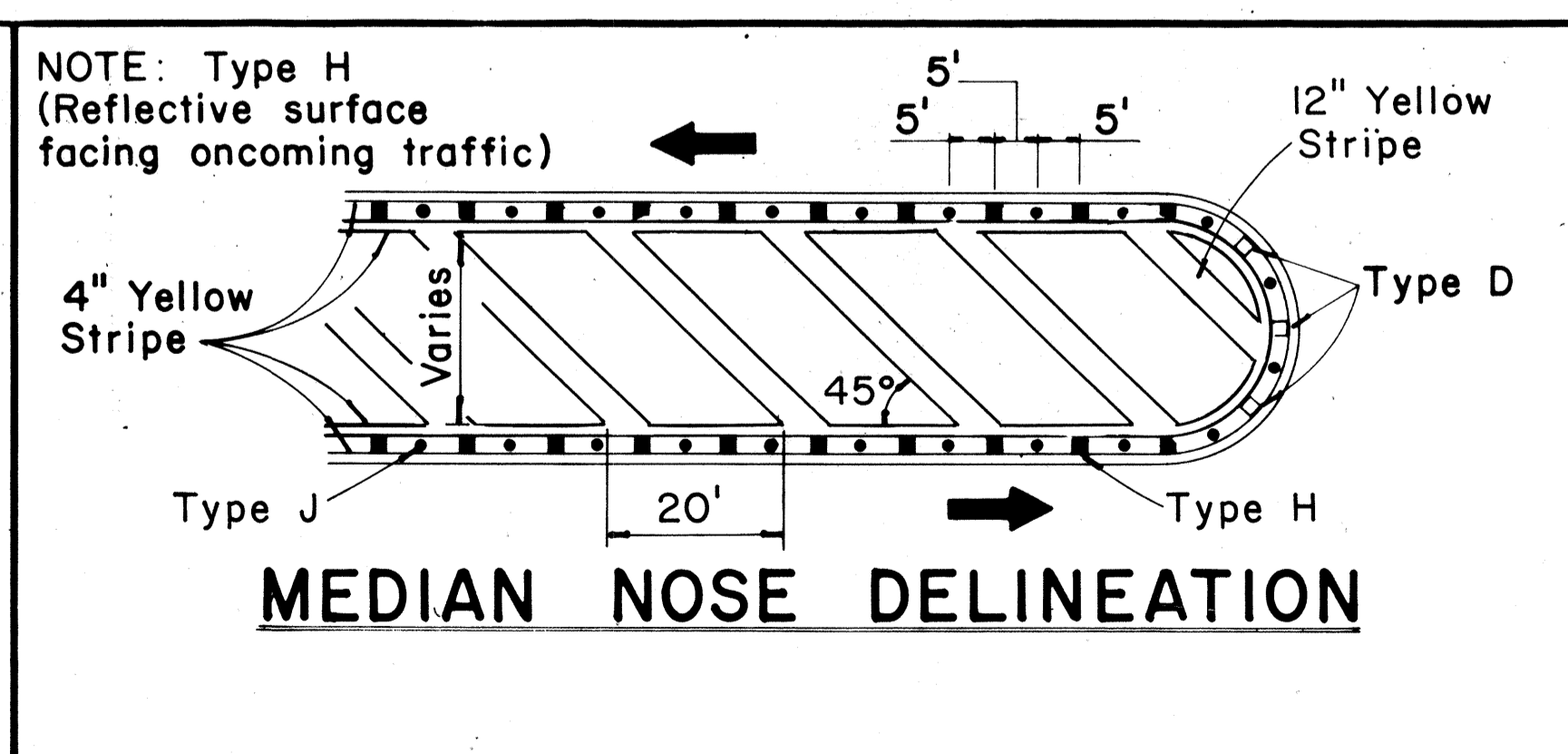
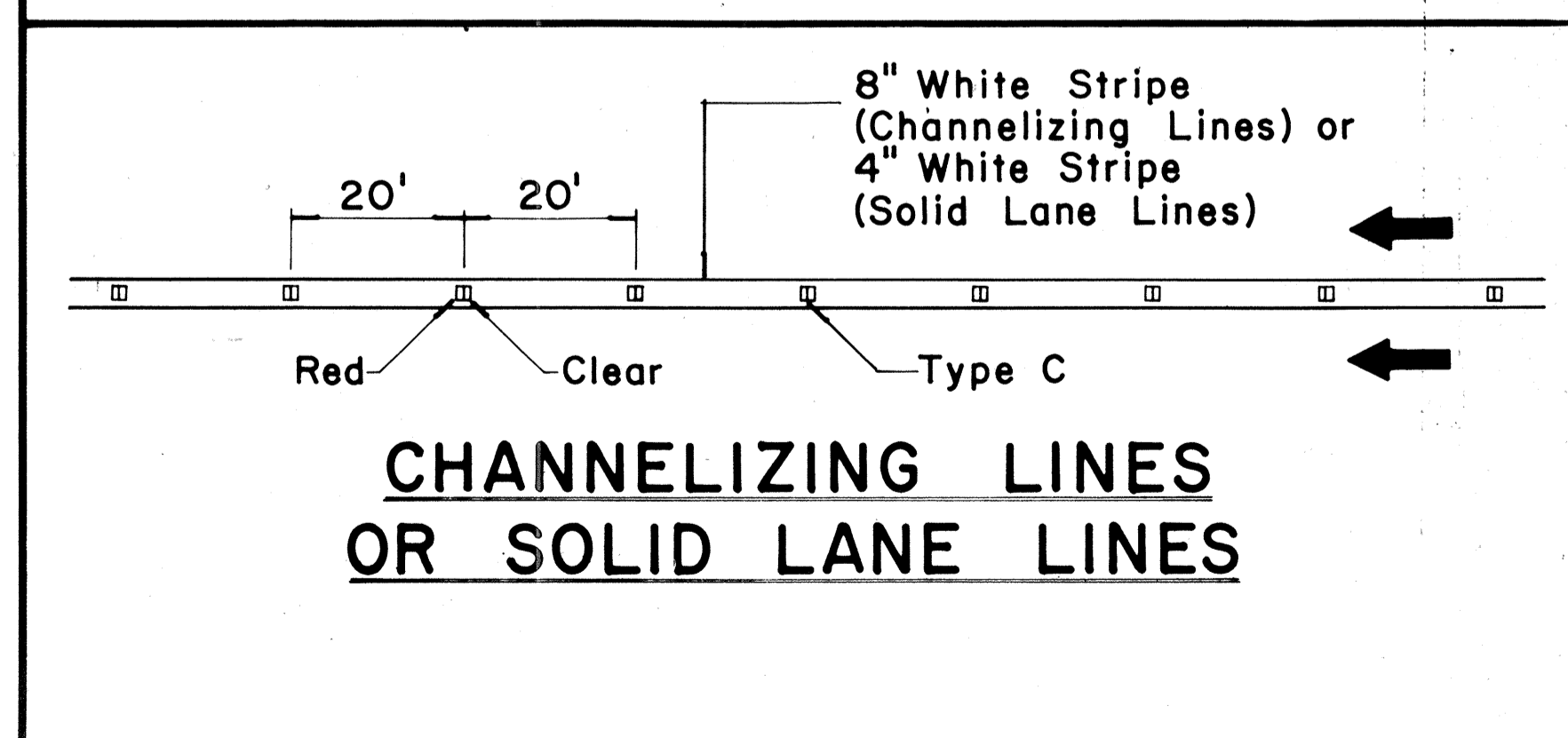
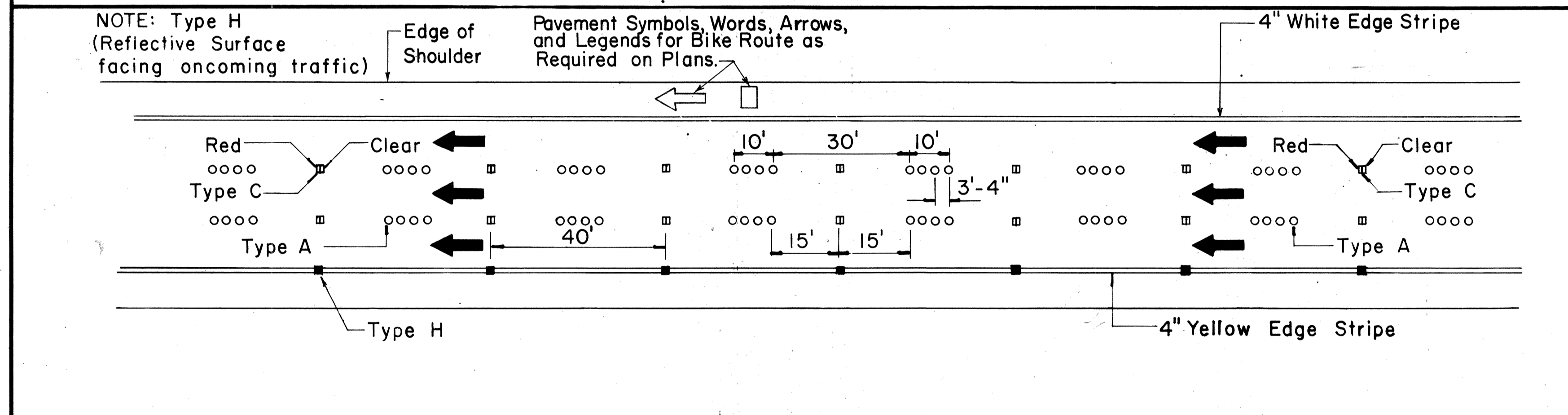
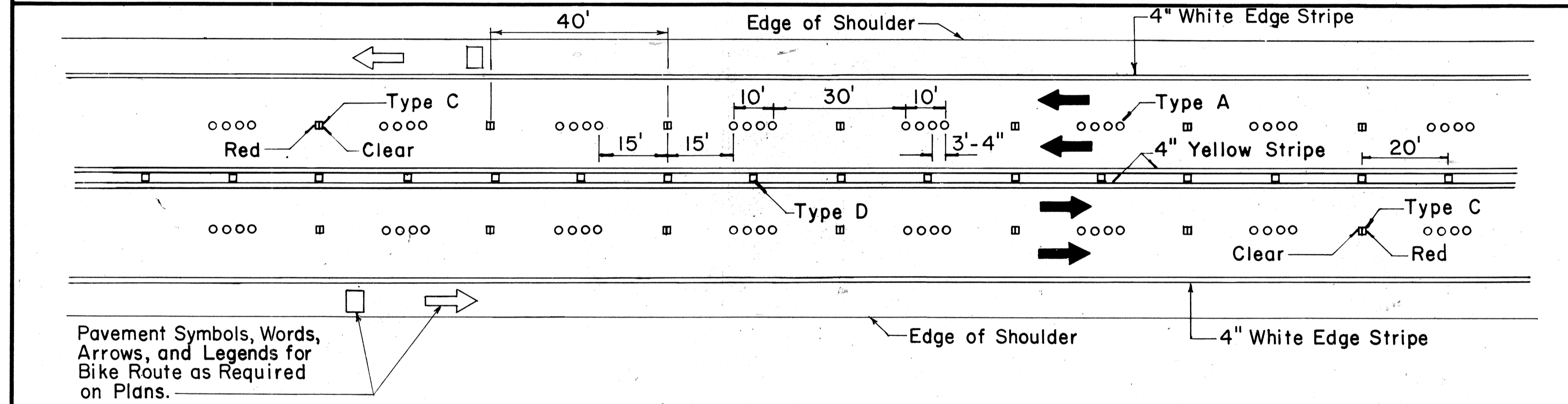
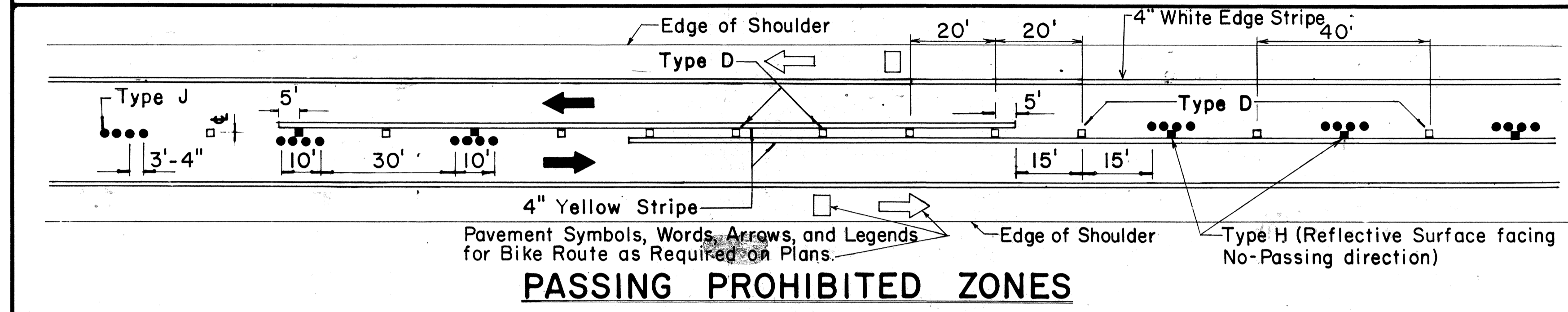
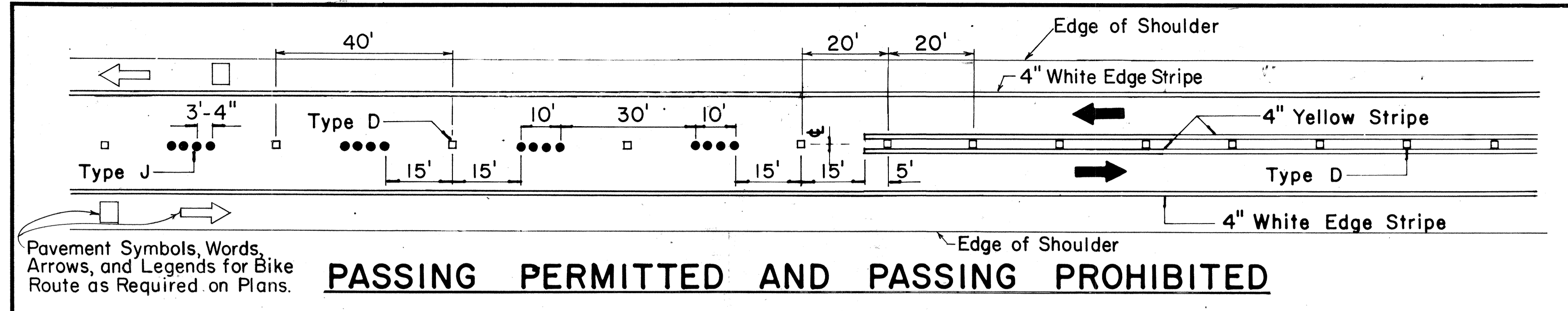

TWO - LANE

MULTI - LANE

DIVIDED HIGHWAY AND FREEWAY

MISCELLANEOUS

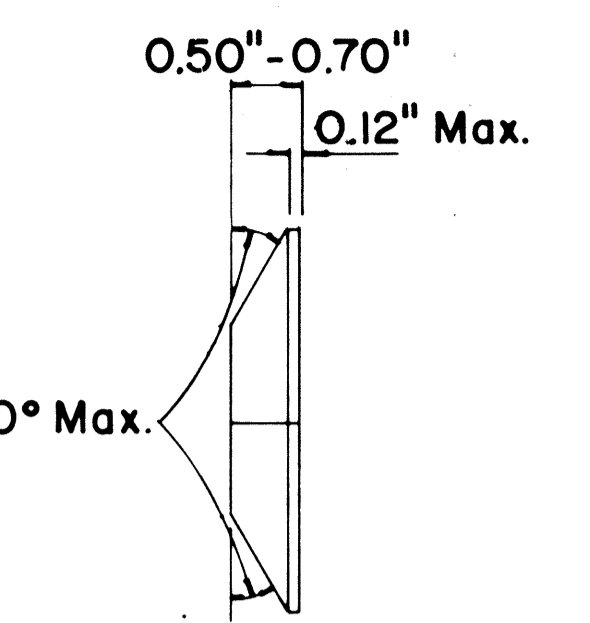
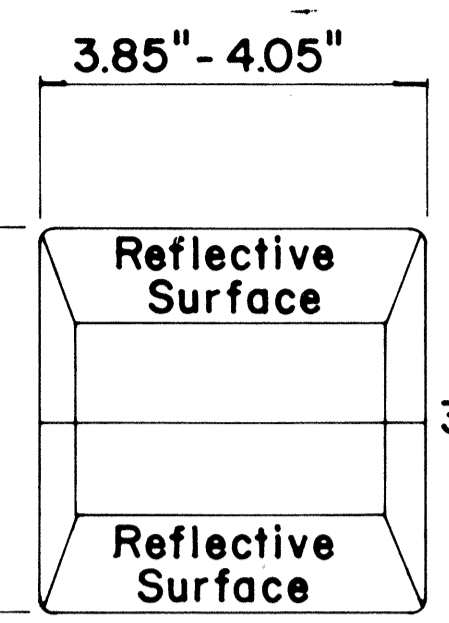
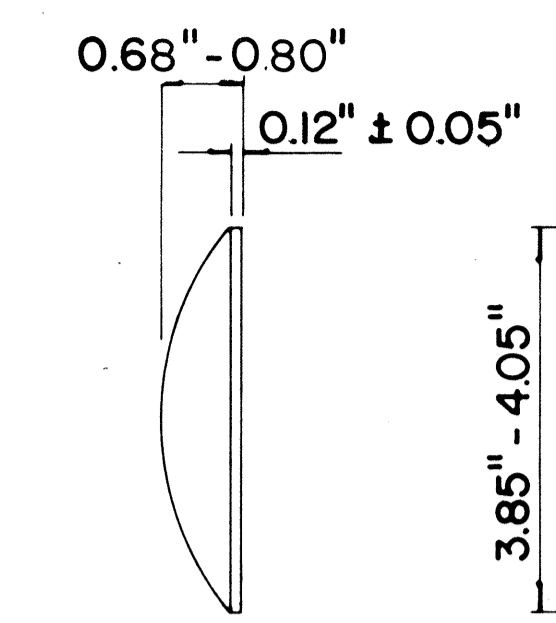
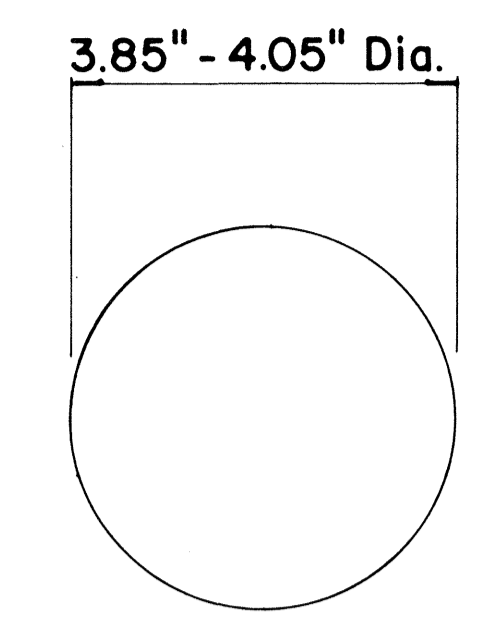

**TYPE A**  
NON-REFLECTIVE WHITE MARKER

**TYPE J**  
NON-REFLECTIVE YELLOW MARKER

**TYPE C**  
RED-CLEAR REFLECTIVE MARKER

**TYPE D**  
TWO-WAY YELLOW REFLECTIVE MARKER

**TYPE H**  
ONE-WAY YELLOW REFLECTIVE MARKER

**GENERAL NOTES**

1. Pavement marking and striping shall conform to the latest "Manual on Uniform Traffic Control Devices for Streets and Highways," and as amended.
2. Layout and installation of pavement marking and striping shall be done by the Contractor. The Contractor shall check the layouts with the Engineer prior to performing work.

**LEGEND**

- Type A
- ◻ Type C
- ◻ Type D
- Type H
- Type J

APPROVAL RECOMMENDED:

*Eiichi Tanaka* 7/21/78  
TRAFFIC ENGINEER DATE

APPROVED:

*Herbert J. Sakai* 7/24/78  
ASSISTANT CHIEF, ENGINEERING DATE

No.	REVISION	APPROVED BY	DATE
1	Supersedes DT 300 approved 11/18/71.	H.C.	7/24/78
2	Delete Type A Markers from Bike Route Delineation.	H.C.	10/15/79

STATE OF HAWAII  
DEPARTMENT OF TRANSPORTATION  
HIGHWAYS DIVISION

**STANDARD DETAILS**  
**RAISED PAVEMENT MARKERS**  
**AND STRIPING**

Not to Scale July 1978  
SHEET No. P-15 OFF-17 SHEETS DT 300

SURVEY PLOTTED BY: \_\_\_\_\_ DATE: \_\_\_\_\_  
 PLAN CHECKED BY: \_\_\_\_\_  
 ORIGINAL PLAN DESIGNED BY: \_\_\_\_\_  
 NOTE BOOK QUANTITIES BY: \_\_\_\_\_  
 CHECKED BY: \_\_\_\_\_

FED. ROAD DIST. NO.	STATE	FED. AID PROJ. NO.	FISCAL YEAR	SHEET NO.	TOTAL SHEETS
HAWAII	HAW.	I-HH(33)17	1981	49	159

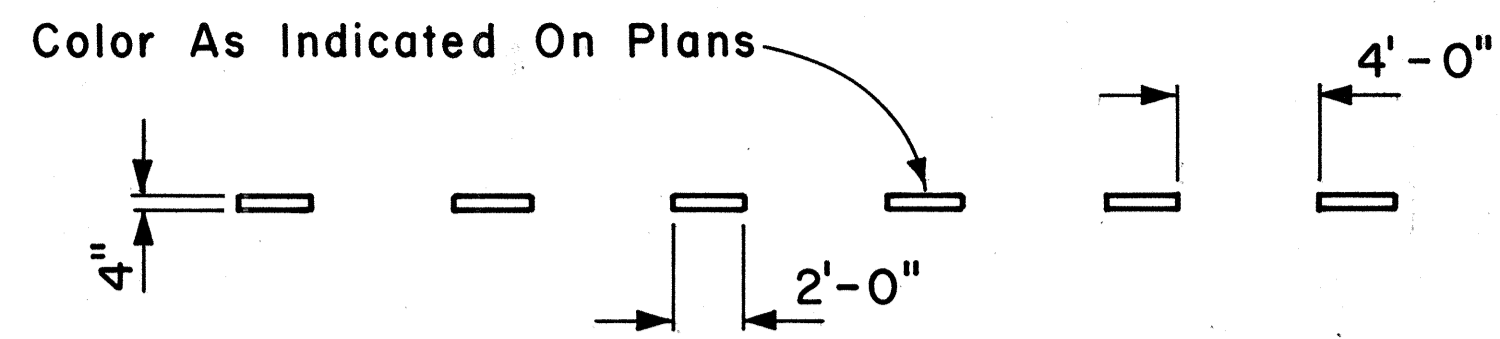

**4" GUIDE LINE**

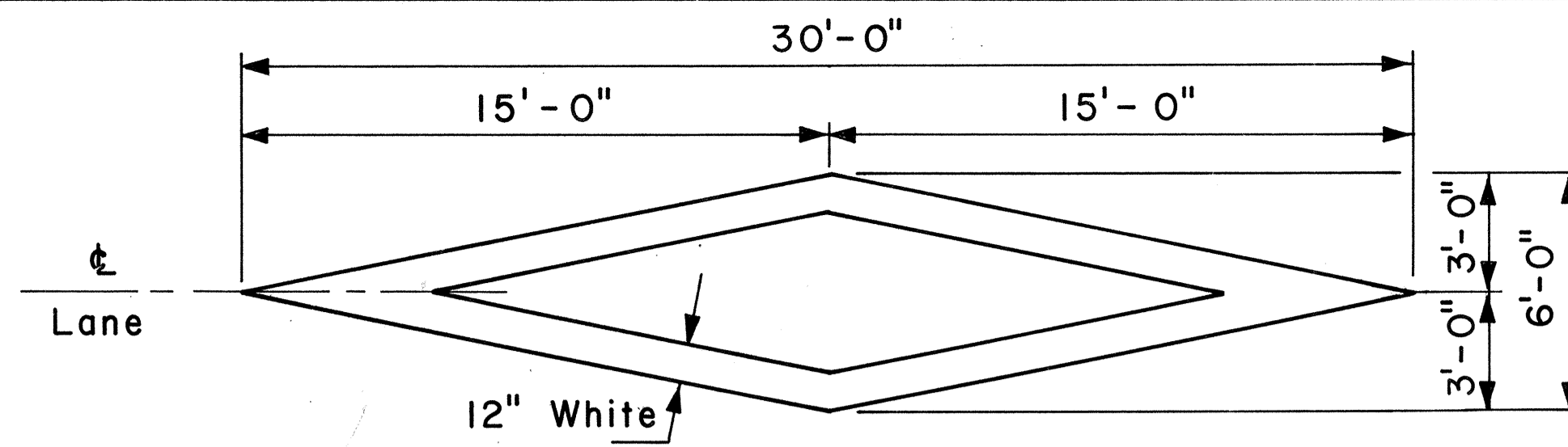

**PAVEMENT DIAMOND**

**GENERAL NOTES:**

1. Pavement marking and striping shall conform to the latest edition of the "Manual on Uniform Traffic Control Devices for Streets and Highways," by the FHWA, and as amended.
2. Layout of pavement markings and striping shall be done by the Contractor. The Contractor shall check layout of markings and striping with the Engineer prior to performing work.
3. For additional pavement marking details, see sheet DT 300.

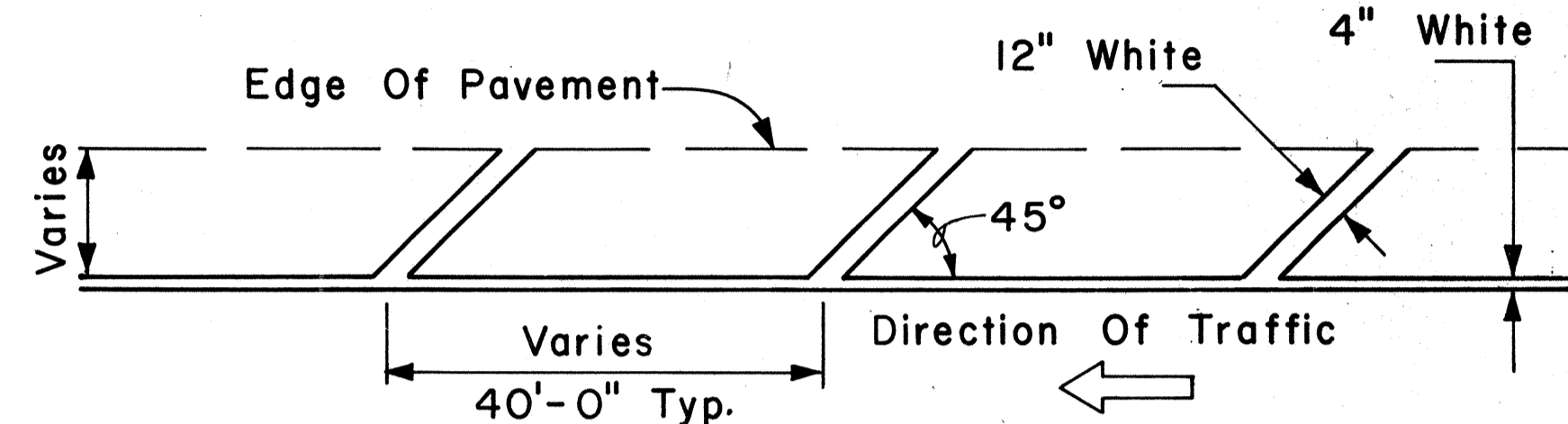

**TRANSVERSE RIGHT SHOULDER MARKING**

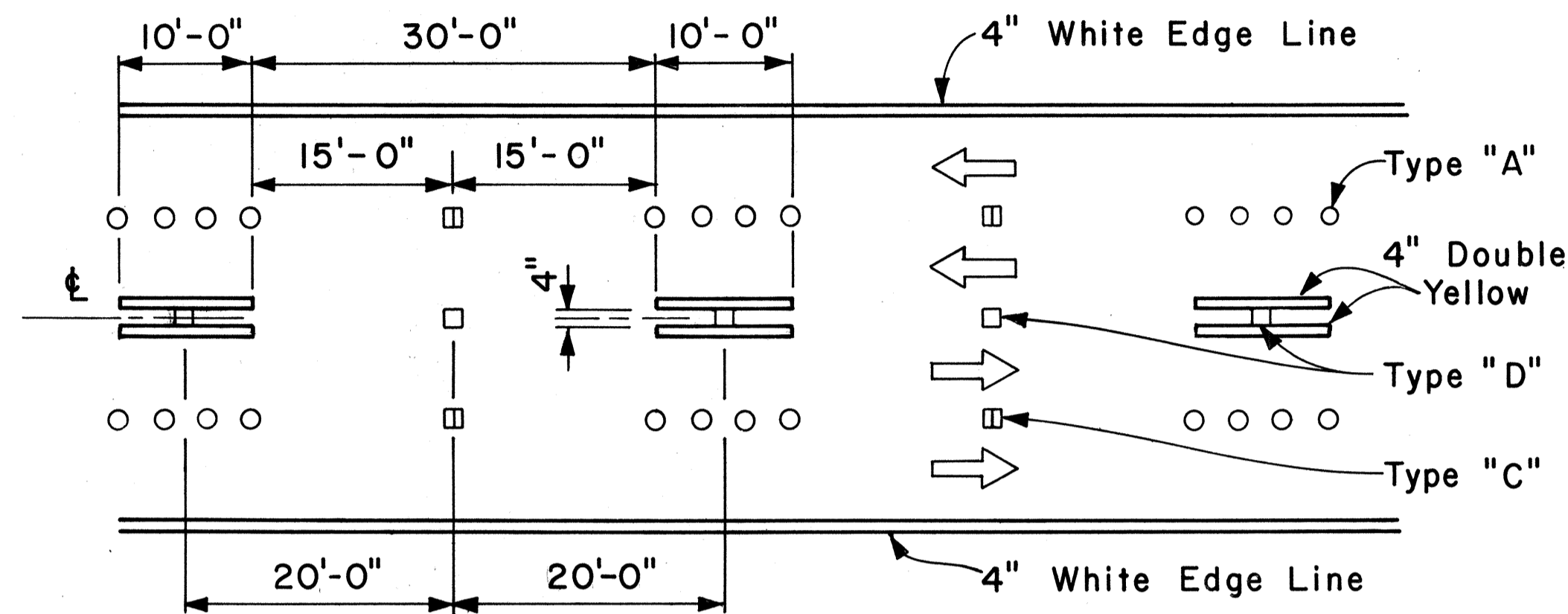

NOTE: Traffic Cone Usage Required.

**MULTI-LANE REVERSIBLE LANES**

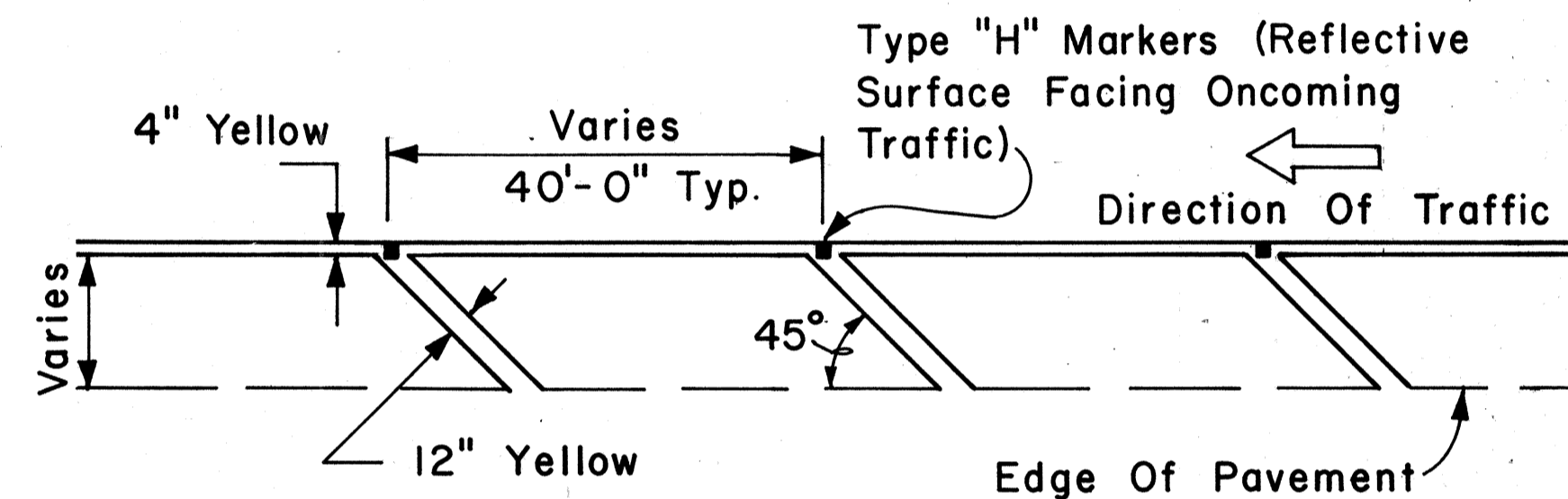

**TRANSVERSE LEFT SHOULDER MARKING**

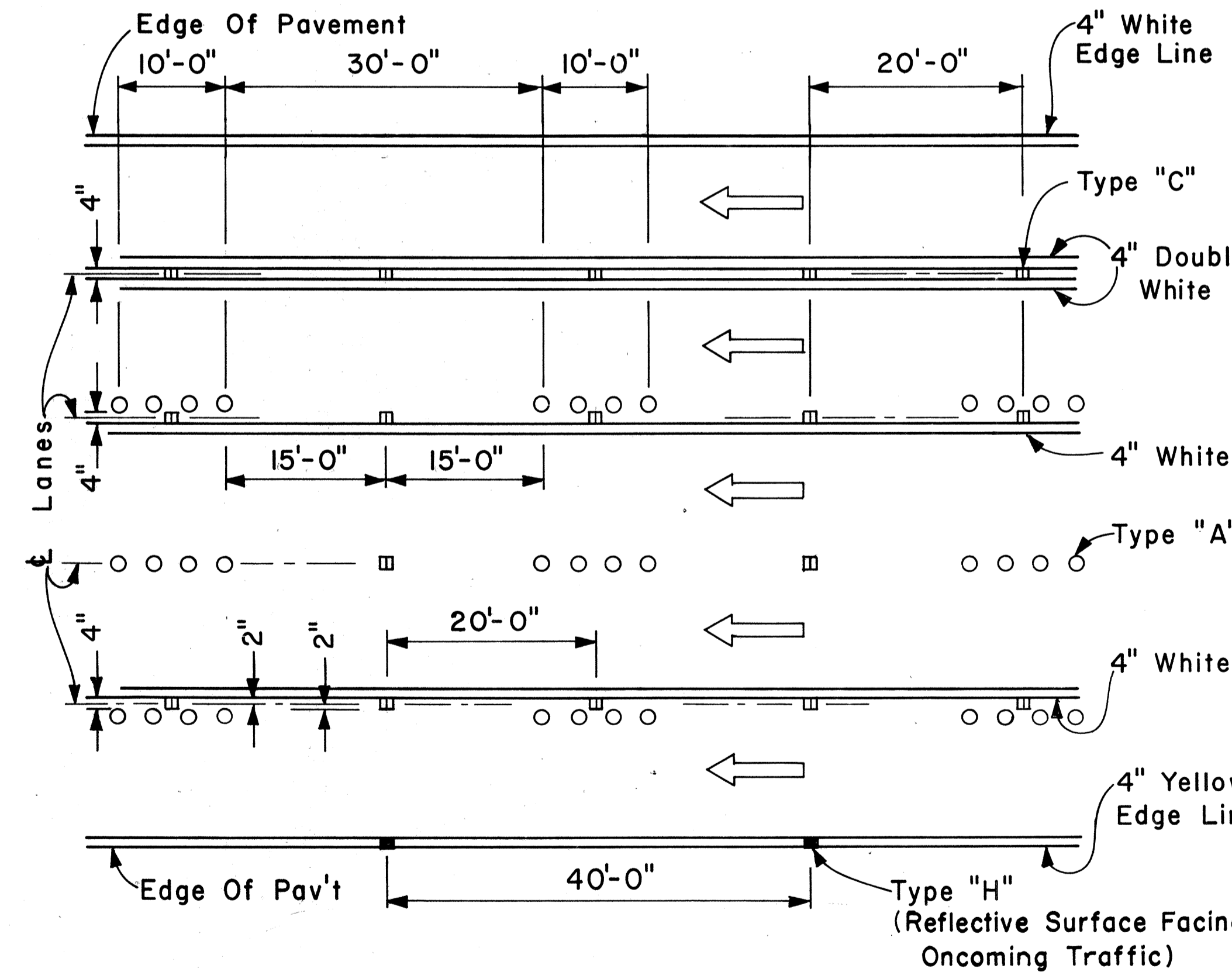

**MULTI-LANE LANE CHANGE RESTRICTION ZONES**

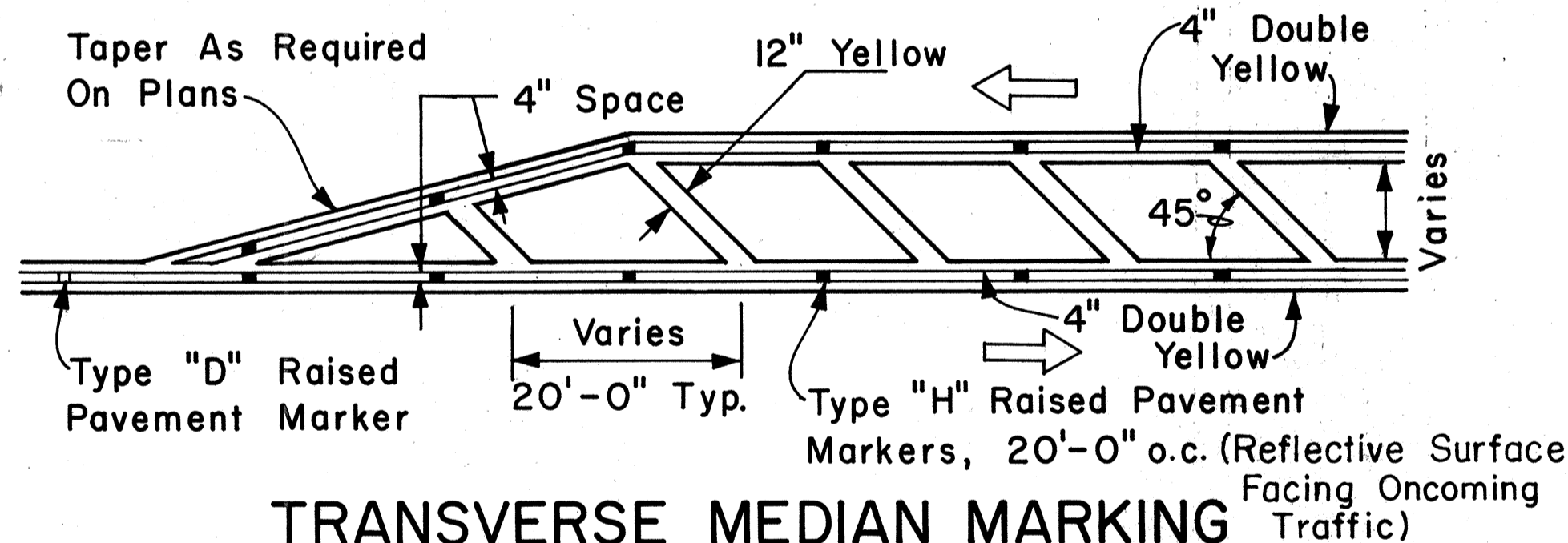

**TRANSVERSE MEDIAN MARKING**

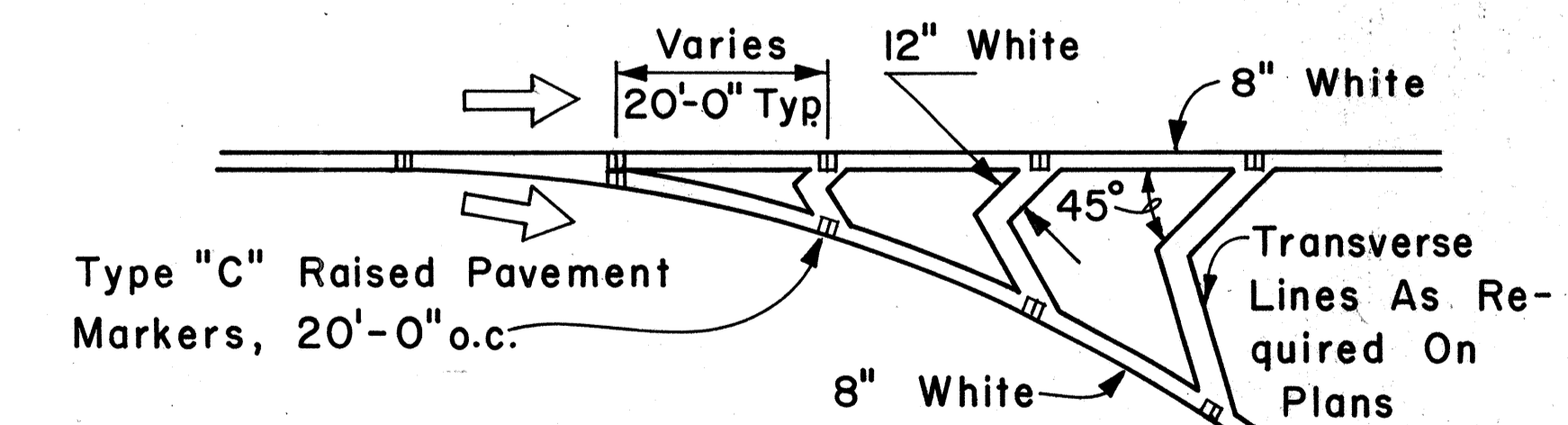

**CHANNELIZING ISLAND**

APPROVAL RECOMMENDED:  
*Eishi Tanaka* 5/2/78  
 TRAFFIC ENGINEER DATE

APPROVED:  
*Harbor 2. Sakai* 5/3/78  
 ASSISTANT CHIEF, ENGINEERING DATE

NO.	REVISION	APPROVED BY	DATE

STATE OF HAWAII  
 DEPARTMENT OF TRANSPORTATION  
 LAND TRANSPORTATION FACILITIES DIVISION  
**STANDARD DETAILS**  
 MISCELLANEOUS  
 PAVEMENT MARKINGS  
 Scale: Not to Scale Date: April, 1978  
 SHEET NO. PIC OF P-17 SHEETS DT 302

FED. ROAD DIST. NO.	STATE	FED. AID PROJ. NO.	FISCAL YEAR	SHEET NO.	TOTAL SHEETS
HAWAII	HAW.	FHH(133)17	1981	50	159

**GENERAL NOTES:**

1. Pavement Markings and Striping shall conform to the latest edition of the "Manual on Uniform Traffic Control Devices for Streets and Highways", by the FHWA, and as amended.
2. Layout of Pavement Markings and Striping shall be done by the Contractor. The Contractor shall check layout of markings and striping with the Engineer prior to performing work.
3. For additional details, see sheet DT 300.

TAPERED DECELERATION LANE

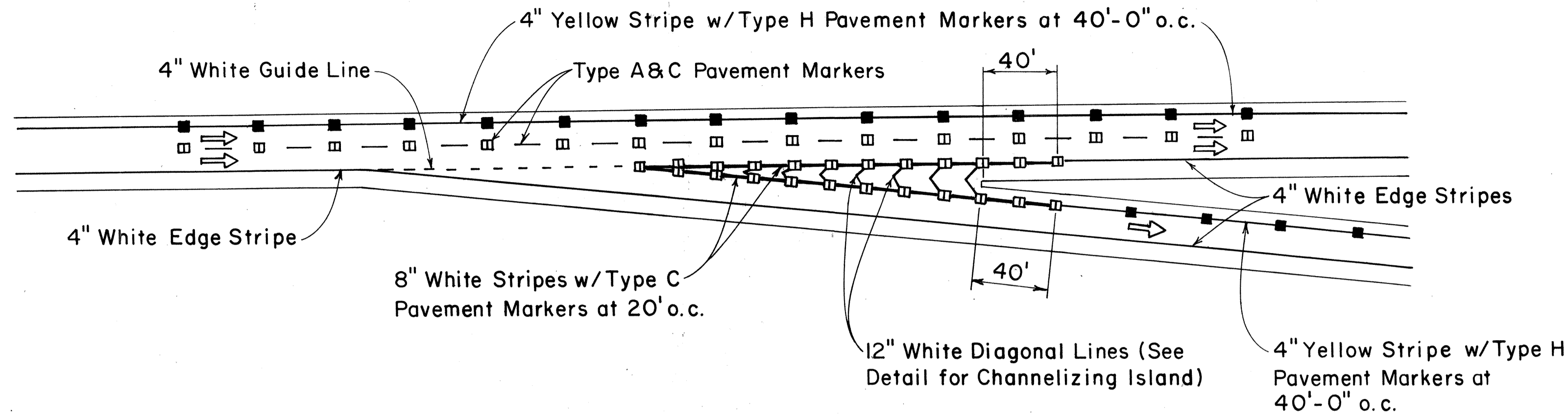

PARALLEL DECELERATION LANE

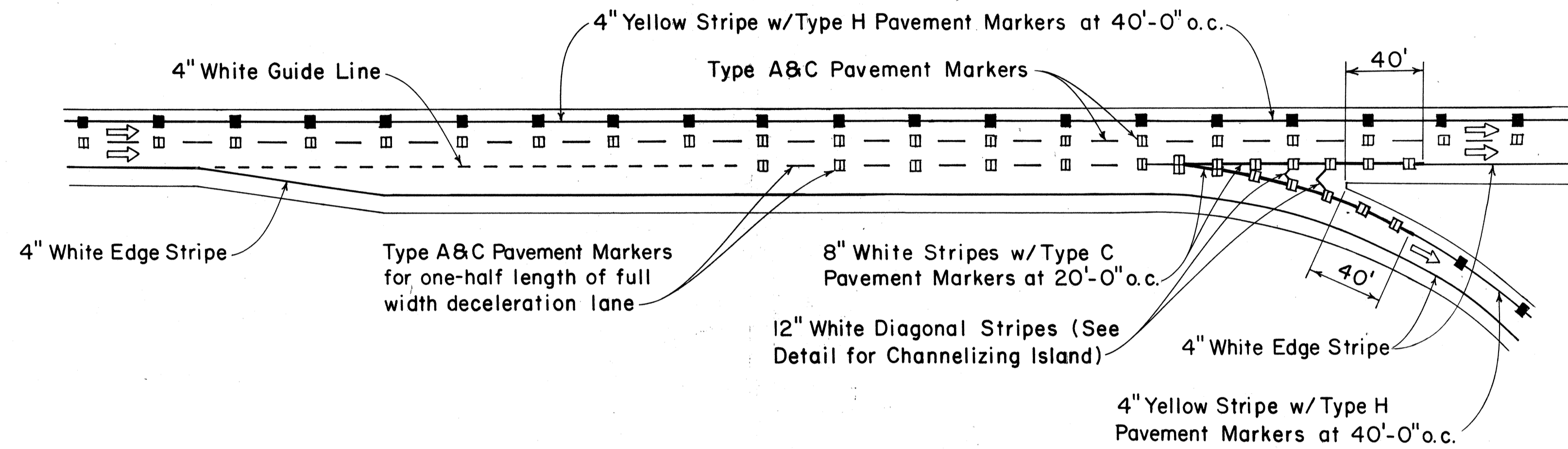

TAPERED ACCELERATION LANE

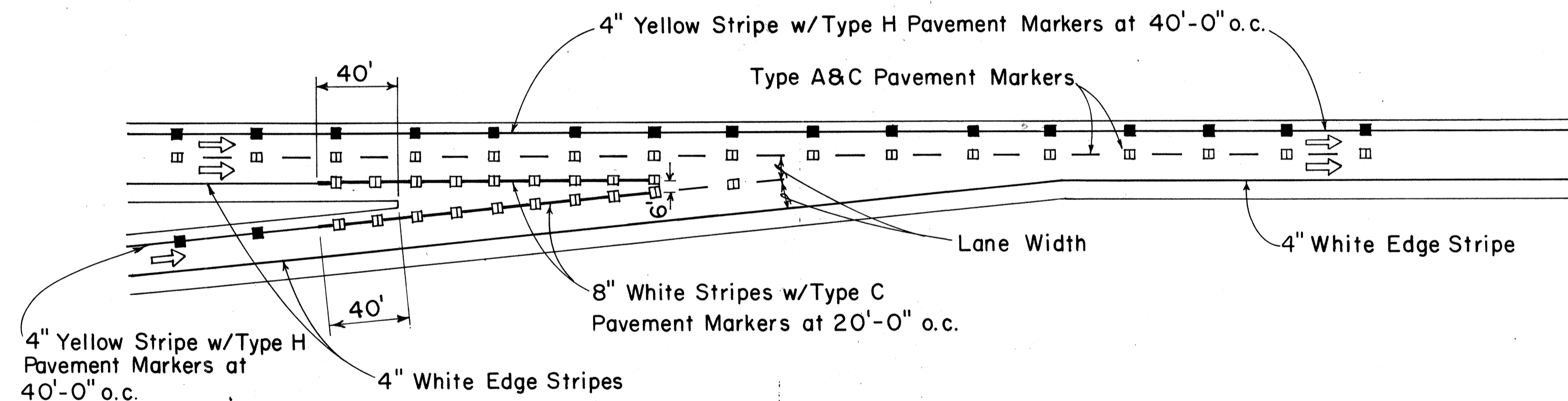

PARALLEL ACCELERATION LANE

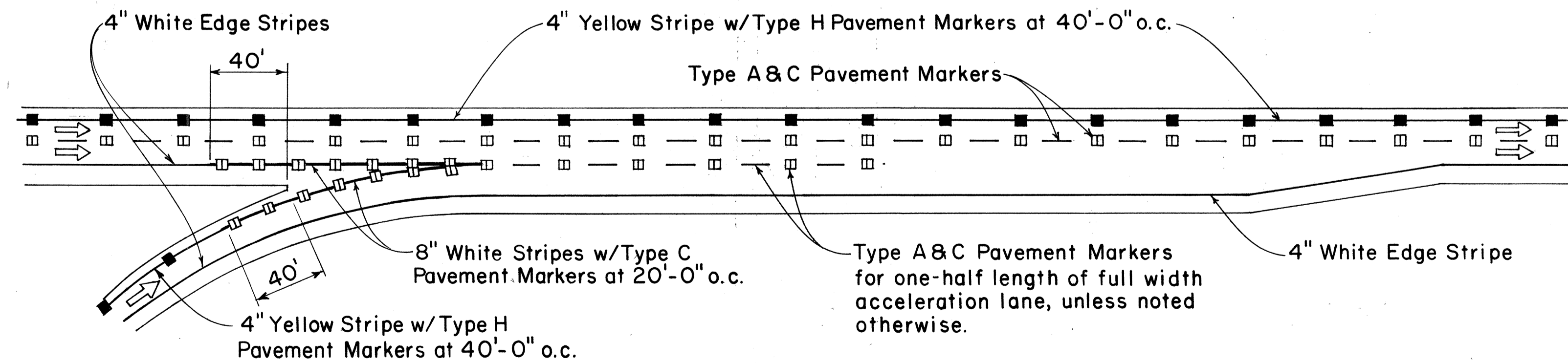

TYPICAL ROADWAY EXIT MARKINGS

TYPICAL ROADWAY ENTRANCE MARKINGS

APPROVAL RECOMMENDED:  
*Eisaki Tanaka* 7/21/78  
 TRAFFIC ENGINEER DATE

APPROVED:  
*Robert D. Rakeishi* 7/24/78  
 ASSISTANT CHIEF, ENGINEERING DATE

NO.	REVISION	APPROVED BY	DATE

STATE OF HAWAII  
 DEPARTMENT OF TRANSPORTATION  
 LAND TRANSPORTATION FACILITIES DIVISION

**STANDARD DETAILS**  
**MISCELLANEOUS**  
**PAVEMENT MARKINGS**

Not to Scale July 1978  
 SHEET NO. R17 OF P17 SHEETS DT 304

ORIGINAL PLAN  
 SURVEY PLOTTED BY  
 DRAWN BY  
 TRACED BY  
 NOTE BOOK DESIGNED BY  
 QUANTITIES BY  
 CHECKED BY  
 No.