

FED. ROAD DIST. NO.	STATE	FED-AID PROJ. NO.	FISCAL YEAR	SHEET NO.	TOTAL SHEETS
HAWAII	HAW.	NH-H1-1(279)	2021	142	304

PAVEMENT MARKING LEGEND:

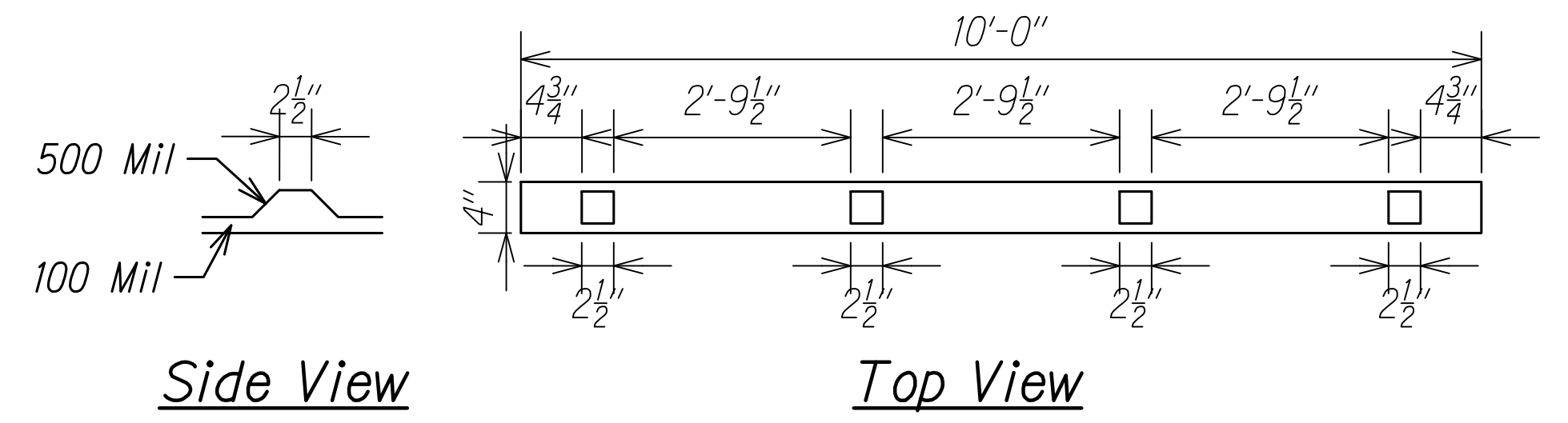

PROFILED THERMOPLASTIC STRIPING
Not to Scale

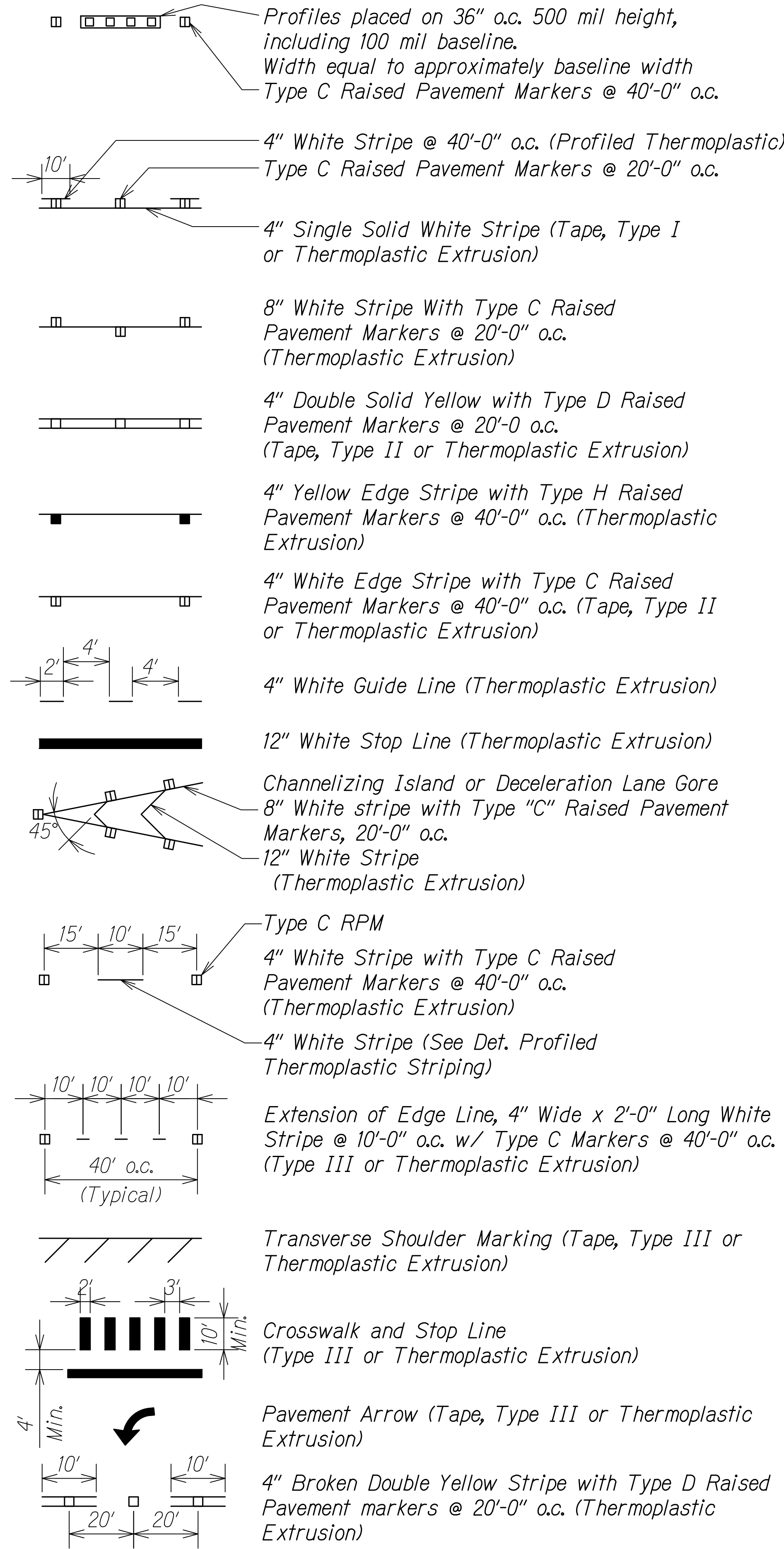
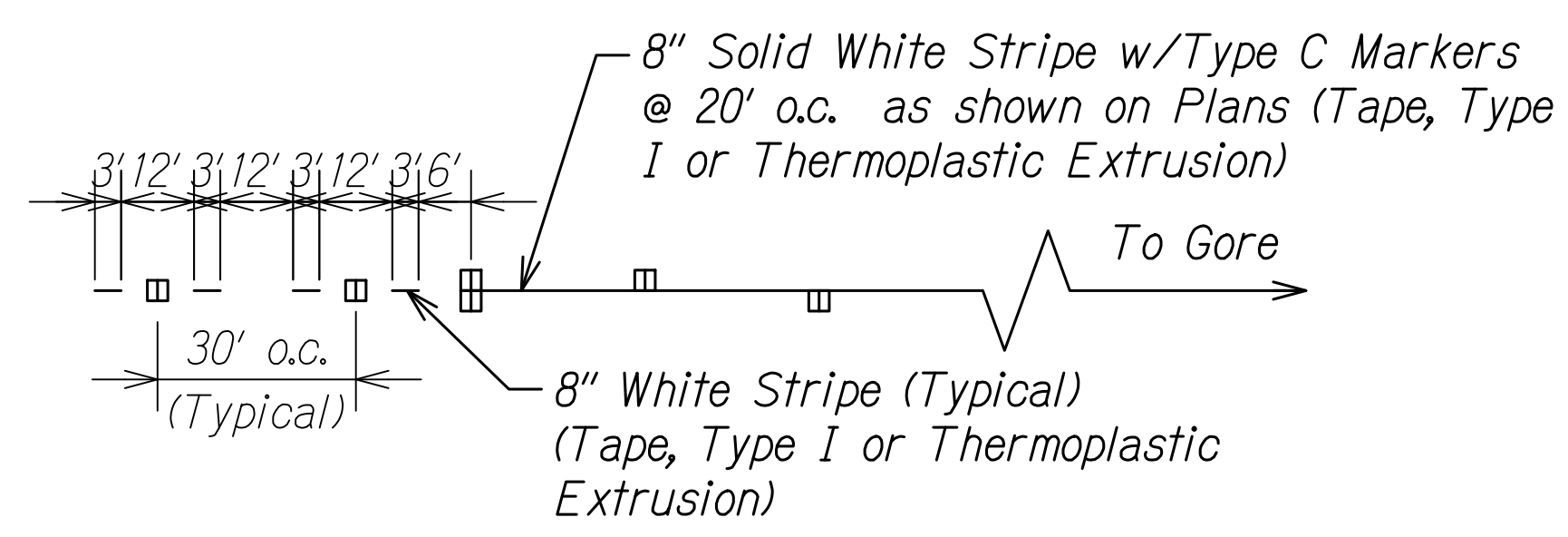

LANE DROP MARKING
Not to Scale

SIGNING AND PAVEMENT MARKING NOTES:

- Layout of pavement markings and striping shall be done by the Contractor and approved by the Engineer prior to any installation work.
- Existing pavement markings and striping not incorporated in the final traffic pattern shall be removed as directed by the Engineer. The removal of the existing pavement markings shall not be paid for separately and shall be considered incidental to the various pavement marking items.
- Raised pavement markers shall not be installed within the crosswalks.
- Final locations of all signs shall be approved by the Engineer prior to any installation work.
- Existing signs not shown on these plans shall remain as posted unless otherwise directed by the Engineer. Removal and disposal of existing signs and/or posts as designated on these plans or directed by the Engineer shall not be paid for and shall be considered incidental to the various signing items.
- Final locations of all stop lines shall be approved by the Engineer prior to installation.
- All pavement striping shall be as noted on the legend or plans.
- Removal of existing delineators and posts as directed by the Engineer shall be considered incidental to the various signing items.
- Existing signs that are to be replaced shall not be removed until new signs are installed as replacements, or the messages are no longer necessary.
- Backing for all new regulatory and warning signs shall not be spliced.
- All sign panels shall conform to the latest and adopted editions and amendments of the following FHWA publications:
 - "Manual on Uniform Traffic Control Devices for Street and Highways" (MUTCD)
 - "Standard Highway Signs"
 - "Standard Alphabet for Highway Signs"
- Sign messages shall be as indicated on the plans.

- All new and relocated signs and markers installed on pipe post or light standard are to be mounted with band brackets and steel braces.
- All new pedestrian crossing signs shall be Fluorescent Yellow-Green Signs.
- All new and relocated permanent signs (informational, regulatory and warning) installed within HDOT Right-of-Ways shall be coordinated with HWY-OM and shall have a barcode sticker, supplied and installed by the Contractor, placed on the back of each sign identifying the installation date of each sign.
- All new guide signs on H-1 Freeway shall utilize Clearview Font (white legend on dark background) to comply with HWY-T directive per HDOT memo dated February 1, 2019.

SIGNING LEGEND:

- Existing Traffic Sign With 1 Post
- New Traffic Sign With 1 Post
- Existing Traffic Sign With 2 Posts
- New Traffic Sign With 2 Posts

SIGNING KEY:

- 1 Exist. Sign(s) & Post(s) to Remain
- 2 Remove Exist. Sign(s) w/Post(s) & Install New Sign(s) w/ Post(s). Install Type II Reflector Marker (RM-2, Yellow) on New Posts except where there is OMI-3.
- 3 Remove Exist. Sign(s) & Install New Sign(s) on Exist. Post(s)
- 4 Remove Exist. Sign(s) & Install New Sign(s) on Existing Wall Mounted Post(s)
- 5 Remove Exist. Sign(s) & Install New Sign(s) on Bridge Column
- 6 Remove Exist. Sign(s) & Install New Sign(s) on Exist. Fence
- 7 Remove Exist. Sign(s) & Install New Sign(s) on Exist. Column Sign Post
- 8 Remove Exist. Sign(s) & Install New Sign Mounted on Overpass (Bridge) Fascia
- 9 Remove Exist. Sign(s) & Post(s)
- 10 Remove Exist. Overlays & Install New Overlays with Messages over Existing Sign Panels
- 11 Remove Exist. Sign(s) & Install New Sign(s) on Exist. Street Light Post(s)
- 12 Remove Exist. Sign(s) & Install New Sign(s) on Existing Concrete Barrier Mounted Posts
- 13 Reinstall Exist. Sign(s) to New Post

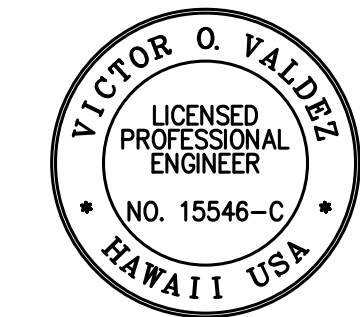

THIS WORK WAS PREPARED BY ME OR UNDER MY SUPERVISION
 Signature: [Signature] 04/30/22
 EXPIRATION DATE OF THE LICENSE

STATE OF HAWAII
 DEPARTMENT OF TRANSPORTATION
 HIGHWAYS DIVISION
**PAVEMENT MARKING
 LEGEND AND NOTES**
 INTERSTATE ROUTE H-1 RESURFACING
 Miller Pedestrian Overpass to Kapiolani Interchange
 Federal-Aid Project No. NH-H1-1(279)
 Scale: N/A Date: August 2021

C:_CIVIL_3D_PROJECTS\2016_2022\000_DOT-HWYS_H1_RESURFACING - MILLER TO KAPITOLI CIVIL DRAWINGS\M1_PAVEMENT MARKING LEGEND AND NOTES.DWG 1/12/2021 7:06 PM

FED. ROAD DIST. NO.	STATE	FED-AID PROJ. NO.	FISCAL YEAR	SHEET NO.	TOTAL SHEETS
HAWAII	HAW.	NH-HI-1(279)	2021	ADD. 143	304

BEGIN PROJECT
FAP No. NH-HI-1(279)
H-1 @ Sta. 172+64

TRUE NORTH
SCALE: 1" = 40'

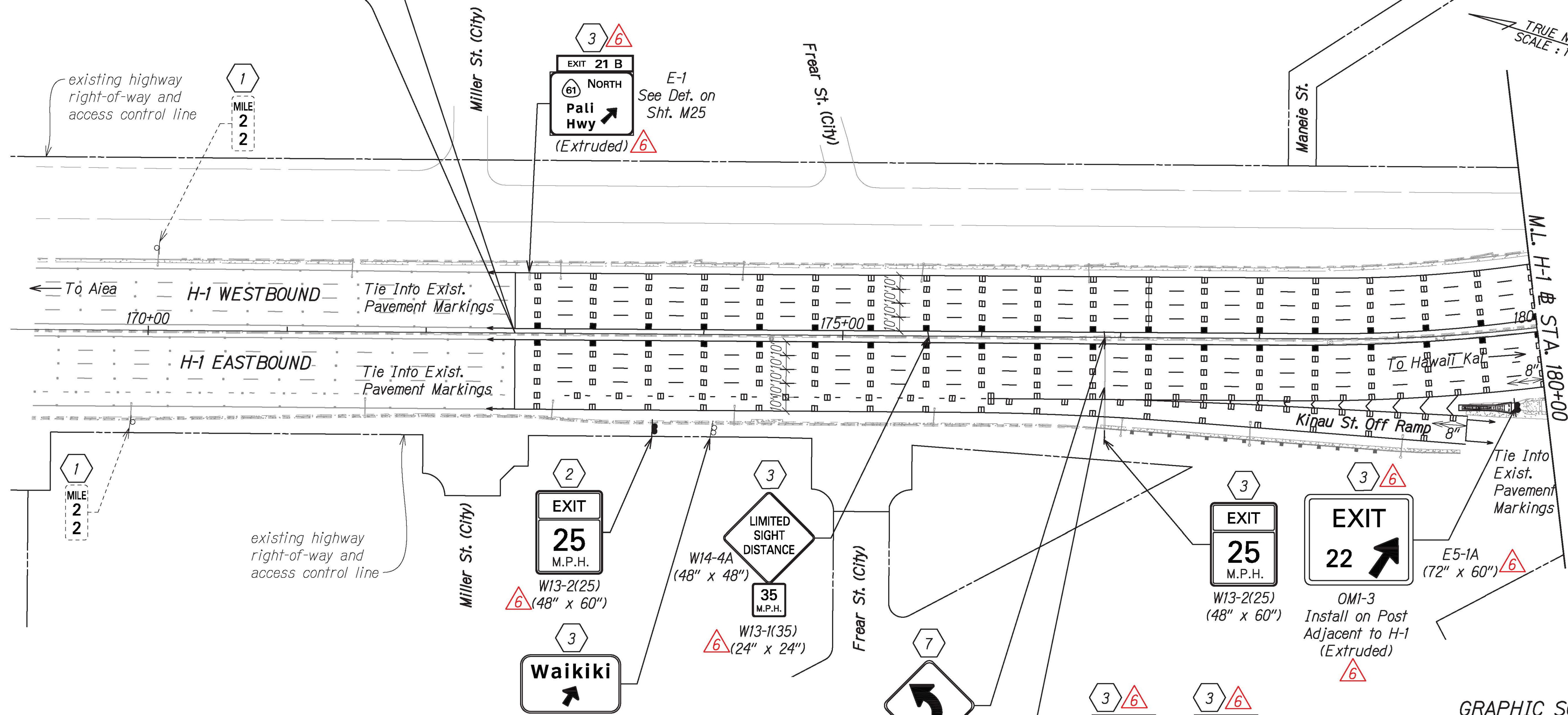

NOTE:
For pavement marking and signing legend, see Sht. M1

SIGNING KEY:

- 1 Exist. Sign(s) & Post(s) to Remain
- 2 Remove Exist. Sign(s) w/ Post(s) & Install New Sign(s) w/ Post(s).
Install Type II Reflector Marker (RM-2, Yellow) on New Posts except where there is OMI-3.
- 3 Remove Exist. Sign(s) & Install New Sign(s) on Exist. Post(s)
- 7 Remove Exist. Sign(s) & Install New Sign(s) on Exist. Column Sign Post

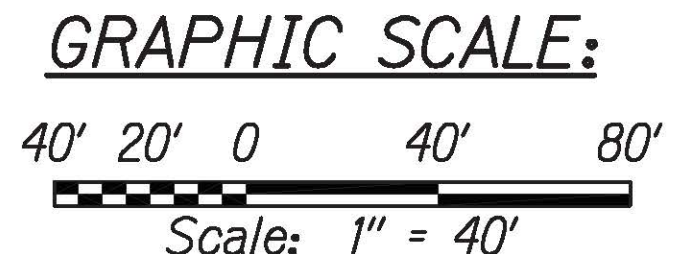

7/21/21	Removed Signing Key No. 10, Updated Sign Size and Updated Reference Note
DATE	REVISION

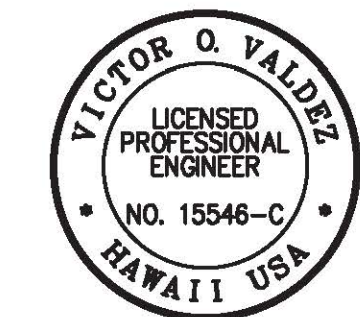

THIS WORK WAS PREPARED BY ME
OR UNDER MY SUPERVISION

[Signature]
SIGNATURE

04/30/22
EXPIRATION DATE
OF THE LICENSE

STATE OF HAWAII
DEPARTMENT OF TRANSPORTATION
HIGHWAYS DIVISION

PAVEMENT MARKING & SIGNING PLAN

INTERSTATE ROUTE H-1 RESURFACING
Miller Pedestrian Overpass to Kapiolani Interchange
Federal-Aid Project No. NH-HI-1(279)

Scale: 1" = 40' Date: August 2021

C:_3D PROJECTS\2016_2022\000_DOT-HWYS H1-RESURFACING - MILLER TO KAPITOLI CIVIL DRAWINGS\M2 - M18 - PAVEMENT MARKING AND SIGNING PLANS.DWG 7/22/2021 8:07 AM

FED. ROAD DIST. NO.	STATE	FED. AID PROJ. NO.	FISCAL YEAR	SHEET NO.	TOTAL SHEETS
HAWAII	HAW.	NH-H1-1(279)	2021	ADD. 144	304

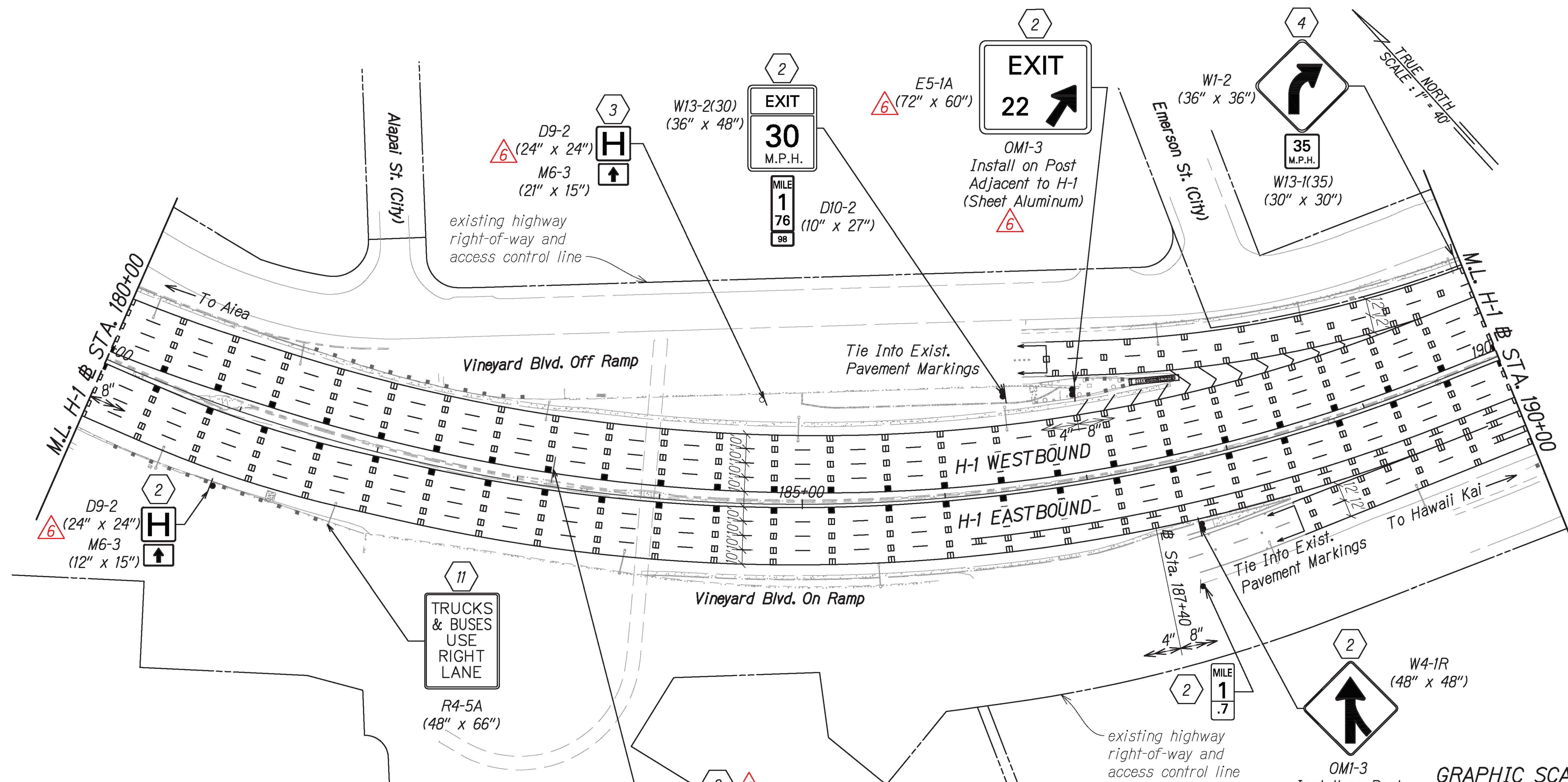

NOTE:
For pavement marking and signing legend, see Sht. M1

SIGNING KEY:

- Remove Exist. Sign(s) w/Post(s) & Install New Sign(s) w/ Post(s).
Install Type II Reflector Marker (RM-2, Yellow) on New Posts except where there is OMI-3.
- Remove Exist. Sign(s) & Install New Sign(s) on Exist. Post(s)
- Remove Exist. Sign(s) & Install New Sign(s) on Existing Wall Mounted Post(s)
- Remove Exist. Sign(s) & Install New Sign(s) on Exist. Street Light Post(s)
- Remove Exist. Sign(s) & Install New Sign(s) on Exist. Street Light Post(s)

Pali Hwy. 1/4
School St. 3/4
Palama St. 1 1/2
E-3
See Def. on Sht. M25 (Extruded)

GRAPHIC SCALE:
40' 20' 0 40' 80'
Scale: 1" = 40'

7/21/21	Removed Signing Key No. 10, Updated Sign Size and Updated Reference Note
DATE	REVISION

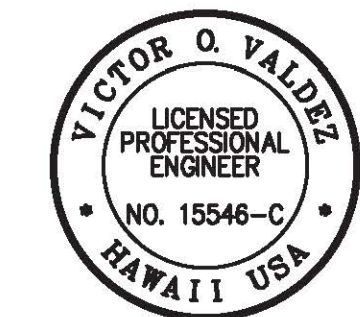

THIS WORK WAS PREPARED BY ME OR UNDER MY SUPERVISION
Victor O. Valdez
SIGNATURE 04/30/22
EXPIRATION DATE OF THE LICENSE

STATE OF HAWAII
DEPARTMENT OF TRANSPORTATION
HIGHWAYS DIVISION
PAVEMENT MARKING & SIGNING PLAN
INTERSTATE ROUTE H-1 RESURFACING
Miller Pedestrian Overpass to Kapiolani Interchange
Federal-Aid Project No. NH-H1-1(279)
Scale: 1" = 40' Date: August 2021

C:_CIVIL_3D_PROJECTS\2016_2022\000_DOT-HWYS H1 RESURFACING - MILLER TO KAPITOLI CIVIL DRAWINGS\M2 - M18_PAVEMENT MARKING AND SIGNING PLANS.DWG 7/22/2021 9:08 AM

FED. ROAD DIST. NO.	STATE	FED. AID PROJ. NO.	FISCAL YEAR	SHEET NO.	TOTAL SHEETS
HAWAII	HAW.	NH-HI-1(279)	2021	ADD. 145	304

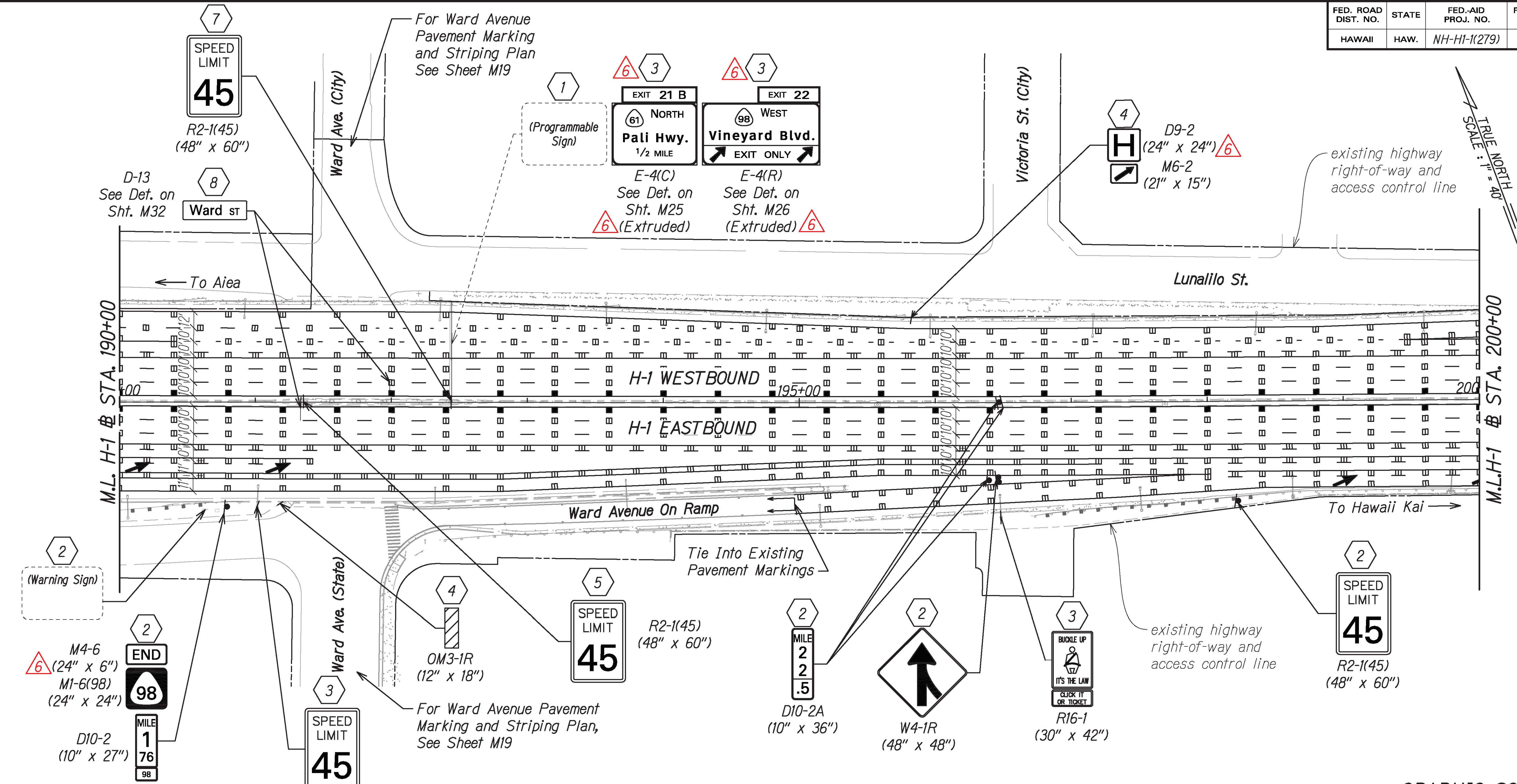

SIGNING KEY:

- 1 Exist. Sign(s) & Post(s) to Remain
- 2 Remove Exist. Sign(s) w/Post(s) & Install New Sign(s) w/ Post(s).
Install Type II Reflector Marker (RM-2, Yellow) on New Posts except where there is OM1-3.
- 3 Remove Exist. Sign(s) & Install New Sign(s) on Exist. Post(s)
- 4 Remove Exist. Sign(s) & Install New Sign(s) Mounted on Wall
- 5 Remove Exist. Sign(s) & Install New Sign(s) on Bridge Column
- 7 Remove Exist. Sign(s) & Install New Sign(s) on Exist. Column Sign Post
- 8 Remove Exist. Sign(s) & Install New Sign Mounted on Overpass (Bridge) Fascia

NOTE:
For pavement marking and signing legend, see Sht. M1

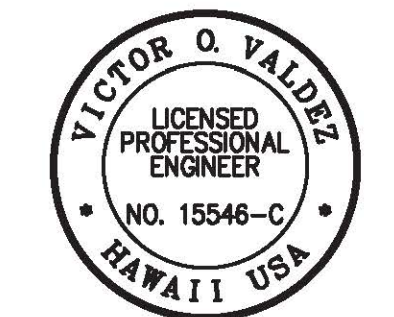
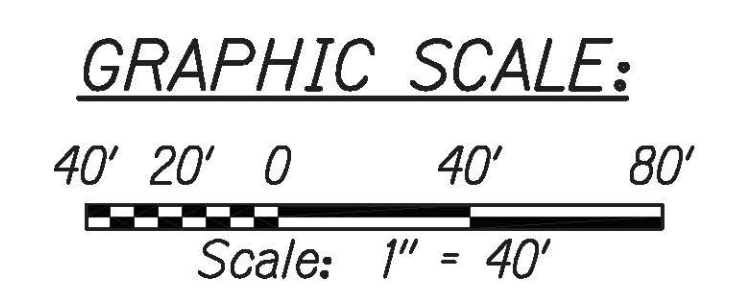

THIS WORK WAS PREPARED BY ME
OR UNDER MY SUPERVISION

[Signature] 04/30/22
SIGNATURE EXPIRATION DATE OF THE LICENSE

7/21/21	Removed Signing Key No. 10, Updated Sign Size and Updated Reference Note
DATE	REVISION
STATE OF HAWAII DEPARTMENT OF TRANSPORTATION HIGHWAYS DIVISION PAVEMENT MARKING & SIGNING PLAN INTERSTATE ROUTE H-1 RESURFACING Miller Pedestrian Overpass to Kapiolani Interchange Federal-Aid Project No. NH-HI-1(279)	
Scale: 1" = 40'	Date: August 2021
SHEET No. M4 OF 34 SHEETS	

C:_CIVIL_3D_PROJECTS\2016_2022\000_DOT-HWYS H1-RESURFACING - MILLER TO KAPITOLI CIVIL DRAWINGS\M2 - M18_PAVEMENT MARKING AND SIGNING PLANS.DWG 7/22/2021 9:11 AM

FED. ROAD DIST. NO.	STATE	FED. AID PROJ. NO.	FISCAL YEAR	SHEET NO.	TOTAL SHEETS
HAWAII	HAW.	NH-H1-1(279)	2021	ADD. 146	304

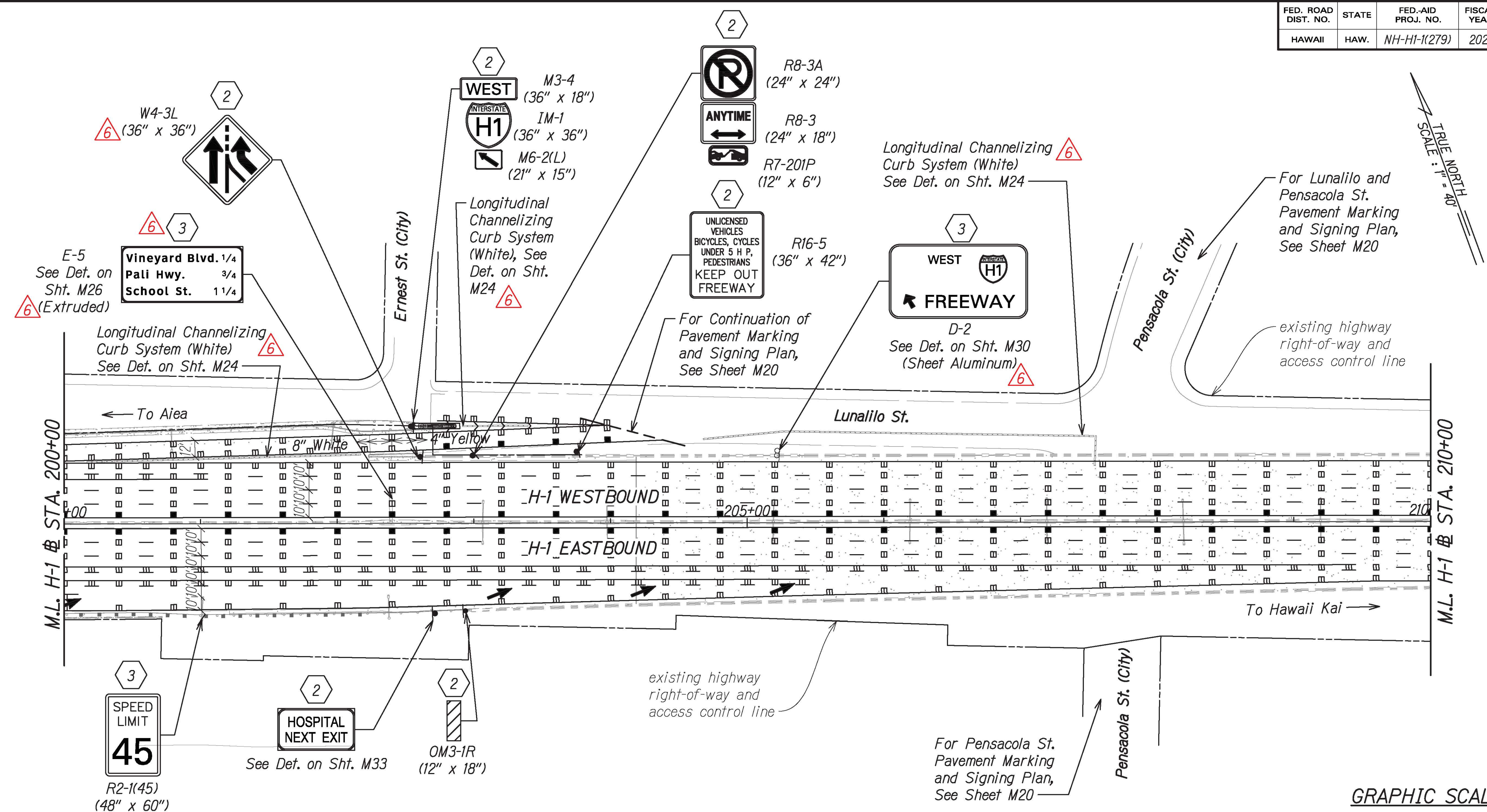

NOTE:
For pavement marking and signing legend, see Sht. M1

SIGNING KEY:

- 2 Remove Exist. Sign(s) w/Post(s) & Install New Sign(s) w/ Post(s).
Install Type II Reflector Marker (RM-2, Yellow) on New Posts except where there is OMI-3.
- 3 Remove Exist. Sign(s) & Install New Sign(s) on Exist. Post(s)
- 6

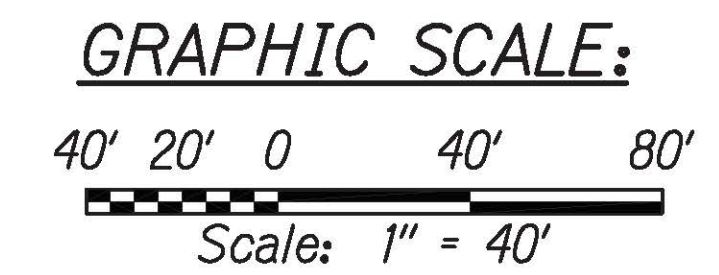

7/21/21	Removed Signing Key No. 10, Updated Sign Size and Updated Reference Note and Callout
DATE	REVISION

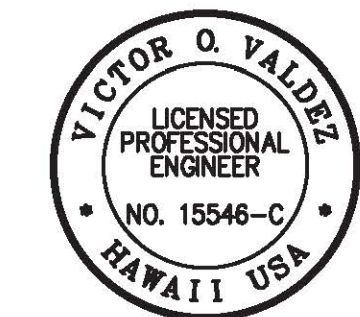

THIS WORK WAS PREPARED BY ME OR UNDER MY SUPERVISION

Victor O. Valdez
SIGNATURE

04/30/22
EXPIRATION DATE OF THE LICENSE

STATE OF HAWAII
DEPARTMENT OF TRANSPORTATION
HIGHWAYS DIVISION

PAVEMENT MARKING & SIGNING PLAN

INTERSTATE ROUTE H-1 RESURFACING
Miller Pedestrian Overpass to Kapiolani Interchange
Federal-Aid Project No. NH-H1-1(279)

Scale: 1" = 40' Date: August 2021

C:_CIVIL_3D_PROJECTS\2016_2022\000_DOT-HWYS H1_RESURFACING - MILLER TO KAPITOLI CIVIL DRAWINGS\M2 - M18_PAVEMENT MARKING AND SIGNING PLANS.DWG 7/28/2021 10:33 PM

FED. ROAD DIST. NO.	STATE	FED. AID PROJ. NO.	FISCAL YEAR	SHEET NO.	TOTAL SHEETS
HAWAII	HAW.	NH-HI-1(279)	2021	ADD. 147	304

TRUE NORTH
SCALE: 1" = 40'

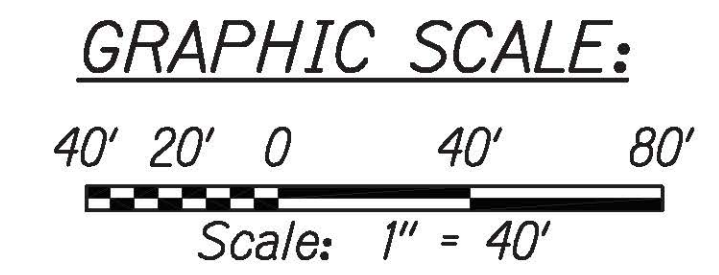
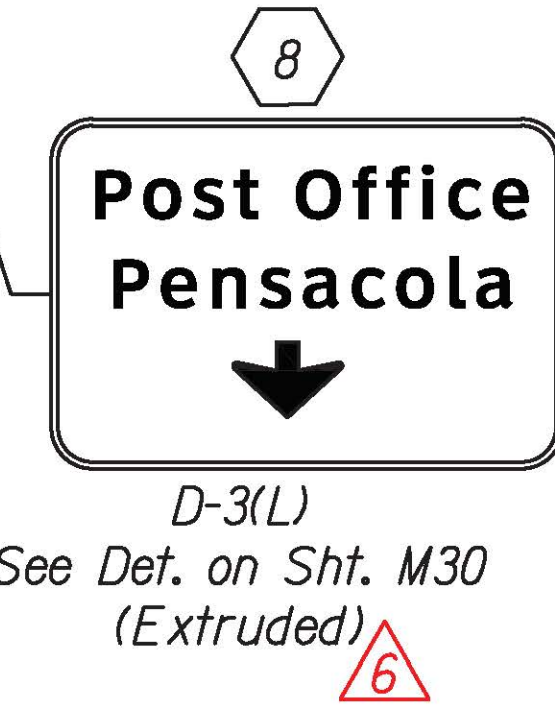
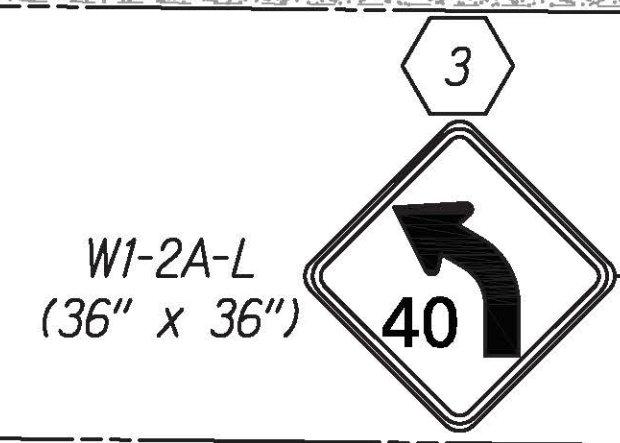
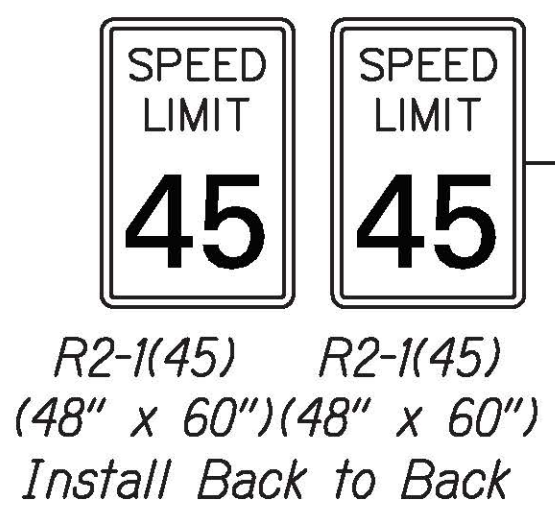
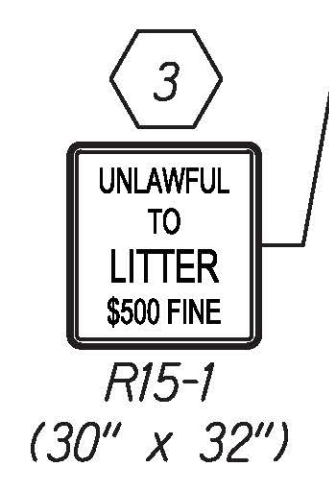
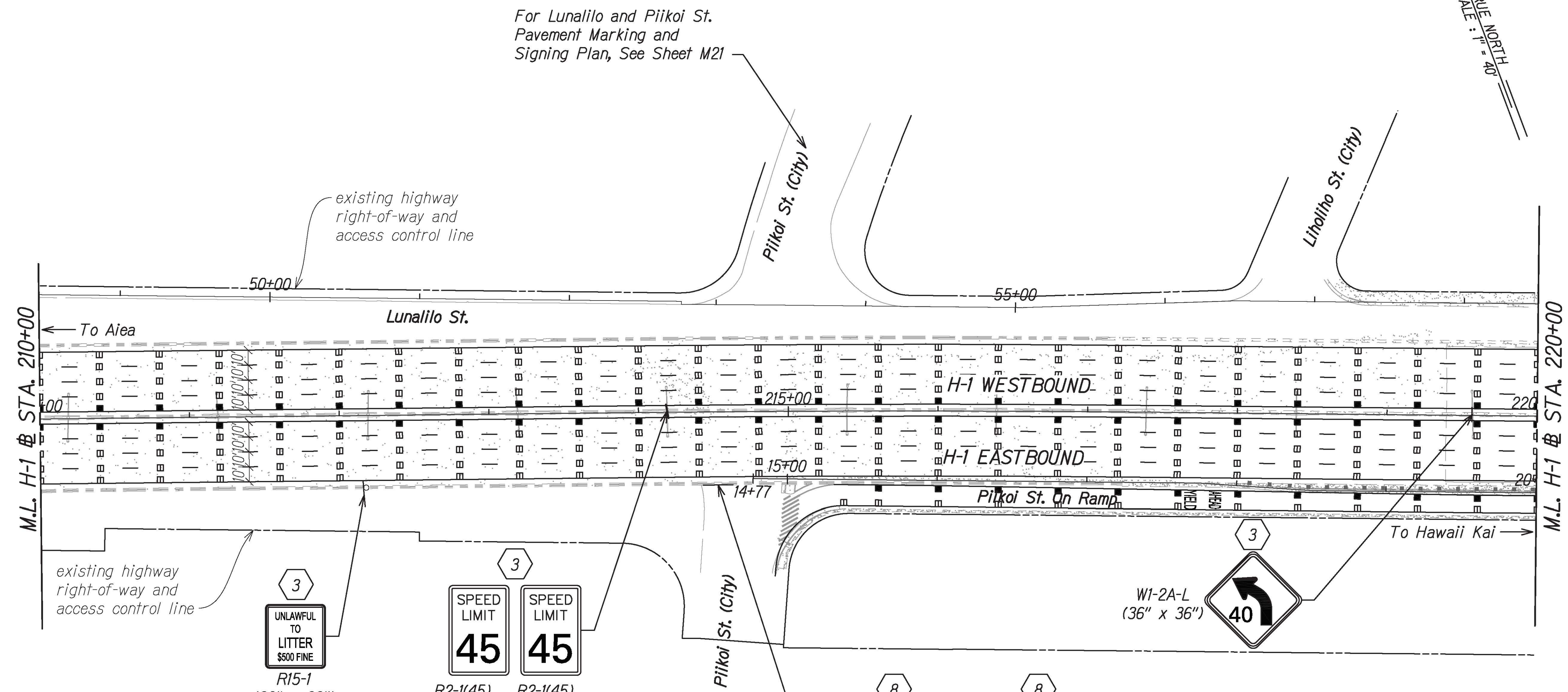

NOTE:
For pavement marking and signing legend, see Sht. M1

- SIGNING KEY:**
- 3 Remove Exist. Sign(s) & Install New Sign(s) on Exist. Post(s)
 - 8 Remove Exist. Sign(s) & Install New Sign Mounted on Overpass (Bridge) Fascia

DATE	REVISION
7/21/21	6 Updated Callout

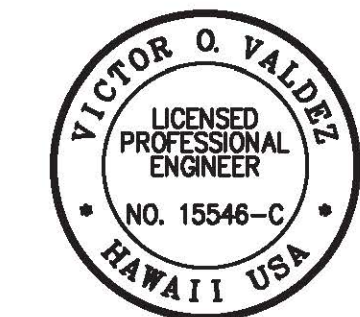

THIS WORK WAS PREPARED BY ME OR UNDER MY SUPERVISION
 SIGNATURE: [Signature] 04/30/22
 EXPIRATION DATE OF THE LICENSE

STATE OF HAWAII
 DEPARTMENT OF TRANSPORTATION
 HIGHWAYS DIVISION
PAVEMENT MARKING & SIGNING PLAN
 INTERSTATE ROUTE H-1 RESURFACING
 Miller Pedestrian Overpass to Kapiolani Interchange
 Federal-Aid Project No. NH-HI-1(279)
 Scale: 1" = 40' Date: August 2021

C:_CIVIL_3D_PROJECTS\2016_2022\000_DOT-HWYS H1 RESURFACING - MILLER TO KAPITANI\01 CIVIL DRAWINGS\M2 - M18 PAVEMENT MARKING AND SIGNING PLANS.DWG 7/22/2021 7:35 AM

FED. ROAD DIST. NO.	STATE	FED-AID PROJ. NO.	FISCAL YEAR	SHEET NO.	TOTAL SHEETS
HAWAII	HAW.	NH-HI-1(279)	2021	ADD. 148	304

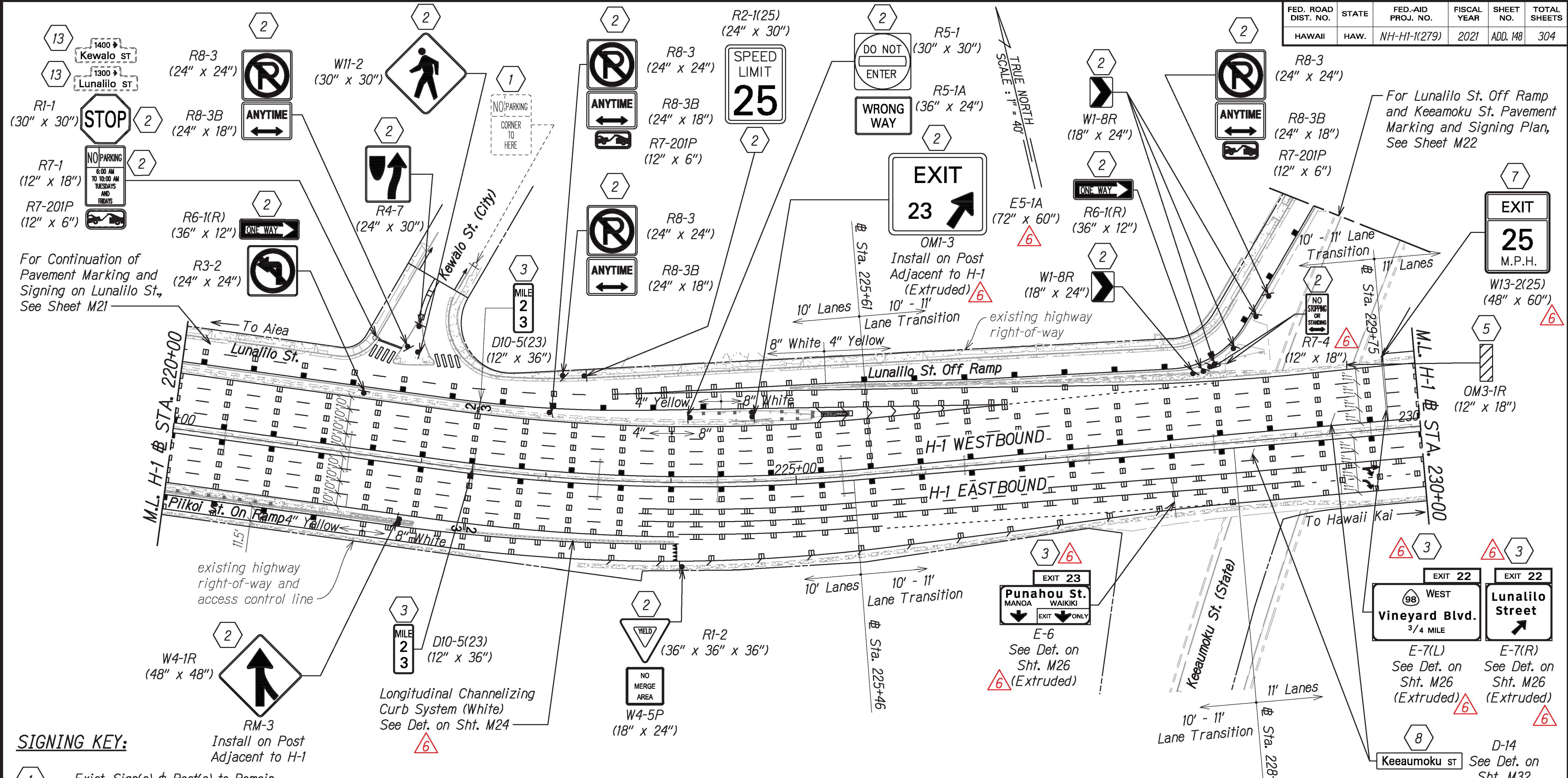

SIGNING KEY:

- 1 Exist. Sign(s) & Post(s) to Remain
- 2 Remove Exist. Sign(s) w/Post(s) & Install New Sign(s) w/ Post(s).
Install Type II Reflector Marker (RM-2, Yellow) on New Posts except where there is OMI-3.
- 3 Remove Exist. Sign(s) & Install New Sign(s) on Exist. Post(s)
- 5 Remove Exist. Sign(s) & Install New Sign(s) on Bridge Column
- 7 Remove Exist. Sign(s) & Install New Sign(s) on Exist. Column Sign Post
- 8 Remove Exist. Sign(s) & Install New Sign Mounted on Overpass (Bridge) Fascia
- 6 Reinstall Exist. Sign(s) to New Post

NOTE:

For pavement marking and signing legend, see Sht. M1

GRAPHIC SCALE:

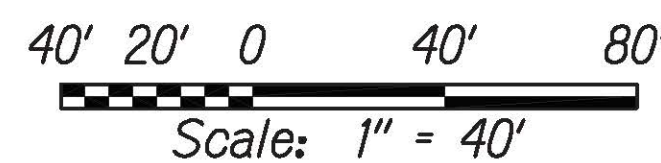

THIS WORK WAS PREPARED BY ME OR UNDER MY SUPERVISION

SIGNATURE: *[Signature]* 04/30/22
EXPIRATION DATE OF THE LICENSE

7/21/21	Removed Signing Key No. 10, Updated Sign Size and Updated Reference Note and Callout
DATE	REVISION

STATE OF HAWAII
DEPARTMENT OF TRANSPORTATION
HIGHWAYS DIVISION

PAVEMENT MARKING & SIGNING PLAN

INTERSTATE ROUTE H-1 RESURFACING
Miller Pedestrian Overpass to Kapiolani Interchange
Federal-Aid Project No. NH-HI-1(279)

Scale: 1" = 40' Date: August 2021

C:_CIVIL_3D_PROJECTS\2016_2022\000_DOT-HWYS H1-RESURFACING - MILLER TO KAPITOLI CIVIL DRAWINGS\M2 - M18_PAVEMENT MARKING AND SIGNING PLANS.DWG 7/28/2021 11:14 PM

FED. ROAD DIST. NO.	STATE	FED-AID PROJ. NO.	FISCAL YEAR	SHEET NO.	TOTAL SHEETS
HAWAII	HAW.	NH-H1-1(279)	2021	ADD. 149	304

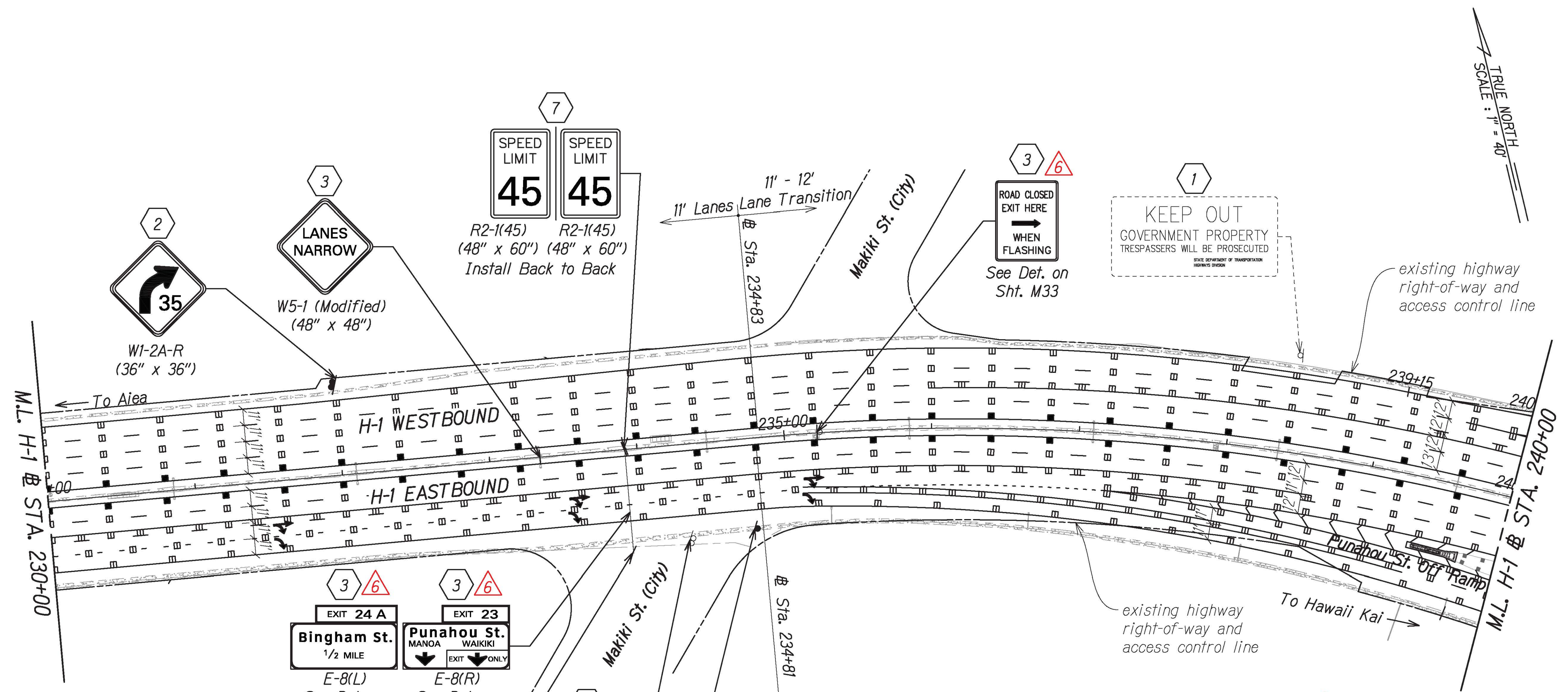

TRUE NORTH
SCALE: 1" = 40'

NOTE:
For pavement marking and signing legend, see Sht. M1

SIGNING KEY:

- 1 Exist. Sign(s) & Post(s) to Remain
- 2 Remove Exist. Sign(s) w/Post(s) & Install New Sign(s) w/ Post(s). Install Type II Reflector Marker (RM-2, Yellow) on New Posts except where there is OMI-3.
- 3 Remove Exist. Sign(s) & Install New Sign(s) on Exist. Post(s)
- 7 Remove Exist. Sign(s) & Install New Sign(s) on Exist. Column Sign Post
- 6 Remove Exist. Sign(s) & Install New Sign(s) on Existing Concrete Barrier Mounted Post(s)
- 12 Remove Exist. Sign(s) & Install New Sign(s) on Existing Concrete Barrier Mounted Post(s)

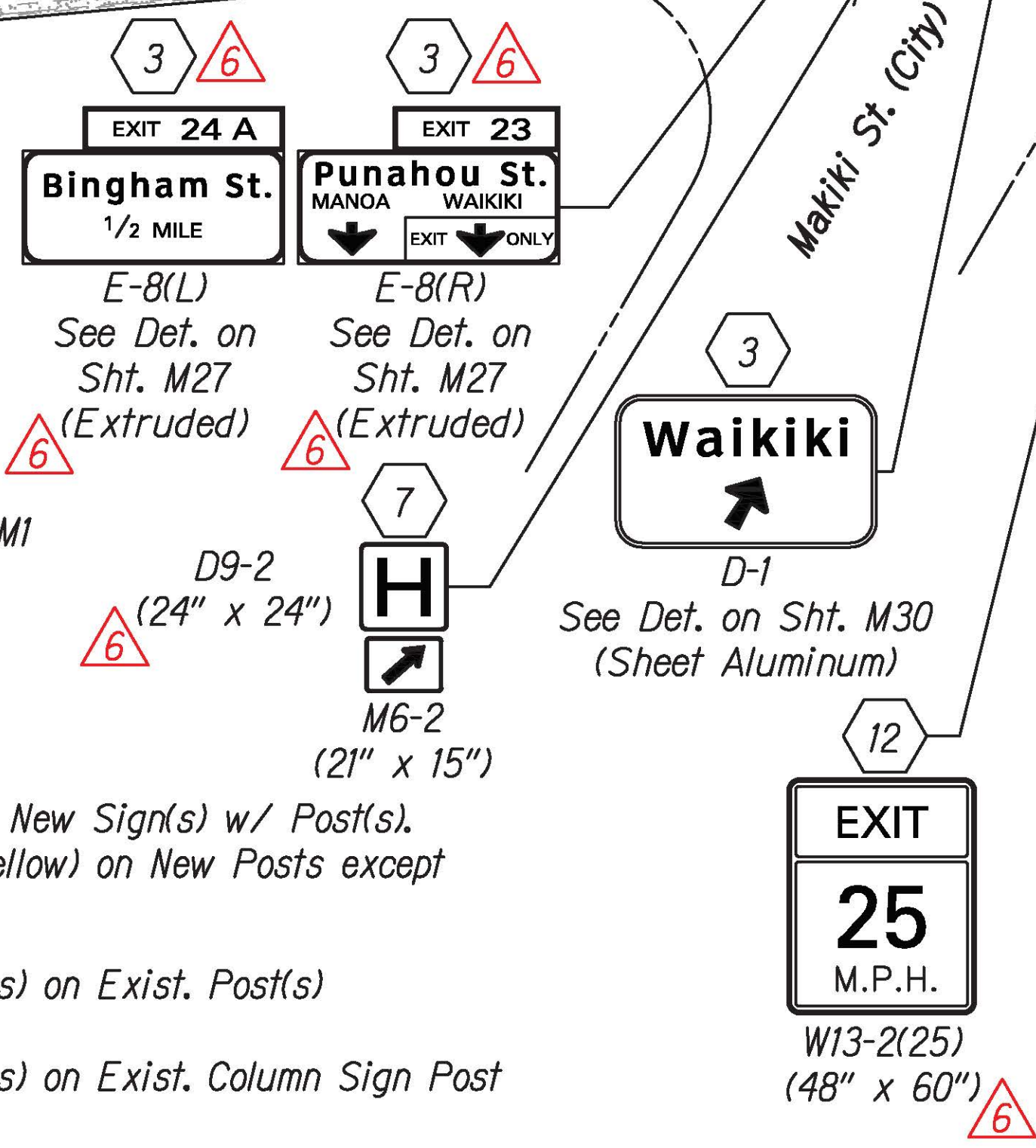

NOTE:
For pavement marking and signing legend, see Sht. M1

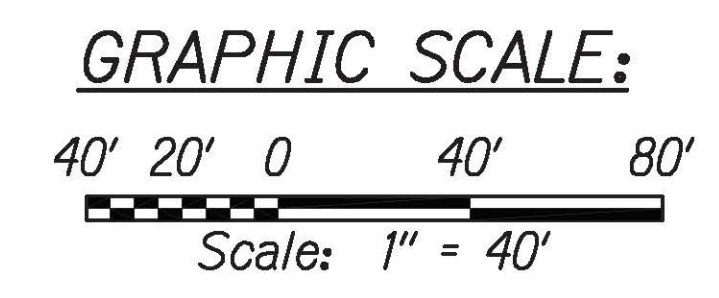

DATE	REVISION
7/21/21	Removed Signing Key No. 10, Updated Sign Size and Updated Reference Note and Callout

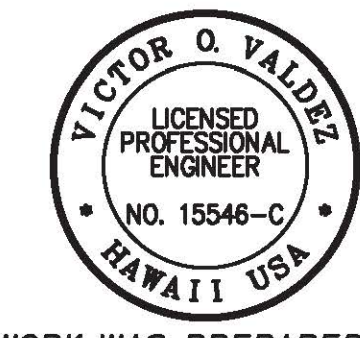

THIS WORK WAS PREPARED BY ME OR UNDER MY SUPERVISION
 SIGNATURE: [Signature] EXPIRATION DATE OF THE LICENSE: 04/30/22

STATE OF HAWAII
 DEPARTMENT OF TRANSPORTATION
 HIGHWAYS DIVISION
PAVEMENT MARKING & SIGNING PLAN
 INTERSTATE ROUTE H-1 RESURFACING
 Miller Pedestrian Overpass to Kapiolani Interchange
 Federal-Aid Project No. NH-H1-1(279)
 Scale: 1" = 40' Date: August 2021
 SHEET No. M8 OF 34 SHEETS

C:_CIVIL_3D_PROJECTS\2016_2021\000_DOT-HWYS H1_RESURFACING - MILLER TO KAPITOLI CIVIL DRAWINGS\M2 - M18_PAVEMENT MARKING AND SIGNING PLANS.DWG 7/28/2021 8:59 PM

FED. ROAD DIST. NO.	STATE	FED. AID PROJ. NO.	FISCAL YEAR	SHEET NO.	TOTAL SHEETS
HAWAII	HAW.	NH-H1-1(279)	2021	ADD. 150	304

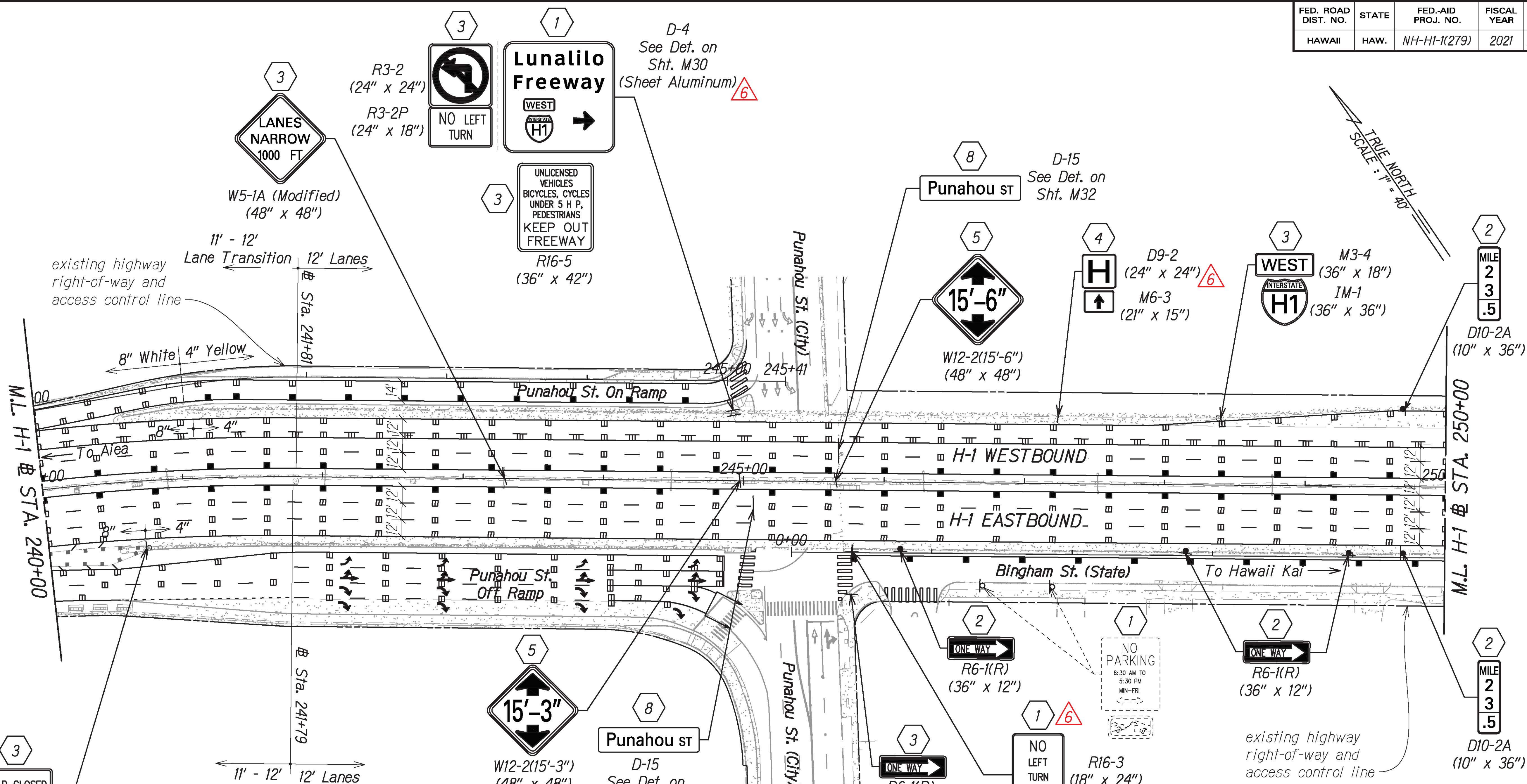

TRUE NORTH
SCALE: 1" = 40'

GRAPHIC SCALE:
40' 20' 0 40' 80'
Scale: 1" = 40'

NOTE:
For pavement marking and signing legend, see Sht. M1

- SIGNING KEY:**
- 1 Exist. Sign(s) & Post(s) to Remain
 - 2 Remove Exist. Sign(s) w/ Post(s) & Install New Sign(s) w/ Post(s). Install Type II Reflector Marker (RM-2, Yellow) on New Posts except where there is OMI-3.
 - 3 Remove Exist. Sign(s) & Install New Sign(s) on Exist. Post(s)
 - 4 Remove Exist. Sign(s) & Install New Sign(s) Mounted on Wall
 - 5 Remove Exist. Sign(s) & Install New Sign(s) on Bridge Column
 - 8 Remove Exist. Sign(s) & Install New Sign Mounted on Overpass (Bridge) Fascia

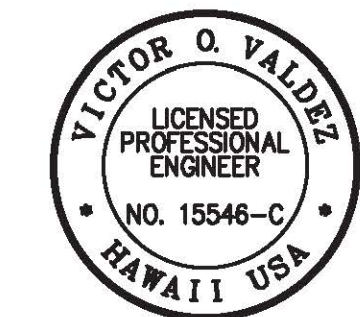

THIS WORK WAS PREPARED BY ME OR UNDER MY SUPERVISION
 SIGNATURE: [Signature] 04/30/22
 EXPIRATION DATE OF THE LICENSE

7/21/21	Updated Sign Size and Updated Reference Note and Callout
DATE	REVISION
STATE OF HAWAII DEPARTMENT OF TRANSPORTATION HIGHWAYS DIVISION PAVEMENT MARKING & SIGNING PLAN INTERSTATE ROUTE H-1 RESURFACING Miller Pedestrian Overpass to Kapiolani Interchange Federal-Aid Project No. NH-H1-1(279) Scale: 1" = 40' Date: August 2021 SHEET No. M9 OF 34 SHEETS	

C:_CIVIL_3D_PROJECTS\2016_2022\000_DOT-HWYS H1-RESURFACING - MILLER TO KAPUNIYOI CIVIL DRAWINGS\M2 - M18_PAVEMENT MARKING AND SIGNING PLANS.DWG 7/28/2021 8:58 PM

FED. ROAD DIST. NO.	STATE	FED. AID PROJ. NO.	FISCAL YEAR	SHEET NO.	TOTAL SHEETS
HAWAII	HAW.	NH-H1-1(279)	2021	ADD. 151	304

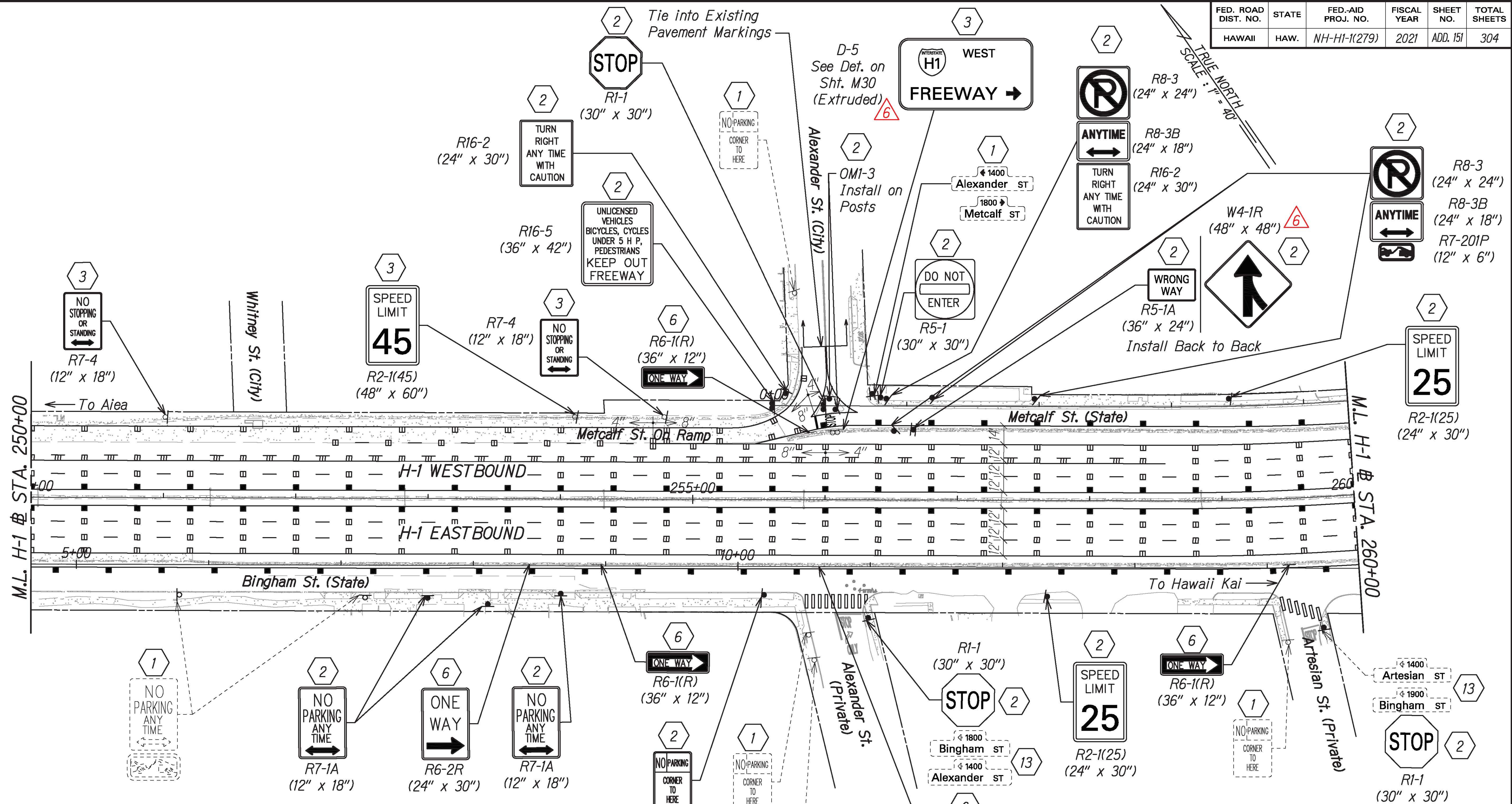

NOTE:
For pavement marking and signing legend, see Sht. M1

SIGNING KEY:

- 1 Exist. Sign(s) & Post(s) to Remain
- 2 Remove Exist. Sign(s) w/Post(s) & Install New Sign(s) w/ Post(s).
Install Type II Reflector Marker (RM-2, Yellow) on New Posts except where there is OMI-3.
- 3 Remove Exist. Sign(s) & Install New Sign(s) on Exist. Post(s)
- 6 Remove Exist. Sign(s) & Install New Sign(s) on Exist. Fence
- 13 Reinstall Exist. Sign(s) to New Post

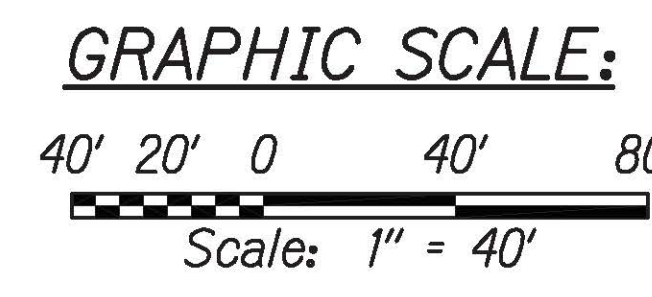

VICTOR O. VALDEZ
LICENSED PROFESSIONAL ENGINEER
NO. 15546-C
HAWAII USA

THIS WORK WAS PREPARED BY ME OR UNDER MY SUPERVISION

[Signature]
SIGNATURE

04/30/22
EXPIRATION DATE OF THE LICENSE

7/21/21	Updated Sign Size and Updated Reference Note and Callout
DATE	REVISION
STATE OF HAWAII DEPARTMENT OF TRANSPORTATION HIGHWAYS DIVISION	
PAVEMENT MARKING & SIGNING PLAN	
INTERSTATE ROUTE H-1 RESURFACING Miller Pedestrian Overpass to Kapiolani Interchange Federal-Aid Project No. NH-H1-1(279)	
Scale: 1" = 40'	Date: August 2021
SHEET No. M10 OF 34 SHEETS	

C:_CIVIL_3D_PROJECTS\2016_2022\000_DOT-HWYS H1-RESURFACING - MILLER TO KAPITANI\01_CIVIL DRAWINGS\M2 - M18_PAVEMENT MARKING AND SIGNING PLANS.DWG 7/22/2021 7:35 AM

FED. ROAD DIST. NO.	STATE	FED-AID PROJ. NO.	FISCAL YEAR	SHEET NO.	TOTAL SHEETS
HAWAII	HAW.	NH-HI-1(279)	2021	ADD. 152	304

C:_CIVIL_3D_PROJECTS\2016_2022\000_DOT-HWAYS HI-RESURFACING - MILLER TO KAPUNIYOI CIVIL DRAWINGS\M2 - M18_PAVEMENT MARKING AND SIGNING PLANS.DWG 7/22/2021 7:35 AM

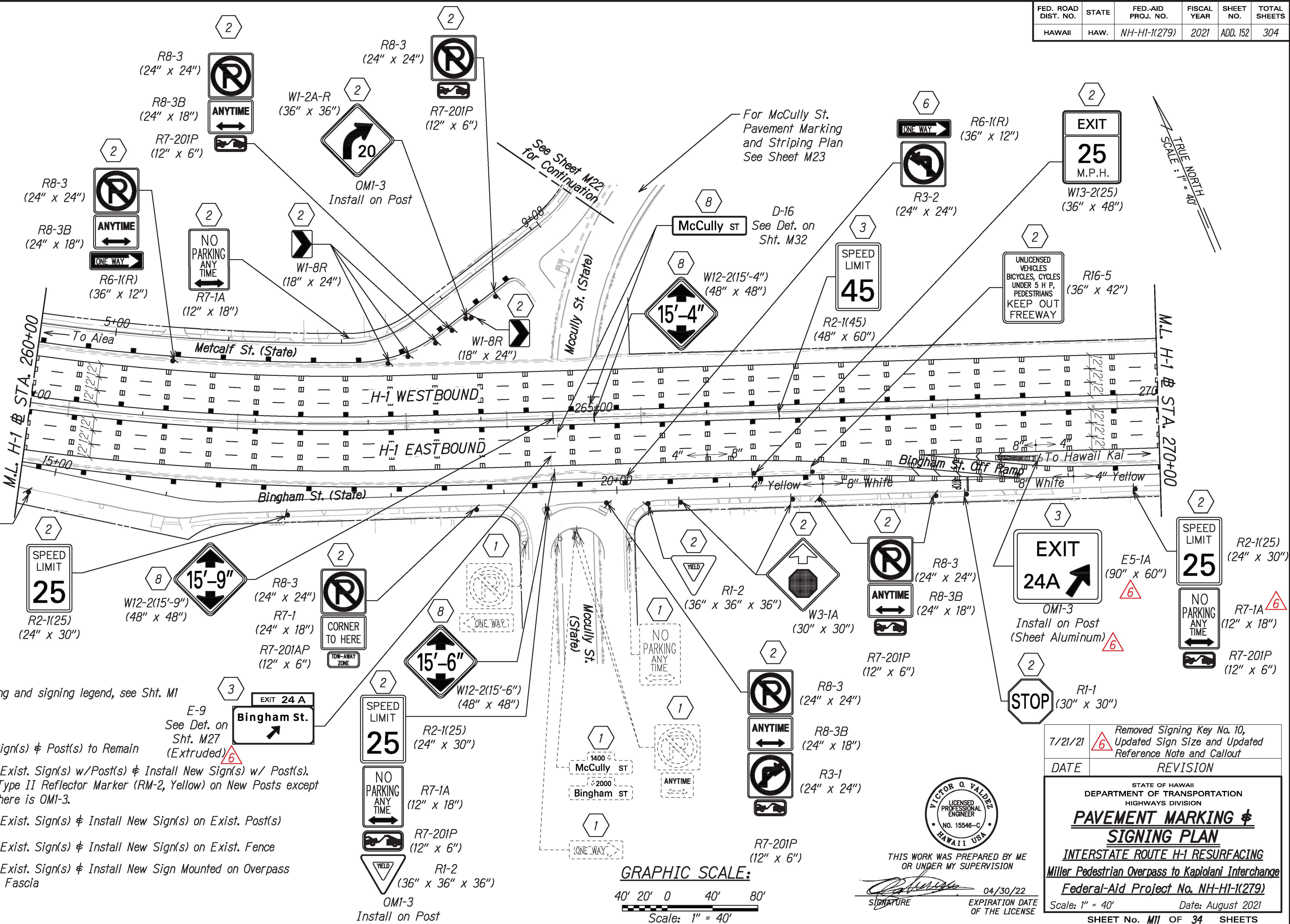

NOTE:

For pavement marking and signing legend, see Sht. M1

SIGNING KEY:

- 1 Exist. Sign(s) & Post(s) to Remain
- 2 Remove Exist. Sign(s) w/ Post(s) & Install New Sign(s) w/ Post(s). Install Type II Reflector Marker (RM-2, Yellow) on New Posts except where there is OM1-3.
- 3 Remove Exist. Sign(s) & Install New Sign(s) on Exist. Post(s)
- 6 Remove Exist. Sign(s) & Install New Sign(s) on Exist. Fence
- 8 Remove Exist. Sign(s) & Install New Sign Mounted on Overpass (Bridge) Fascia

E-9
See Det. on Sht. M27
(Extruded)

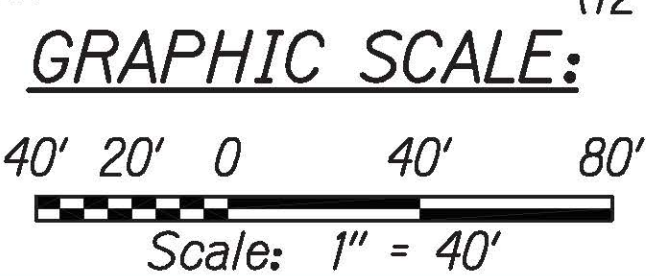

THIS WORK WAS PREPARED BY ME OR UNDER MY SUPERVISION

SIGNATURE: *[Signature]* 04/30/22
EXPIRATION DATE OF THE LICENSE

7/21/21	Removed Signing Key No. 10, Updated Sign Size and Updated Reference Note and Callout
DATE	REVISION
STATE OF HAWAII DEPARTMENT OF TRANSPORTATION HIGHWAYS DIVISION	
PAVEMENT MARKING & SIGNING PLAN	
INTERSTATE ROUTE H-1 RESURFACING Miller Pedestrian Overpass to Kapiolani Interchange Federal-Aid Project No. NH-HI-1(279)	
Scale: 1" = 40'	Date: August 2021
SHEET No. M11 OF 34 SHEETS	

FED. ROAD DIST. NO.	STATE	FED-AID PROJ. NO.	FISCAL YEAR	SHEET NO.	TOTAL SHEETS
HAWAII	HAW.	NH-HI-1(279)	2021	ADD. 153	304

TRUE NORTH
SCALE: 1" = 40'

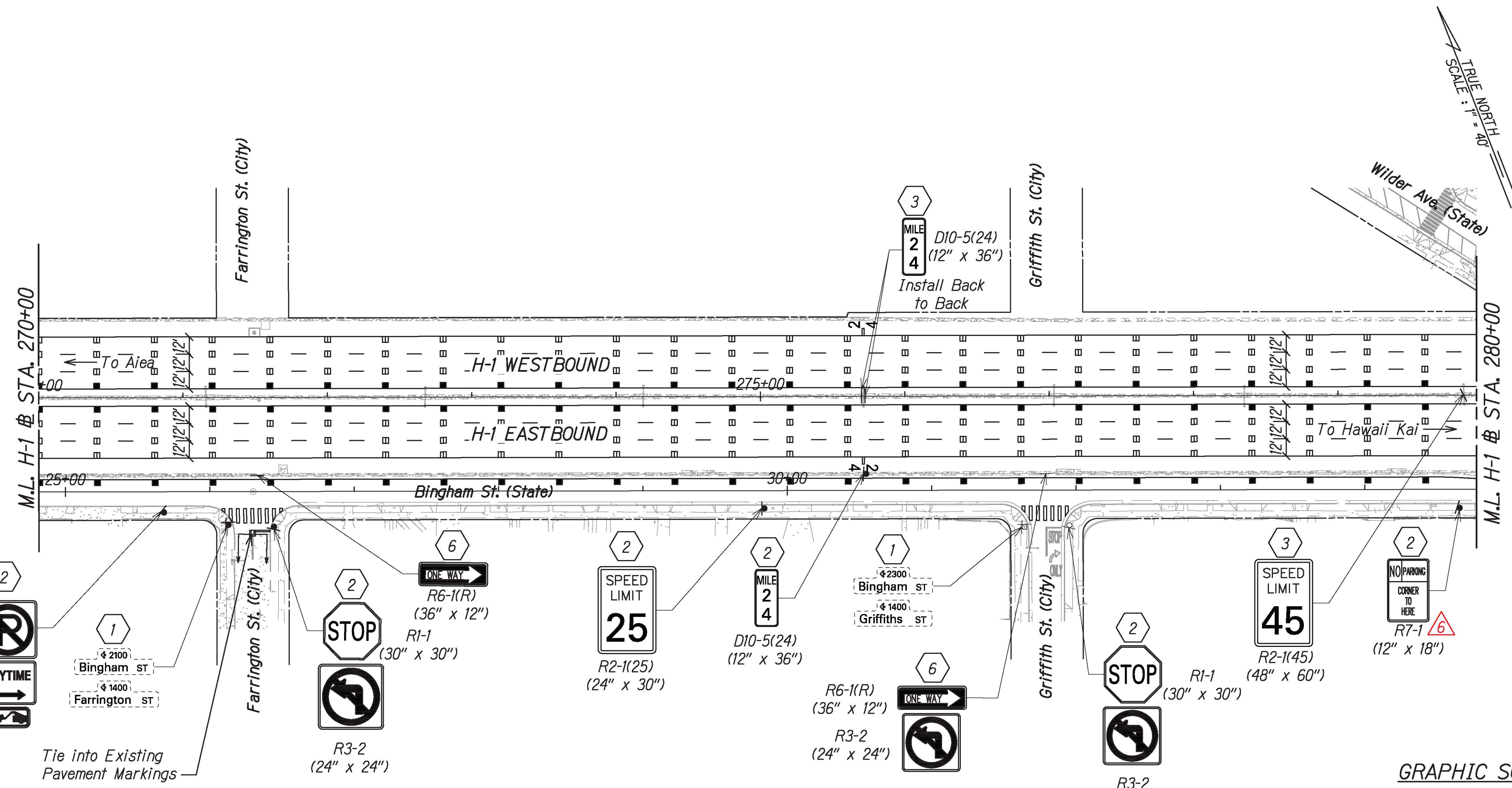

- R8-3 (24" x 24")
- R8-3B (24" x 18")
- R7-201P (12" x 6")

Tie into Existing Pavement Markings

NOTE:
For pavement marking and signing legend, see Sht. M1

SIGNING KEY:

- 1 Exist. Sign(s) & Post(s) to Remain
- 2 Remove Exist. Sign(s) w/ Post(s) & Install New Sign(s) w/ Post(s). Install Type II Reflector Marker (RM-2, Yellow) on New Posts except where there is OMI-3.
- 3 Remove Exist. Sign(s) & Install New Sign(s) on Exist. Post(s)
- 6 Remove Exist. Sign(s) & Install New Sign(s) on Exist. Fence

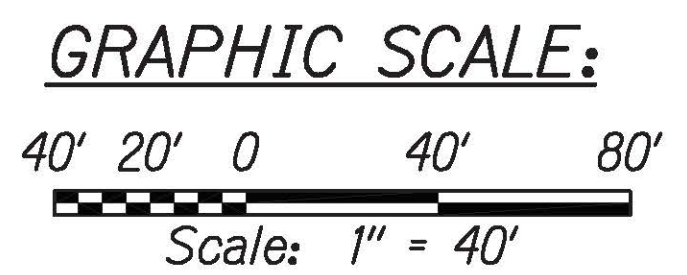

7/21/21	Updated Sign Description
DATE	REVISION
STATE OF HAWAII DEPARTMENT OF TRANSPORTATION HIGHWAYS DIVISION PAVEMENT MARKING & SIGNING PLAN INTERSTATE ROUTE H-1 RESURFACING Miller Pedestrian Overpass to Kapiolani Interchange Federal-Aid Project No. NH-HI-1(279)	
Scale: 1" = 40'	Date: August 2021
SHEET No. M12 OF 34 SHEETS	

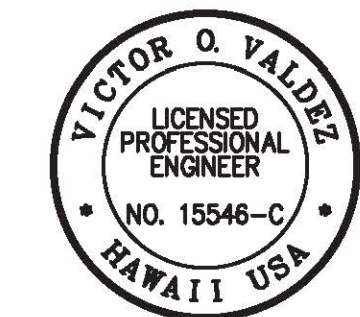

THIS WORK WAS PREPARED BY ME OR UNDER MY SUPERVISION
 SIGNATURE: [Signature] EXPIRATION DATE OF THE LICENSE: 04/30/22

C:_CIVIL_3D_PROJECTS\2016_2022\000_DOT-HWYS H1 RESURFACING - MILLER TO KAPITANI\01_CIVIL DRAWINGS\M2 - M18_PAVEMENT MARKING AND SIGNING PLANS.DWG 7/22/2021 7:50 AM

FED. ROAD DIST. NO.	STATE	FED-AID PROJ. NO.	FISCAL YEAR	SHEET NO.	TOTAL SHEETS
HAWAII	HAW.	NH-HI-1(279)	2021	ADD. 154	304

TRUE NORTH
SCALE: 1" = 40'

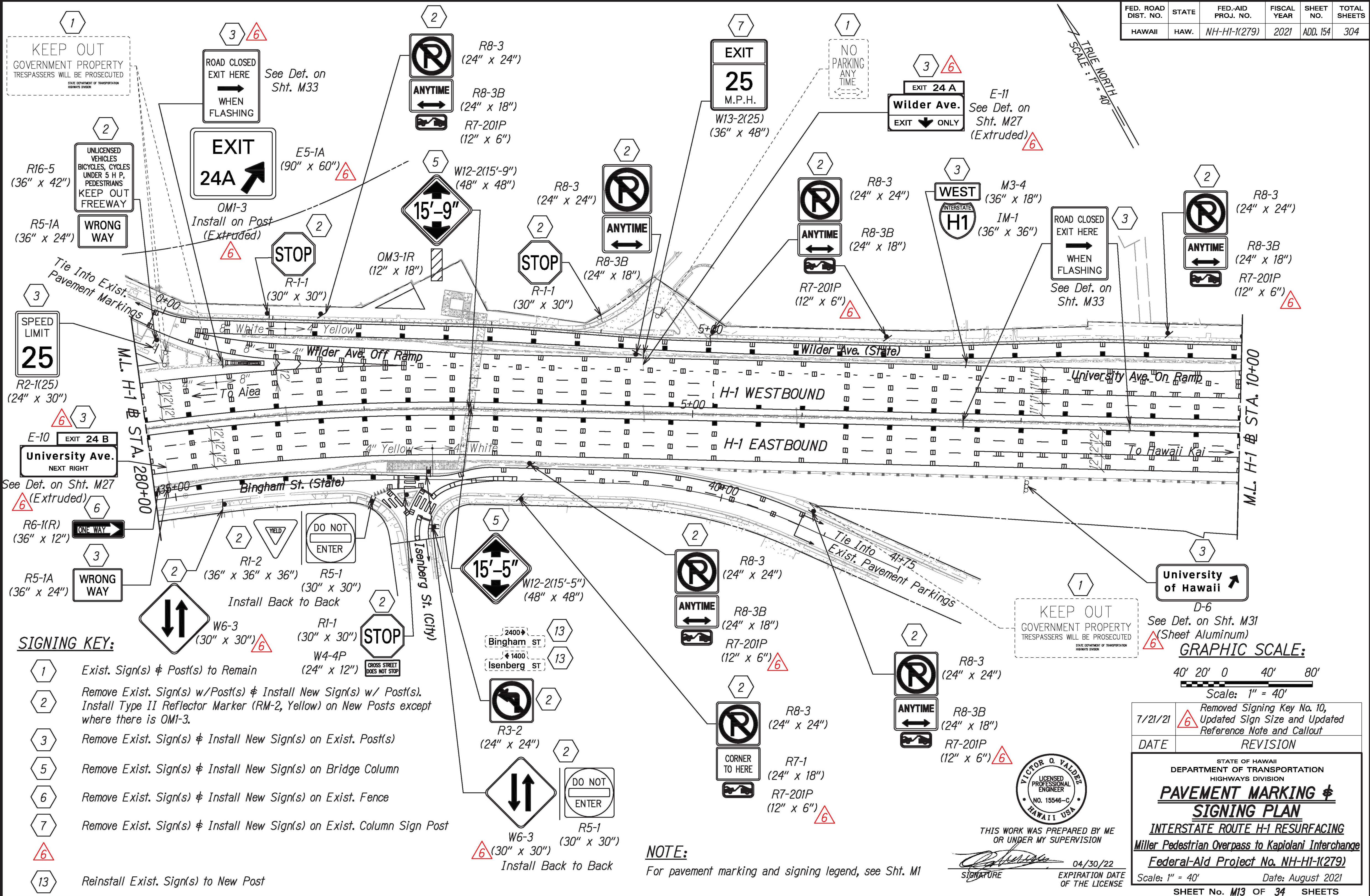

SIGNING KEY:

- 1 Exist. Sign(s) & Post(s) to Remain
- 2 Remove Exist. Sign(s) w/ Post(s) & Install New Sign(s) w/ Post(s). Install Type II Reflector Marker (RM-2, Yellow) on New Posts except where there is OMI-3.
- 3 Remove Exist. Sign(s) & Install New Sign(s) on Exist. Post(s)
- 5 Remove Exist. Sign(s) & Install New Sign(s) on Bridge Column
- 6 Remove Exist. Sign(s) & Install New Sign(s) on Exist. Fence
- 7 Remove Exist. Sign(s) & Install New Sign(s) on Exist. Column Sign Post
- 6 Remove Exist. Sign(s) & Install New Sign(s) on Exist. Fence
- 13 Reinstall Exist. Sign(s) to New Post

NOTE:
For pavement marking and signing legend, see Sht. M1

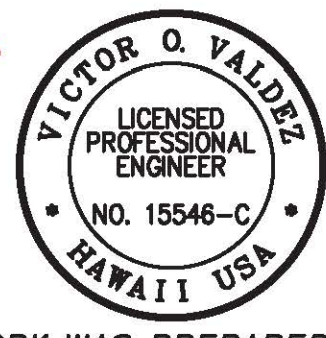

THIS WORK WAS PREPARED BY ME OR UNDER MY SUPERVISION
 SIGNATURE: *[Signature]* 04/30/22
 EXPIRATION DATE OF THE LICENSE

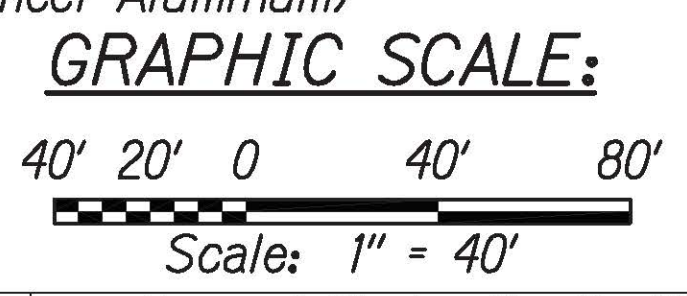

7/21/21	Removed Signing Key No. 10, Updated Sign Size and Updated Reference Note and Callout
DATE	REVISION

STATE OF HAWAII
 DEPARTMENT OF TRANSPORTATION
 HIGHWAYS DIVISION
PAVEMENT MARKING & SIGNING PLAN
 INTERSTATE ROUTE H-1 RESURFACING
 Miller Pedestrian Overpass to Kapiolani Interchange
 Federal-Aid Project No. NH-HI-1(279)
 Scale: 1" = 40' Date: August 2021
 SHEET No. M13 OF 34 SHEETS

C:_CIVIL_3D_PROJECTS\2016_2022\000_DOT-HWYS H1 RESURFACING - MILLER TO KAPITOLI CIVIL DRAWINGS\M2 - M1B - PAVEMENT MARKING AND SIGNING PLANS.DWG 7/22/2021 7:50 AM

FED. ROAD DIST. NO.	STATE	FED-AID PROJ. NO.	FISCAL YEAR	SHEET NO.	TOTAL SHEETS
HAWAII	HAW.	NH-HI-1(279)	2021	ADD. 155	304

SIGNING KEY:

2 Remove Exist. Sign(s) w/Post(s) & Install New Sign(s) w/ Post(s). Install Type II Reflector Marker (RM-2, Yellow) on New Posts except where there is OMI-3.

3 Remove Exist. Sign(s) & Install New on Exist. Post(s)

TRUE NORTH
SCALE: 1" = 40'

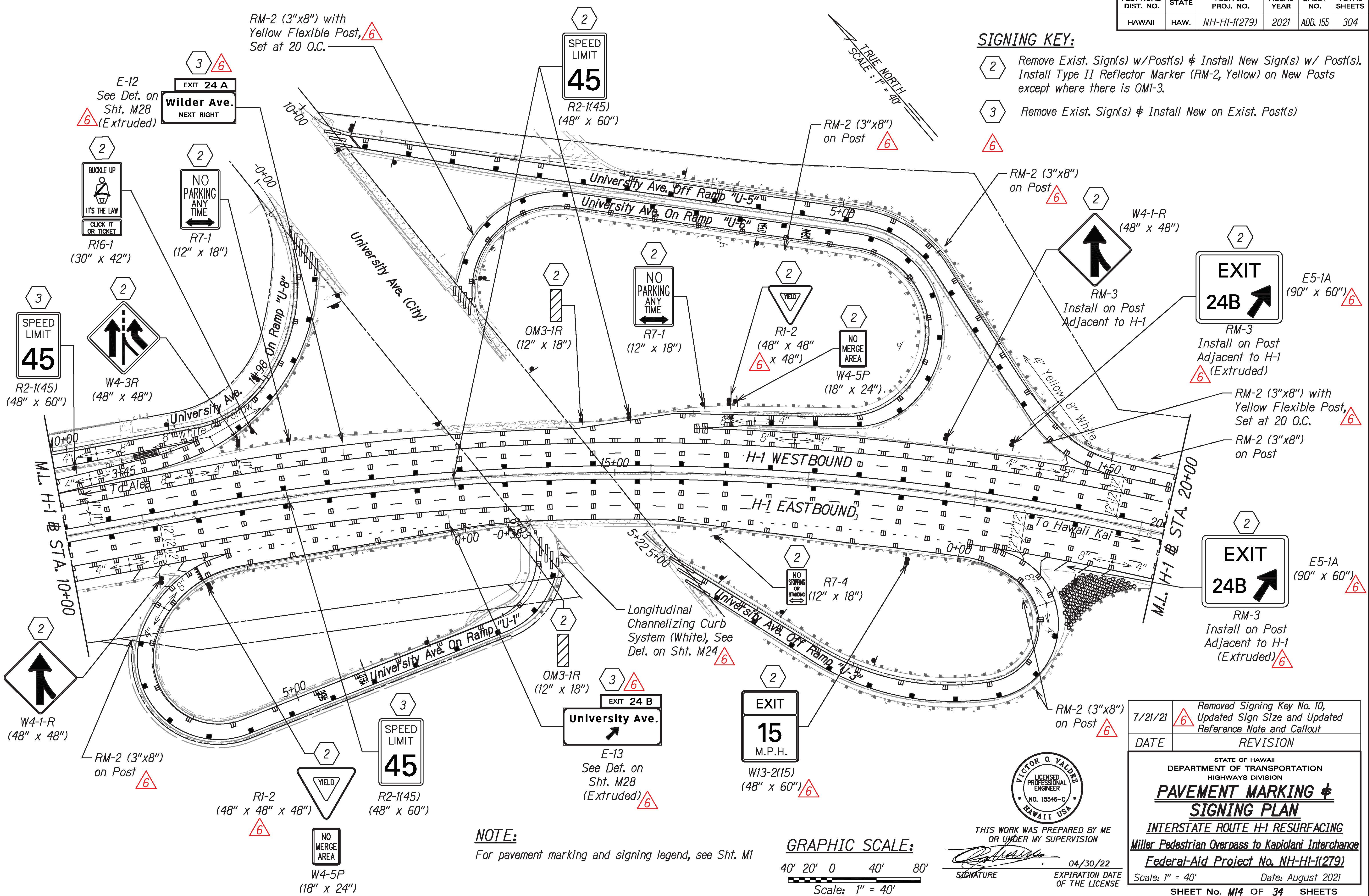

RM-2 (3"x8") with Yellow Flexible Post, Set at 20 O.C.

E-12 See Det. on Sht. M28 (Extruded)

EXIT 24 A NEXT RIGHT

SPEED LIMIT 45 R2-1(45) (48" x 60")

RM-2 (3"x8") on Post

W4-1-R (48" x 48")

EXIT 24B RM-3 Install on Post Adjacent to H-1 (Extruded)

RM-3 Install on Post Adjacent to H-1 (Extruded)

RM-2 (3"x8") with Yellow Flexible Post, Set at 20 O.C. RM-2 (3"x8") on Post

EXIT 24B RM-3 Install on Post Adjacent to H-1 (Extruded)

Longitudinal Channelizing Curb System (White), See Det. on Sht. M24

EXIT 24 B University Ave.

EXIT 15 M.P.H. W13-2(15) (48" x 60")

E-13 See Det. on Sht. M28 (Extruded)

SPEED LIMIT 45 R2-1(45) (48" x 60")

R1-2 (48" x 48" x 48")

NO MERGE AREA W4-5P (18" x 24")

NOTE:
For pavement marking and signing legend, see Sht. M1

GRAPHIC SCALE:
40' 20' 0 40' 80'
Scale: 1" = 40'

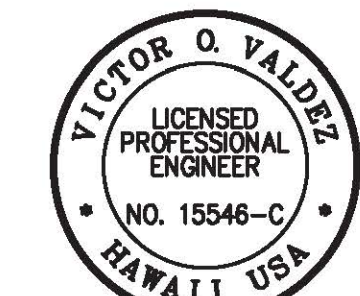

THIS WORK WAS PREPARED BY ME OR UNDER MY SUPERVISION
SIGNATURE: [Signature] 04/30/22 EXPIRATION DATE OF THE LICENSE

DATE	REVISION
7/21/21	Removed Signing Key No. 10, Updated Sign Size and Updated Reference Note and Callout

STATE OF HAWAII
DEPARTMENT OF TRANSPORTATION
HIGHWAYS DIVISION

PAVEMENT MARKING & SIGNING PLAN

INTERSTATE ROUTE H-1 RESURFACING
Miller Pedestrian Overpass to Kapiolani Interchange
Federal-Aid Project No. NH-HI-1(279)

Scale: 1" = 40' Date: August 2021

SHEET No. M14 OF 34 SHEETS

C:_CIVIL_3D_PROJECTS\2016_2022\000_DOT-HWYS_H1_RESURFACING - MILLER TO KAPOLANI CIVIL DRAWINGS\M2 - M18 - PAVEMENT MARKING AND SIGNING PLANS.DWG 7/28/2021 11:14 PM

FED. ROAD DIST. NO.	STATE	FED. AID PROJ. NO.	FISCAL YEAR	SHEET NO.	TOTAL SHEETS
HAWAII	HAW.	NH-H1-1(279)	2021	ADD. 156	304

- SIGNING KEY:**
- 1 Exist. Sign(s) & Post(s) to Remain
 - 2 Remove Exist. Sign(s) w/ Post(s) & Install New Sign(s) w/ Post(s). Install Type II Reflector Marker (RM-2, Yellow) on New Posts except where there is OMI-3.
 - 3 Remove Exist. Sign(s) & Install New on Exist. Post(s)



UNIVERSITY OF HAWAII
COLLEGE OF TROPICAL AGRICULTURE
AND HUMAN RESOURCES
NATIVE HAWAIIAN HYDROSEED
EXPERIMENT FOR FUTURE DOT
ROADSIDE PROJECTS
DR. JOE DEFRANK
EMAIL - defrank@hawaii.edu

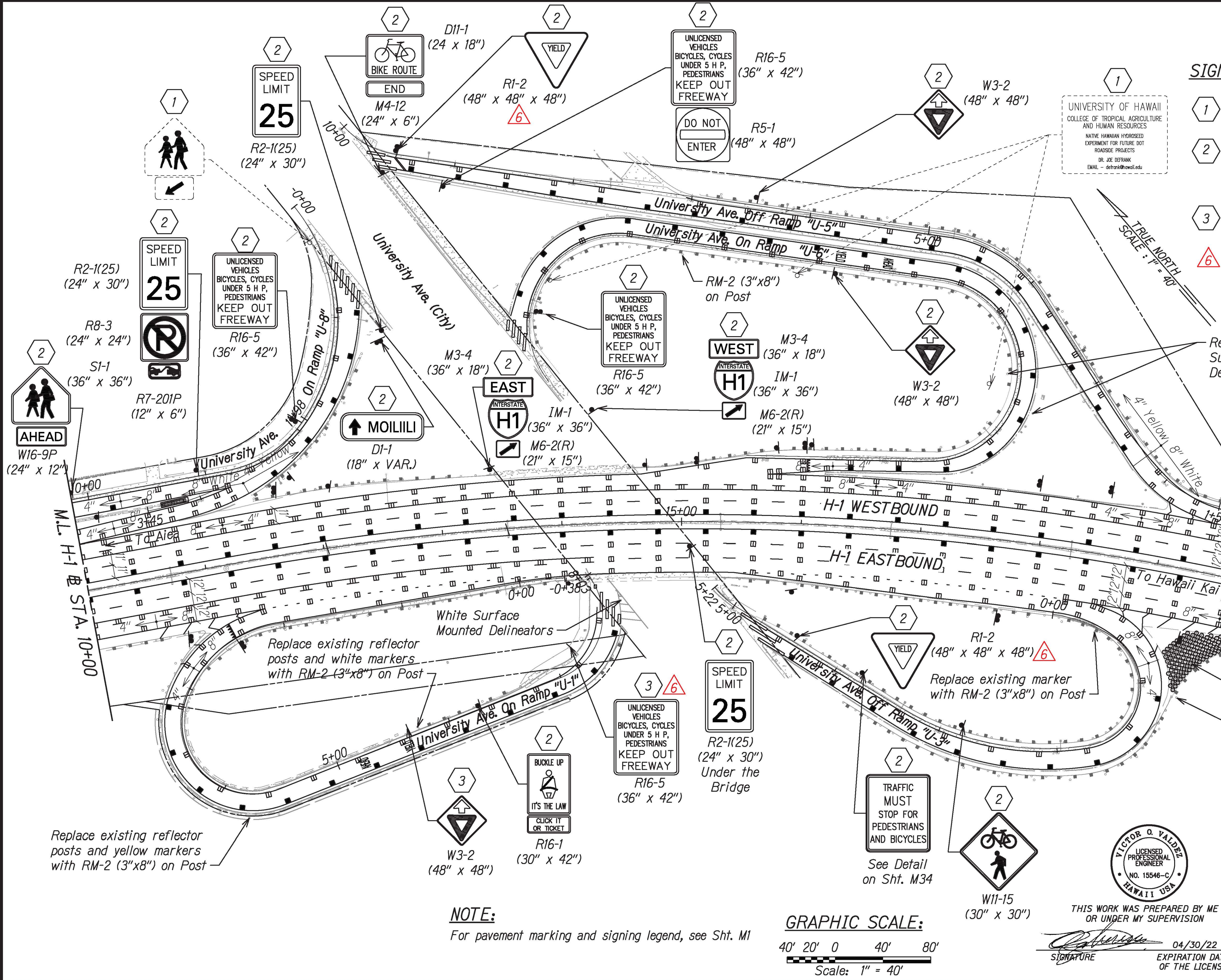

7/21/21	Removed Signing Key No. 10, Updated Sign Size and Updated Reference Note and Callout
DATE	REVISION

STATE OF HAWAII
DEPARTMENT OF TRANSPORTATION
HIGHWAYS DIVISION

PAVEMENT MARKING & SIGNING PLAN

INTERSTATE ROUTE H-1 RESURFACING
Miller Pedestrian Overpass to Kapiolani Interchange
Federal-Aid Project No. NH-H1-1(279)

Scale: 1" = 40' Date: August 2021

SHEET No. M15 OF 34 SHEETS

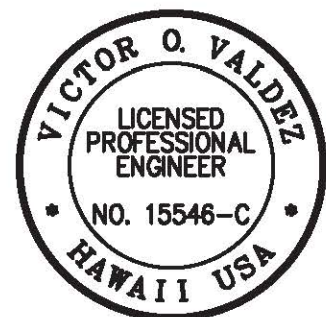

THIS WORK WAS PREPARED BY ME OR UNDER MY SUPERVISION

SIGNATURE: *[Signature]* 04/30/22
EXPIRATION DATE OF THE LICENSE

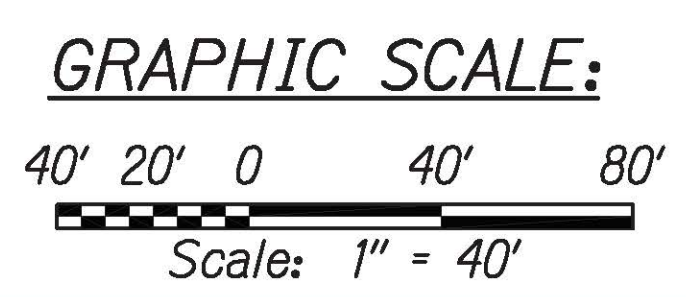

NOTE:
For pavement marking and signing legend, see Sht. M1

C:_3D PROJECTS\2016_2022\000_DOT-HWYS H1 RESURFACING - MILLER TO KAPANIYOI CIVIL DRAWINGS\M2 - M18 - PAVEMENT MARKING AND SIGNING PLANS.DWG 7/22/2021 7:50 AM

FED. ROAD DIST. NO.	STATE	FED. AID PROJ. NO.	FISCAL YEAR	SHEET NO.	TOTAL SHEETS
HAWAII	HAW.	NH-H1-1(279)	2021	ADD. 157	304

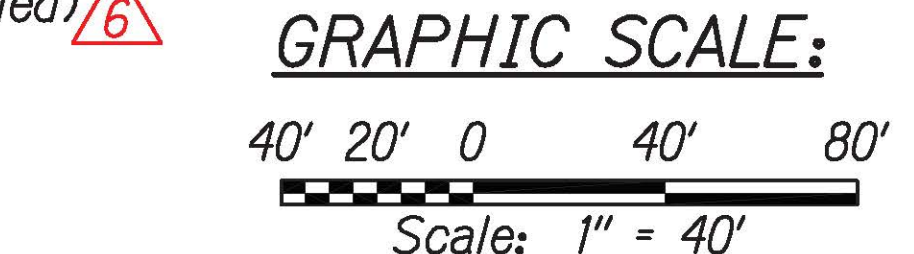
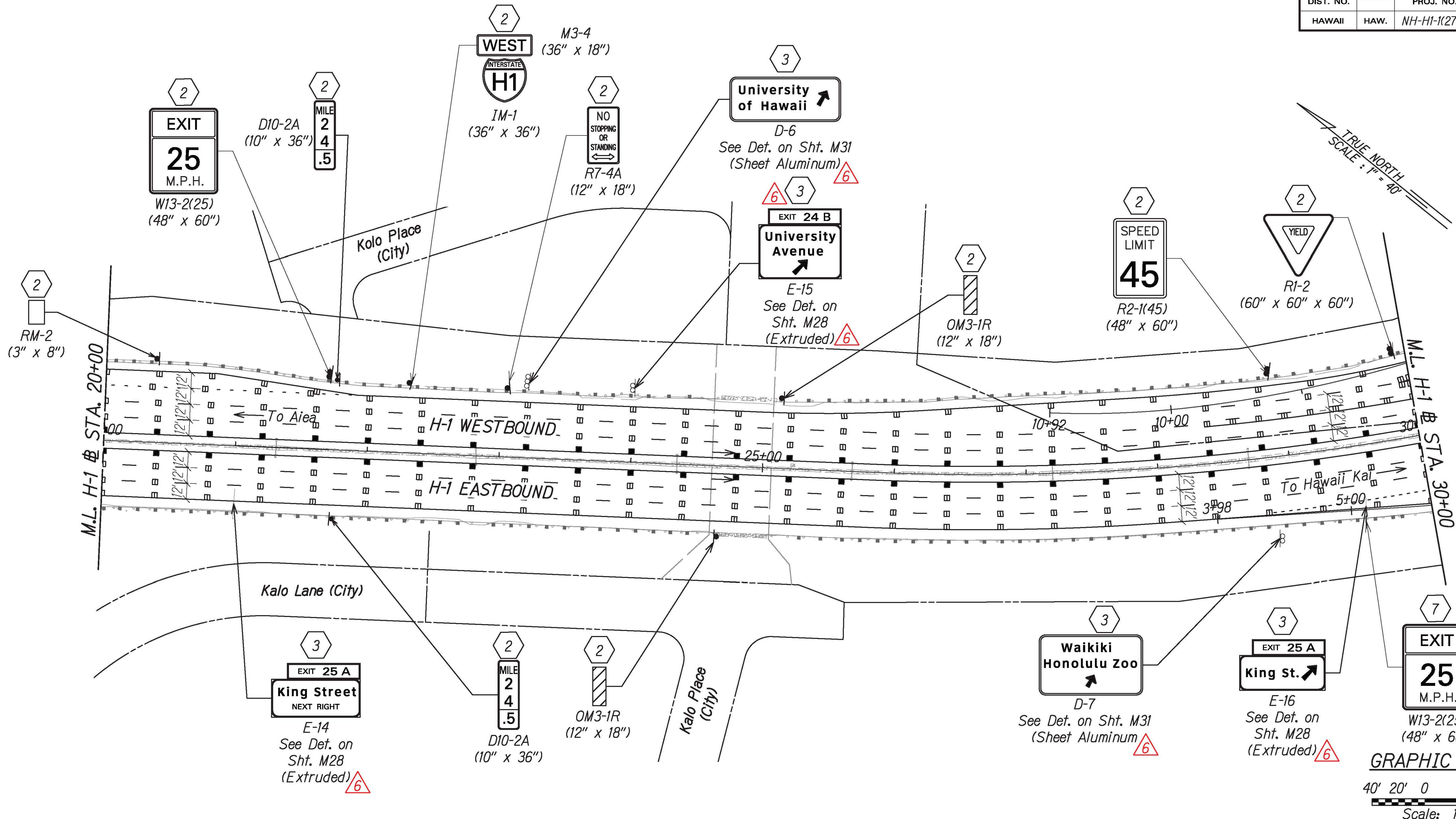

NOTE:
For pavement marking and signing legend, see Sht. M1

- SIGNING KEY:**
- ② Remove Exist. Sign(s) w/Post(s) & Install New Sign(s) w/ Post(s).
Install Type II Reflector Marker (RM-2, Yellow) on New Posts except where there is OMI-3.
 - ③ Remove Exist. Sign(s) & Install New Sign(s) on Exist. Post(s)
 - ⑦ Remove Exist. Sign(s) & Install New Sign(s) on Exist. Column Sign Post
 - ⚠️ Remove Existing Sign

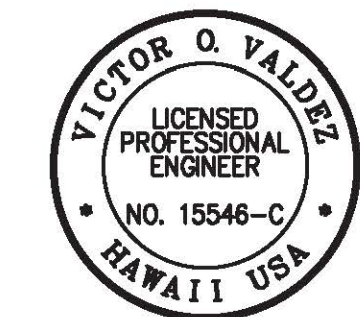

THIS WORK WAS PREPARED BY ME
OR UNDER MY SUPERVISION

Victor O. Valdez
SIGNATURE

04/30/22
EXPIRATION DATE
OF THE LICENSE

7/21/21	⚠️	Removed Signing Key No. 10, Updated Sign Size and Updated Reference Note and Callout
DATE		REVISION
STATE OF HAWAII DEPARTMENT OF TRANSPORTATION HIGHWAYS DIVISION PAVEMENT MARKING & SIGNING PLAN INTERSTATE ROUTE H-1 RESURFACING Miller Pedestrian Overpass to Kapiolani Interchange Federal-Aid Project No. NH-H1-1(279) Scale: 1" = 40' Date: August 2021		
SHEET No. M16 OF 34 SHEETS		

C:_CIVIL_3D_PROJECTS\2016_2021\000_DOT-HWYS H1_RESURFACING - MILLER TO KAPITANI\01_CIVIL_DRAWINGS\M2 - M16_PAVEMENT MARKING AND SIGNING PLANS.DWG 7/22/2021 7:59 AM

FED. ROAD DIST. NO.	STATE	FED-AID PROJ. NO.	FISCAL YEAR	SHEET NO.	TOTAL SHEETS
HAWAII	HAW.	NH-H1-1(279)	2021	ADD. 158	304

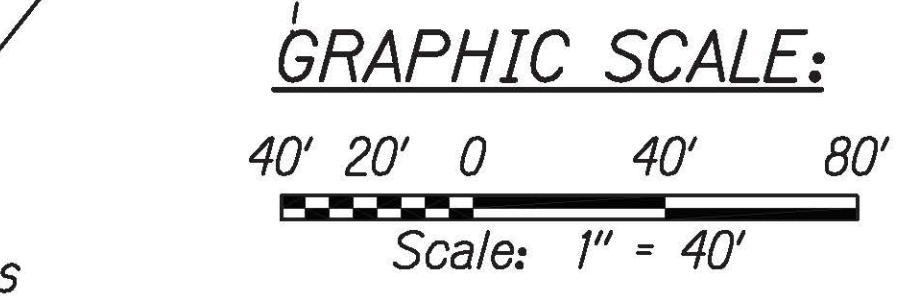
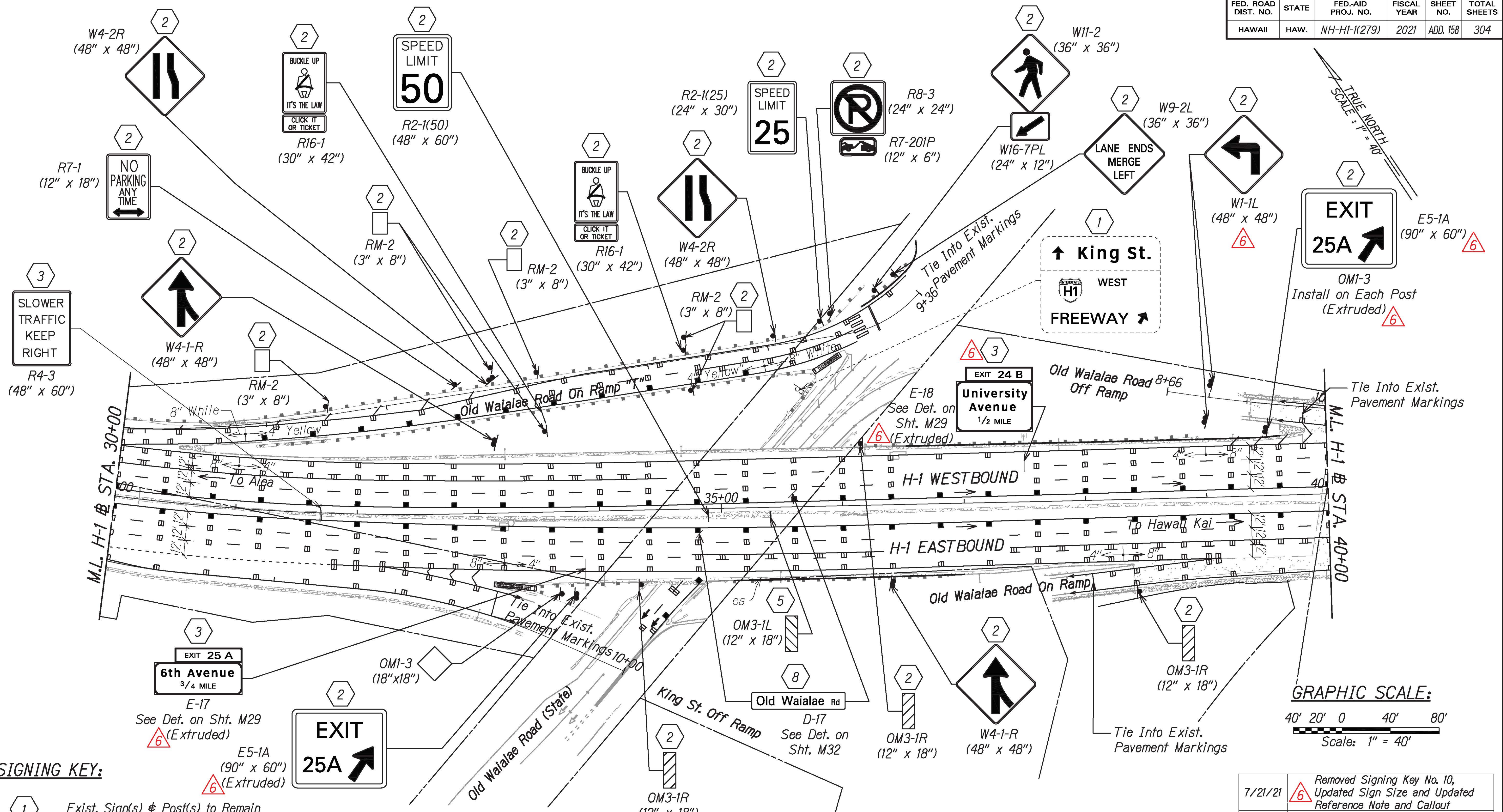

SIGNING KEY:

- 1 Exist. Sign(s) & Post(s) to Remain
- 2 Remove Exist. Sign(s) w/Post(s) & Install New Sign(s) w/ Post(s). Install Type II Reflector Marker (RM-2, Yellow) on New Posts except where there is OMI-3.
- 3 Remove Exist. Sign(s) & Install New Sign(s) on Exist. Post(s)
- 5 Remove Exist. Sign(s) & Install New Sign(s) on Bridge Column
- 8 Remove Exist. Sign(s) & Install New Sign Mounted on Overpass (Bridge) Fascia

NOTE:
For pavement marking and signing legend, see Sht. M1

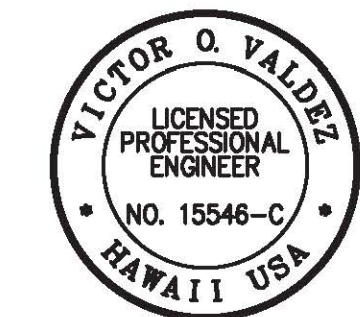

THIS WORK WAS PREPARED BY ME OR UNDER MY SUPERVISION
 SIGNATURE: [Signature] 04/30/22
 EXPIRATION DATE OF THE LICENSE

7/21/21	Removed Signing Key No. 10, Updated Sign Size and Updated Reference Note and Callout
DATE	REVISION
STATE OF HAWAII DEPARTMENT OF TRANSPORTATION HIGHWAYS DIVISION PAVEMENT MARKING & SIGNING PLAN INTERSTATE ROUTE H-1 RESURFACING Miller Pedestrian Overpass to Kapiolani Interchange Federal-Aid Project No. NH-H1-1(279) Scale: 1" = 40' Date: August 2021	
SHEET No. M17 OF 34 SHEETS	

C:_CIVIL_3D_PROJECTS\2016_2022\000_DOT-HWYS H1-RESURFACING - MILLER TO KAPITANI\01_CIVIL DRAWINGS\M2 - M18_PAVEMENT MARKING AND SIGNING PLANS.DWG 7/22/2021 10:26 AM

FED. ROAD DIST. NO.	STATE	FED-AID PROJ. NO.	FISCAL YEAR	SHEET NO.	TOTAL SHEETS
HAWAII	HAW.	NH-H1-1(279)	2021	ADD. 159	304

TRUE NORTH
SCALE: 1" = 40'

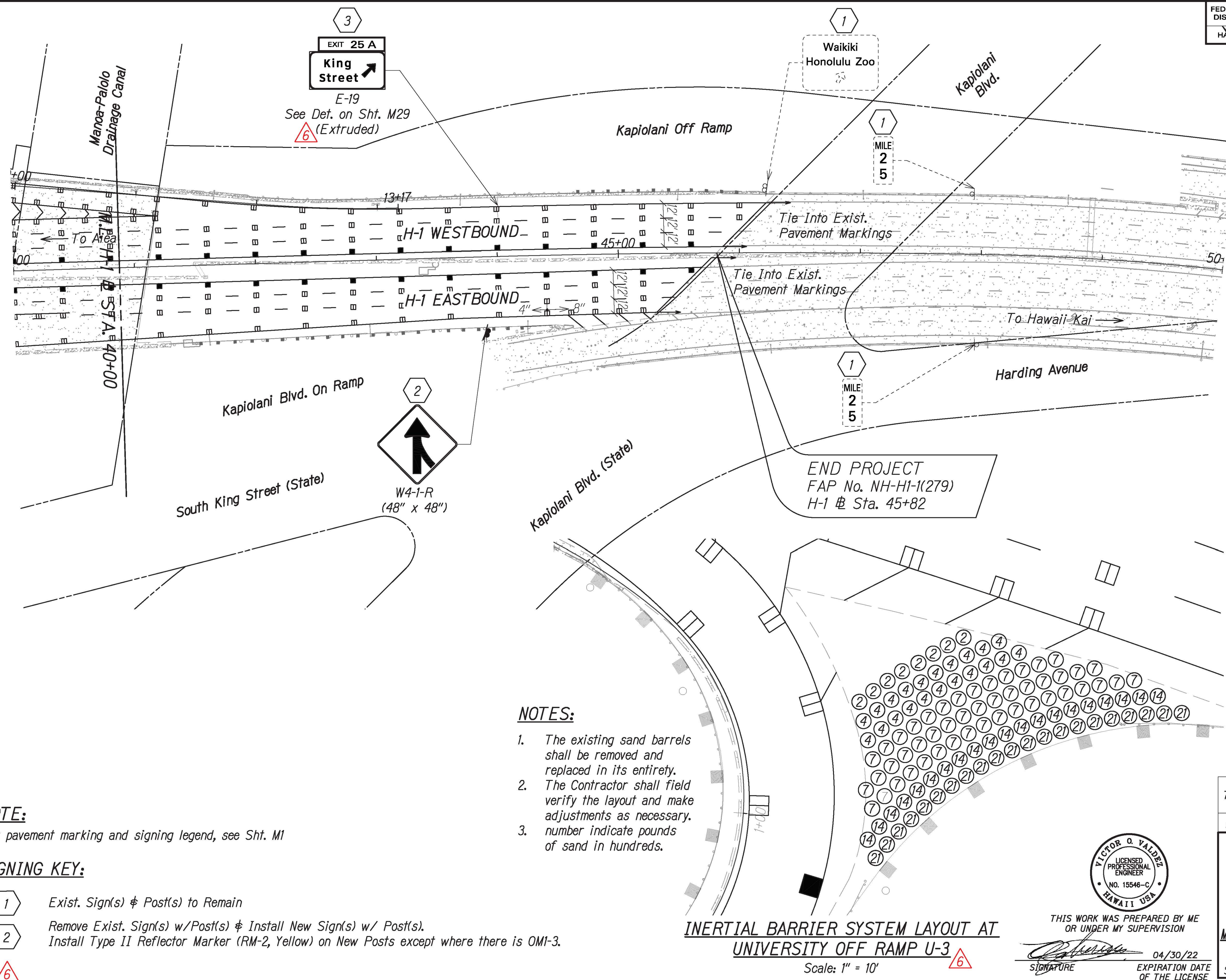

C:_CIVIL_3D_PROJECTS\2016_2022\000_DOT-HWYS H1 RESURFACING - MILLER TO K4PNTY01 CIVIL DRAWINGS\M2 - M18 PAVEMENT MARKING AND SIGNING PLANS.DWG 7/22/2021 8:07 AM

NOTE:

For pavement marking and signing legend, see Sht. M1

SIGNING KEY:

- 1 Exist. Sign(s) & Post(s) to Remain
- 2 Remove Exist. Sign(s) w/Post(s) & Install New Sign(s) w/ Post(s).
Install Type II Reflector Marker (RM-2, Yellow) on New Posts except where there is OMI-3.
- 6

NOTES:

1. The existing sand barrels shall be removed and replaced in its entirety.
2. The Contractor shall field verify the layout and make adjustments as necessary.
3. number indicate pounds of sand in hundreds.

INERTIAL BARRIER SYSTEM LAYOUT AT UNIVERSITY OFF RAMP U-3

Scale: 1" = 10'

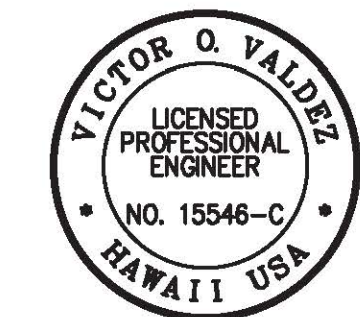

THIS WORK WAS PREPARED BY ME OR UNDER MY SUPERVISION
 SIGNATURE: [Signature] 04/30/22
 EXPIRATION DATE OF THE LICENSE

GRAPHIC SCALE:

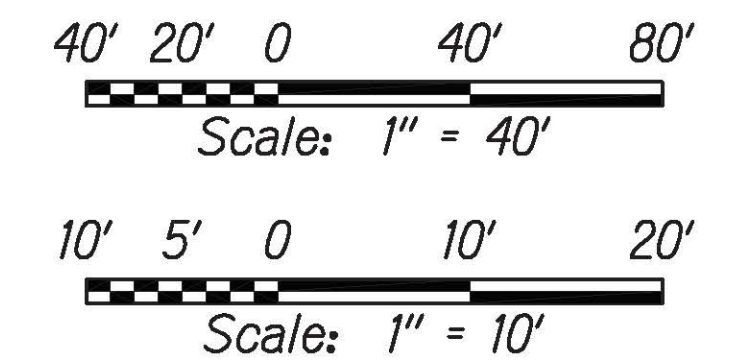

7/21/21	6	Added Barrier Sytem Layout, Removed Signing Key No. 10 and Updated Reference Note
DATE		REVISION

STATE OF HAWAII
 DEPARTMENT OF TRANSPORTATION
 HIGHWAYS DIVISION
PAVEMENT MARKING & SIGNING PLAN
 INTERSTATE ROUTE H-1 RESURFACING
 Miller Pedestrian Overpass to Kapiolani Interchange
 Federal-Aid Project No. NH-H1-1(279)
 Scale: 1" = 40' Date: August 2021

FED. ROAD DIST. NO.	STATE	FED-AID PROJ. NO.	FISCAL YEAR	SHEET NO.	TOTAL SHEETS
HAWAII	HAW.	NH-H1-1(279)	2021	ADD. 160	304

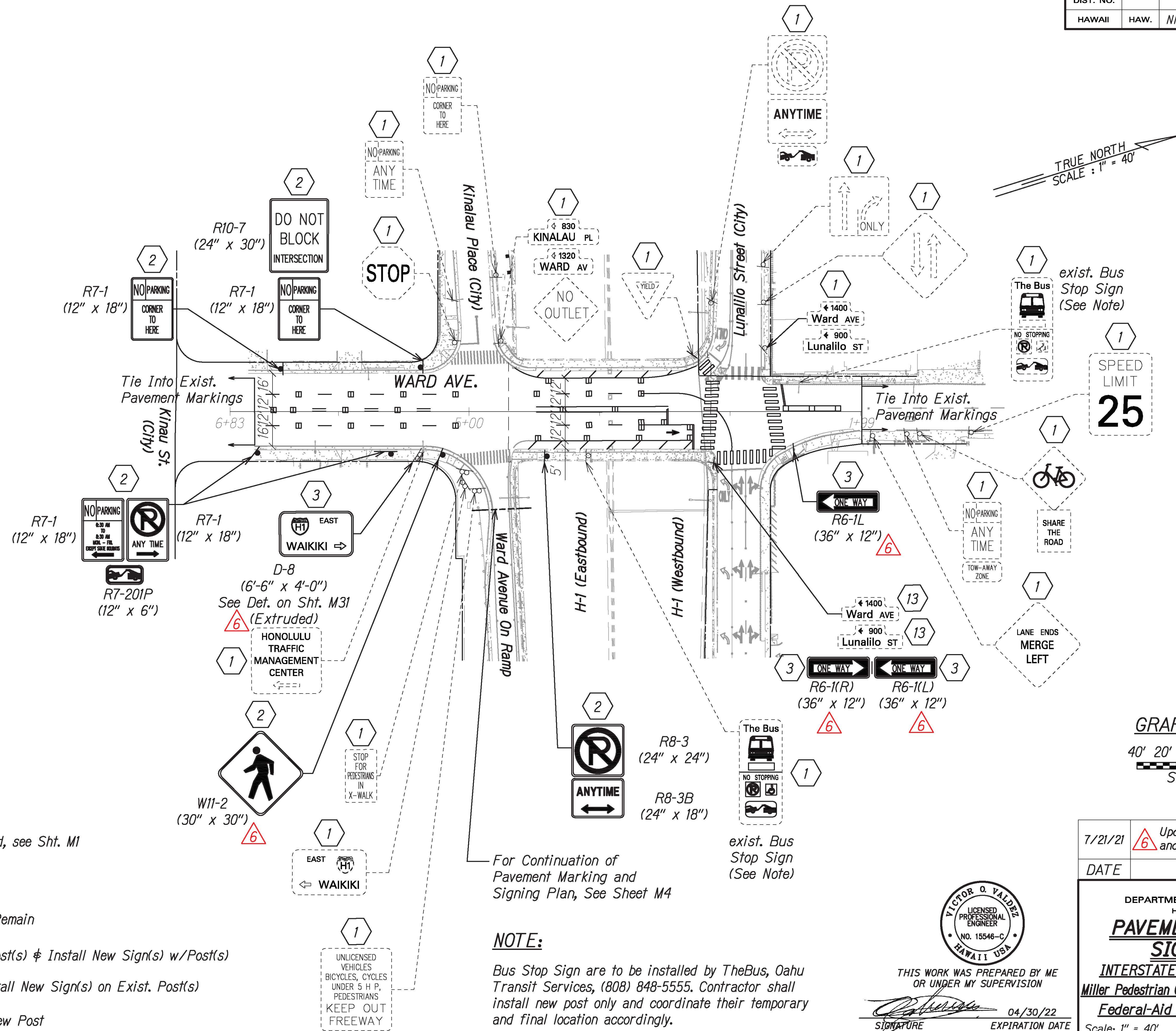

NOTE:
For pavement marking and signing legend, see Sht. M1

SIGNING KEY:

- 1 Exist. Sign(s) & Post(s) to Remain
- 2 Remove Exist. Sign(s) w/ Post(s) & Install New Sign(s) w/Post(s)
- 3 Remove Exist. Sign(s) & Install New Sign(s) on Exist. Post(s)
- 13 Reinstall Exist. Sign(s) to New Post

NOTE:
Bus Stop Sign are to be installed by TheBus, Oahu Transit Services, (808) 848-5555. Contractor shall install new post only and coordinate their temporary and final location accordingly.

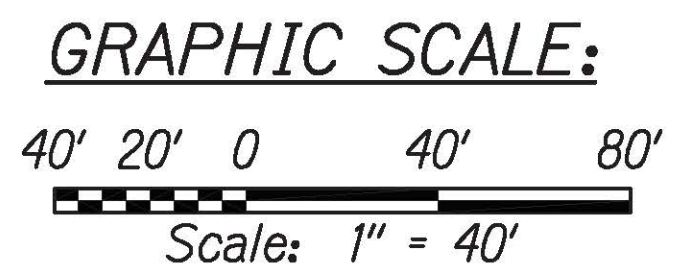

7/21/21	Updated Sign Description and Updated Sign Size
DATE	REVISION
STATE OF HAWAII DEPARTMENT OF TRANSPORTATION HIGHWAYS DIVISION PAVEMENT MARKING & SIGNING PLAN INTERSTATE ROUTE H-1 RESURFACING Miller Pedestrian Overpass to Kapiolani Interchange Federal-Aid Project No. NH-H1-1(279)	
Scale: 1" = 40'	Date: August 2021
SHEET No. M19 OF 34 SHEETS	



THIS WORK WAS PREPARED BY ME OR UNDER MY SUPERVISION
 SIGNATURE: *[Signature]* 04/30/22
 EXPIRATION DATE OF THE LICENSE

C:_CIVIL_3D_PROJECTS\2016_2022\000_DOT-HWYS H1-RESURFACING - MILLER TO KAPIOLANI CIVIL DRAWINGS\M19 - M24 - PAVEMENT MARKING AND SIGNING PLANS.DWG 7/22/2021 4:38 AM

FED. ROAD DIST. NO.	STATE	FED-AID PROJ. NO.	FISCAL YEAR	SHEET NO.	TOTAL SHEETS
HAWAII	HAW.	NH-HI-1(279)	2021	ADD.161	304

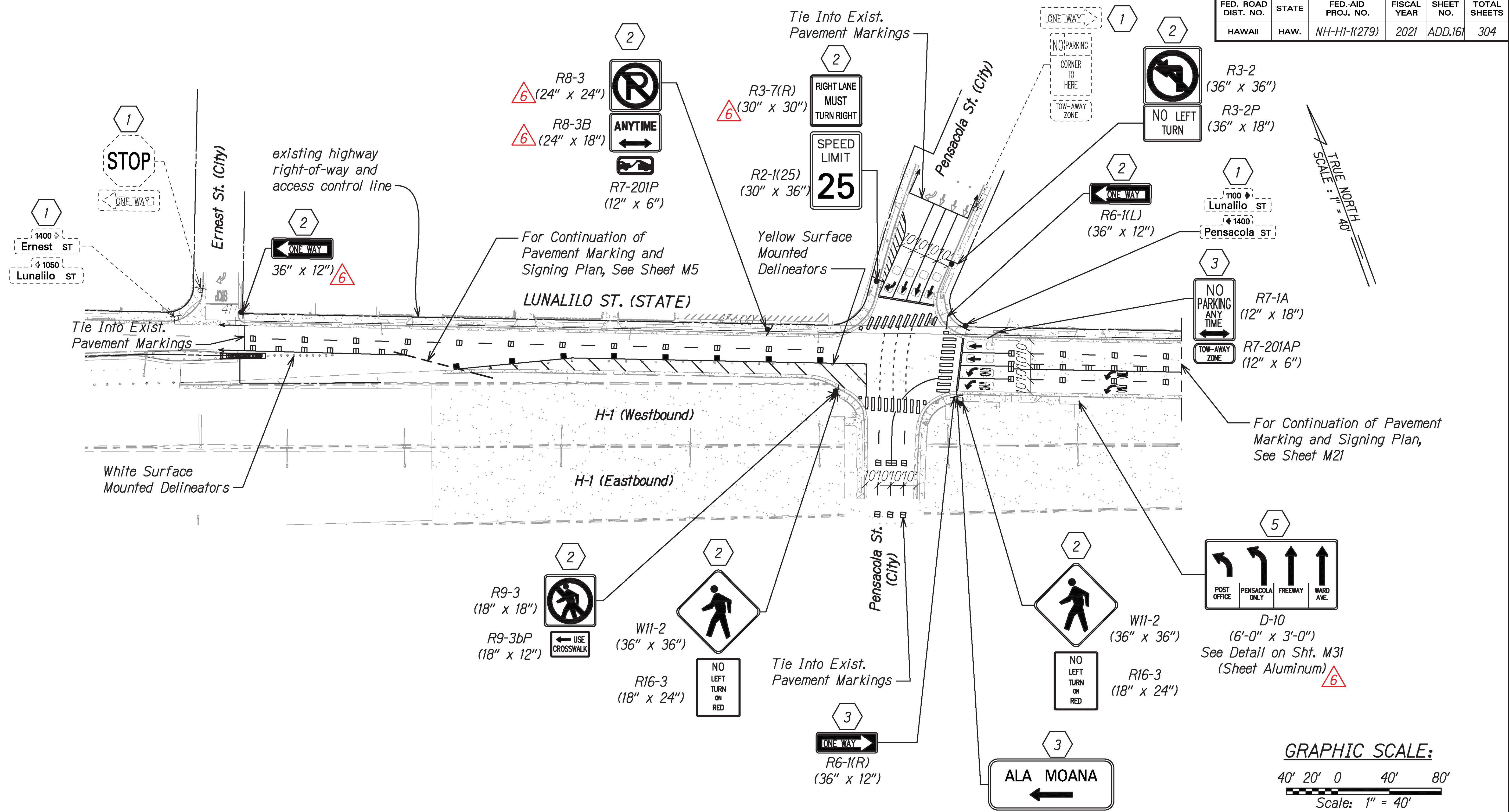

TRUE NORTH
SCALE: 1" = 40'

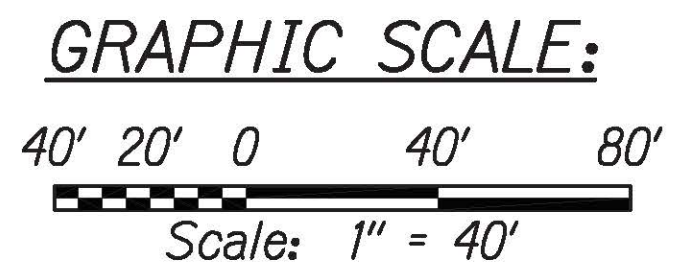

NOTE:
For pavement marking and signing legend, see Sht. M1

SIGNING KEY:

- 1 Exist. Sign(s) & Post(s) to Remain
- 2 Remove Exist. Sign(s) w/ Post(s) & Install New Sign(s) w/Post(s). Install Type II Reflector Marker (RM-2, Yellow) on New Post(s).
- 3 Remove Exist. Sign(s) & Install New Sign(s) on Exist. Post(s)
- 5 Remove Exist. Sign(s) & Install New Sign(s) on Bridge Column

D-9
(48" x 24")
See Detail on Sht. M31
△6 (Sheet Aluminum)

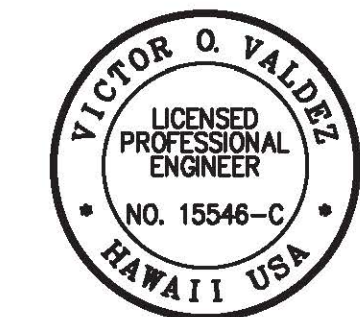

THIS WORK WAS PREPARED BY ME OR UNDER MY SUPERVISION
SIGNATURE: [Signature] 04/30/22
EXPIRATION DATE OF THE LICENSE

7/21/21	△6 Updated Sign Description and Updated Sign Size
DATE	REVISION
STATE OF HAWAII DEPARTMENT OF TRANSPORTATION HIGHWAYS DIVISION PAVEMENT MARKING & SIGNING PLAN INTERSTATE ROUTE H-1 RESURFACING Miller Pedestrian Overpass to Kapiolani Interchange Federal-Aid Project No. NH-HI-1(279) Scale: 1" = 40' Date: August 2021	
SHEET No. M20 OF 34 SHEETS	

C:_CIVIL_3D_PROJECTS\2016_2022\000_DOT-HWYS H1-RESURFACING - MILLER TO KAPITOLI CIVIL DRAWINGS\M19 - M24 - PAVEMENT MARKING AND SIGNING PLANS.DWG 7/22/2021 4:51 AM

FED. ROAD DIST. NO.	STATE	FED-AID PROJ. NO.	FISCAL YEAR	SHEET NO.	TOTAL SHEETS
HAWAII	HAW.	NH-HI-1(279)	2021	ADD. 162	304

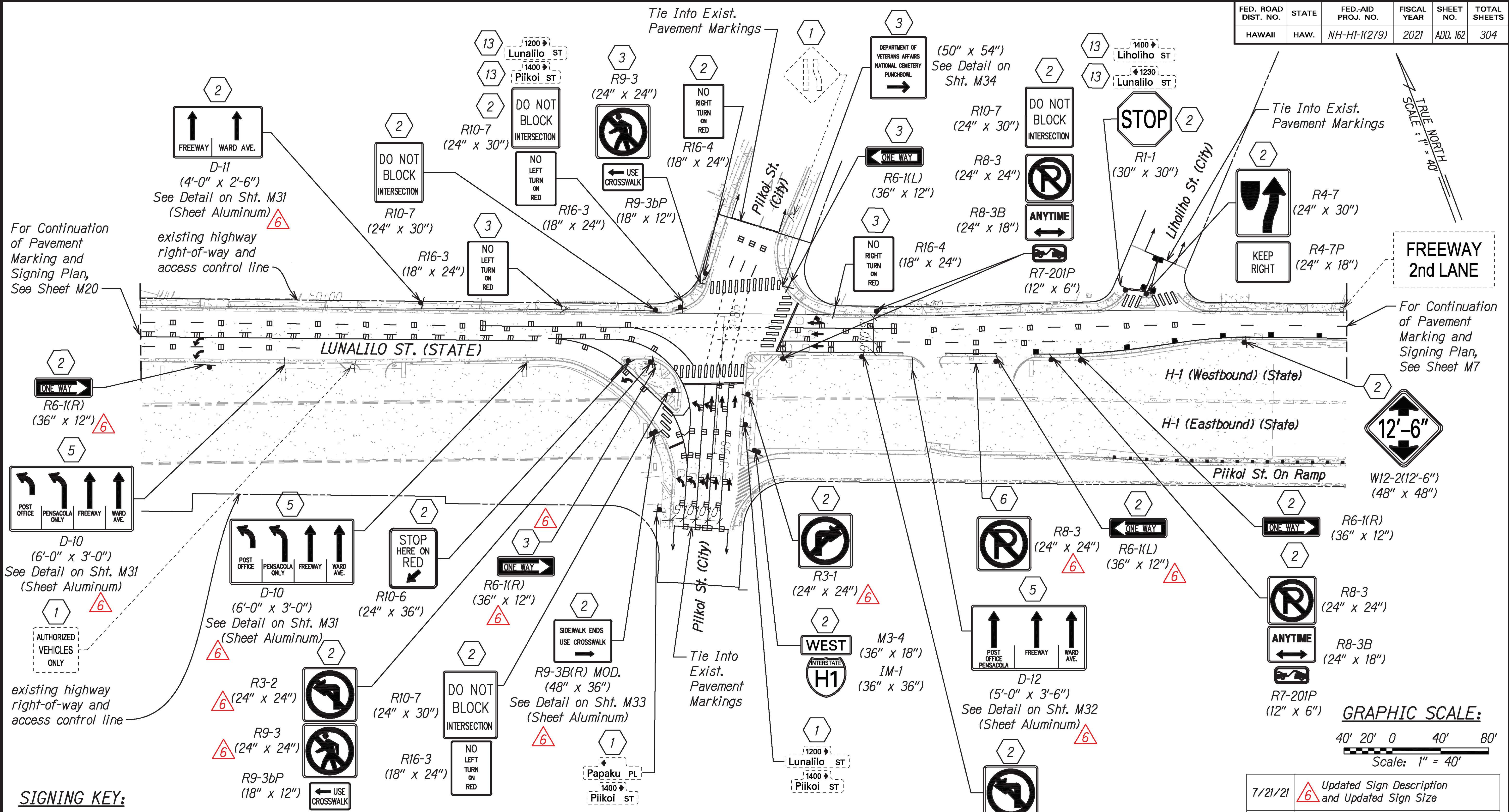

For Continuation of Pavement Marking and Signing Plan, See Sheet M20

For Continuation of Pavement Marking and Signing Plan, See Sheet M7

TRUE NORTH
SCALE: 1" = 40'



SIGNING KEY:

- 1 Exist. Sign(s) & Post(s) to Remain
- 2 Remove Exist. Sign(s) w/ Post(s) & Install New Sign(s) w/Post(s)
Install Type II Reflector Marker (RM-2, Yellow) on New Post(s).
- 3 Remove Exist. Sign(s) & Install New Sign(s) on Exist. Post(s)
- 5 Remove Exist. Sign(s) & Install New Sign(s) on Bridge Column
- 6 Remove Exist. Sign(s) & Install New Sign(s) on Exist. Fence
- 13 Reinstall Exist. Sign(s) to New Post

NOTE:

For pavement marking and signing legend, see Sht. M1



THIS WORK WAS PREPARED BY ME OR UNDER MY SUPERVISION

SIGNATURE: *[Signature]* 04/30/22
EXPIRATION DATE OF THE LICENSE

7/21/21	Updated Sign Description and Updated Sign Size
DATE	REVISION
STATE OF HAWAII DEPARTMENT OF TRANSPORTATION HIGHWAYS DIVISION PAVEMENT MARKING & SIGNING PLAN INTERSTATE ROUTE H-1 RESURFACING Miller Pedestrian Overpass to Kapiolani Interchange Federal-Aid Project No. NH-HI-1(279) Scale: 1" = 40' Date: August 2021 SHEET No. M21 OF 34 SHEETS	

C:_CIVIL_3D_PROJECTS\2016_2022\000_DOT-HWYS H1-RESURFACING - MILLER TO KAPITOLI CIVIL DRAWINGS\M19 - M24 - PAVEMENT MARKING AND SIGNING PLANS.DWG 7/22/2021 4:51 AM

FED. ROAD DIST. NO.	STATE	FED-AID PROJ. NO.	FISCAL YEAR	SHEET NO.	TOTAL SHEETS
HAWAII	HAW.	NH-HI-1(279)	2021	ADD. 164	304

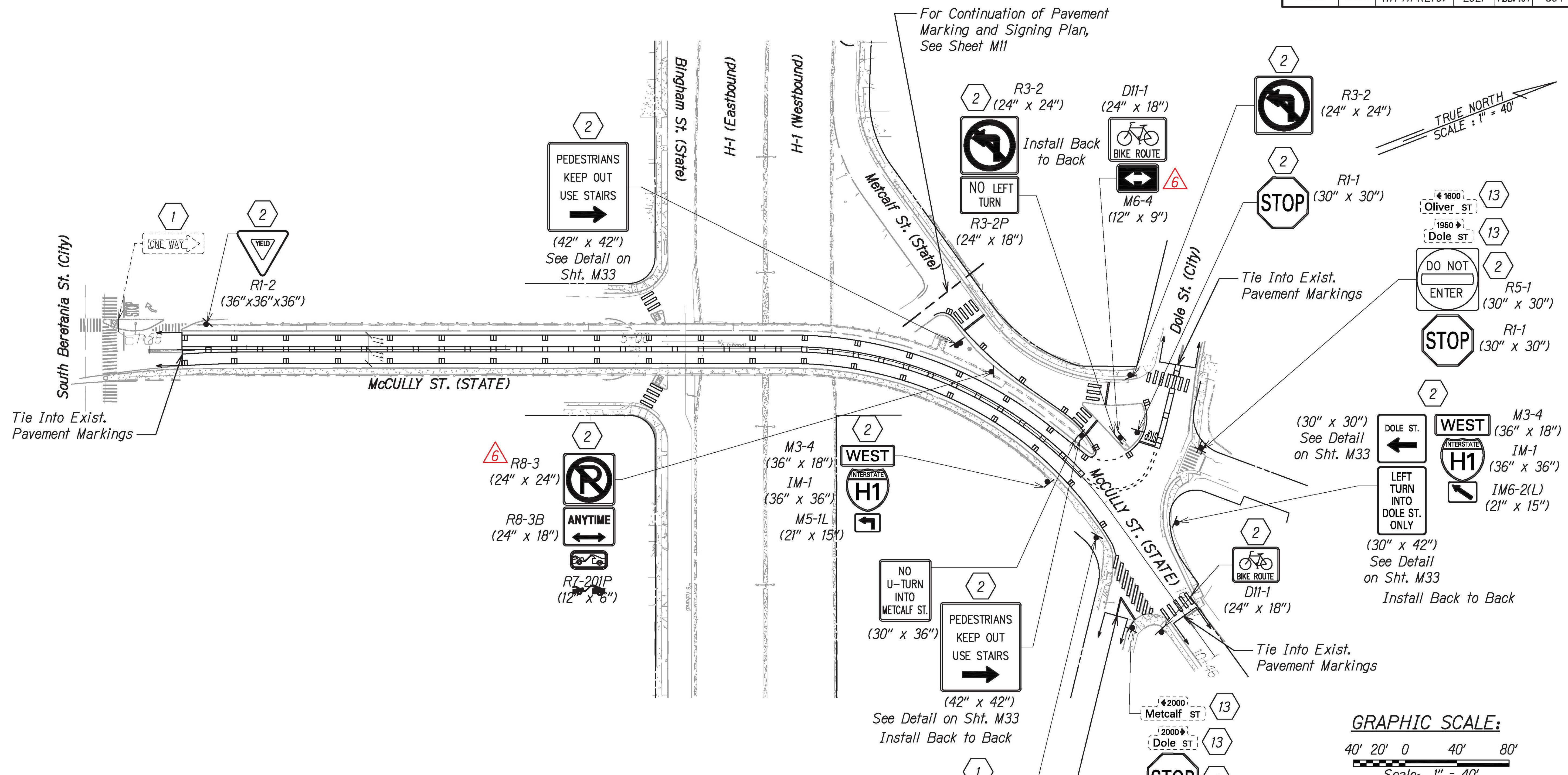

NOTE:
For pavement marking and signing legend, see Sht. M1

SIGNING KEY:

- 1 Exist. Sign(s) & Post(s) to Remain
- 2 Remove Exist. Sign(s) w/ Post(s) & Install New Sign(s) w/Post(s)
Install Type II Reflector Marker (RM-2, Yellow) on New Post(s).
- 13 Reinstall Exist. Sign(s) to New Post

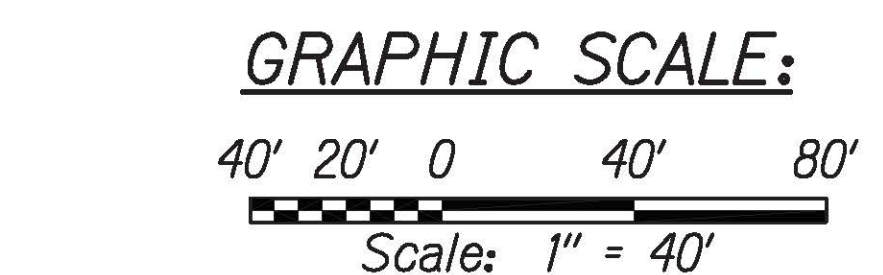

7/21/21	Updated Sign and Description
DATE	REVISION

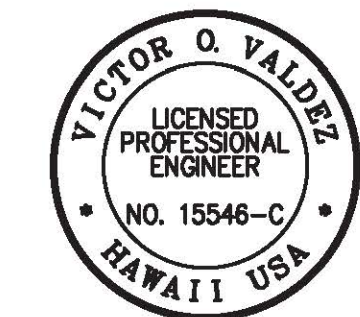

THIS WORK WAS PREPARED BY ME
OR UNDER MY SUPERVISION
[Signature] 04/30/22
SIGNATURE EXPIRATION DATE OF THE LICENSE

STATE OF HAWAII
DEPARTMENT OF TRANSPORTATION
HIGHWAYS DIVISION
PAVEMENT MARKING & SIGNING PLAN
INTERSTATE ROUTE H-1 RESURFACING
Miller Pedestrian Overpass to Kapiolani Interchange
Federal-Aid Project No. NH-HI-1(279)
Scale: 1" = 40' Date: August 2021

C:_CIVIL_3D_PROJECTS\2016_2022\000_DOT-HWYS H1 RESURFACING - MILLER TO KAPITOLI CIVIL DRAWINGS\M19 - M24 - PAVEMENT MARKING AND SIGNING PLANS.DWG 7/22/2021 11:04 AM

FED. ROAD DIST. NO.	STATE	FED. AID PROJ. NO.	FISCAL YEAR	SHEET NO.	TOTAL SHEETS
HAWAII	HAW.	NH-H1-1(279)	2021	ADD. 165	304

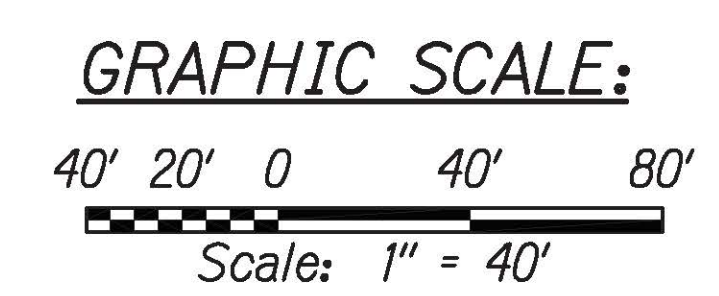
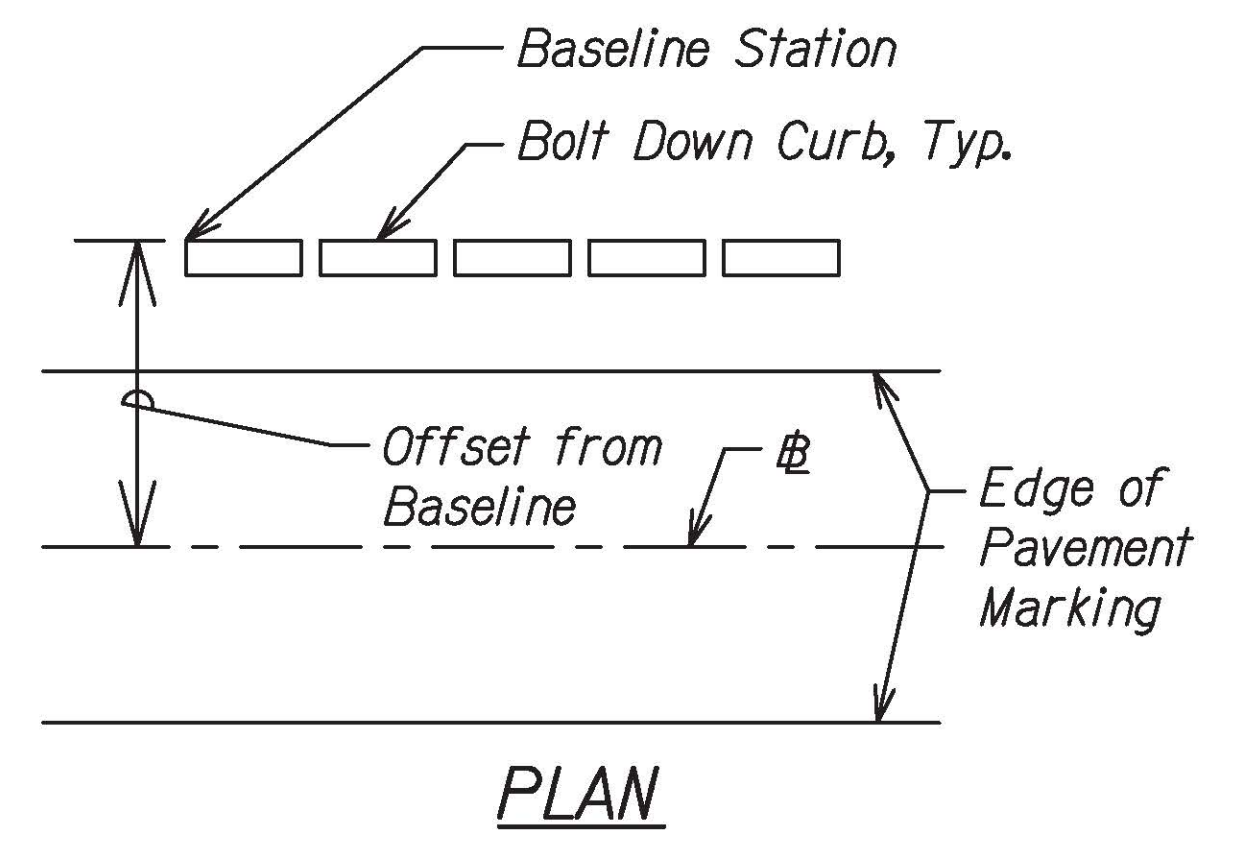
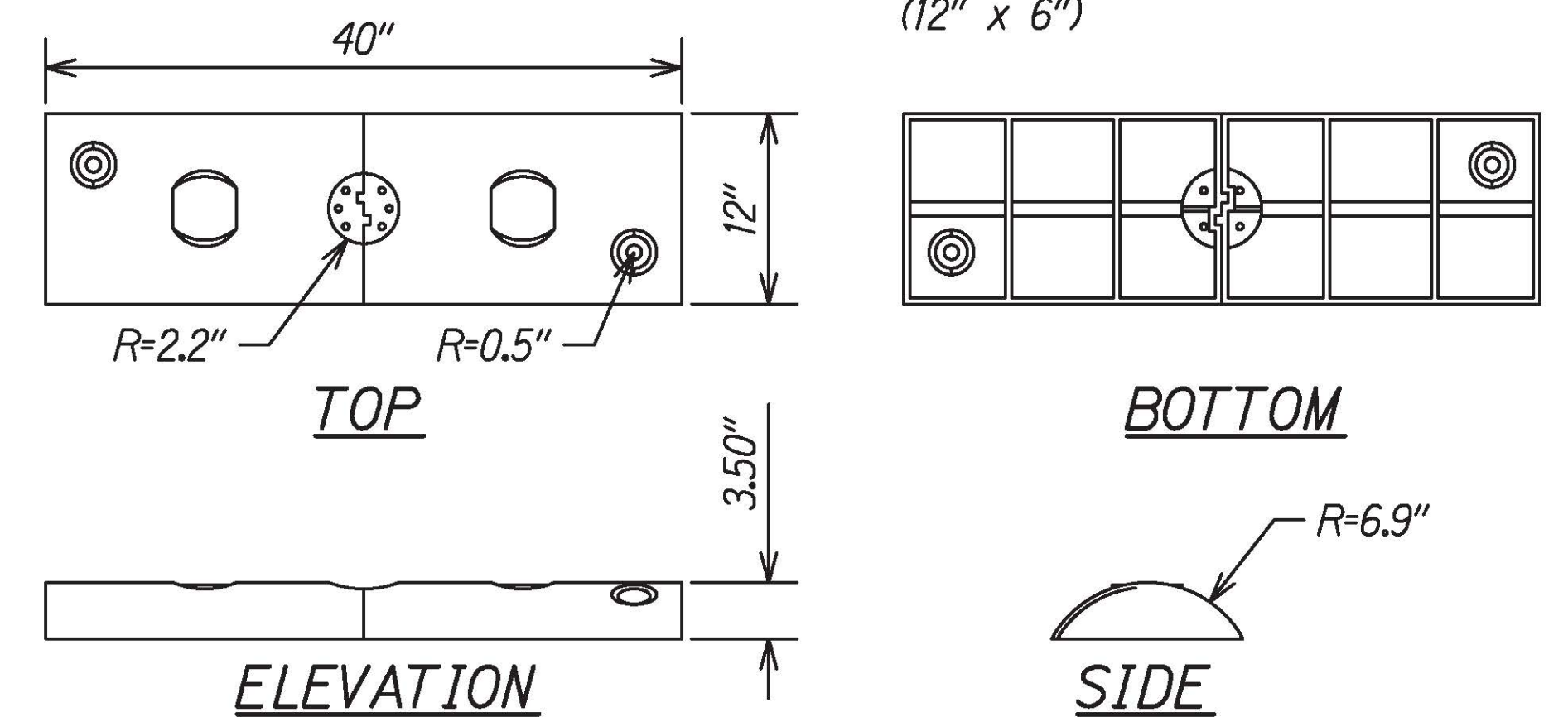
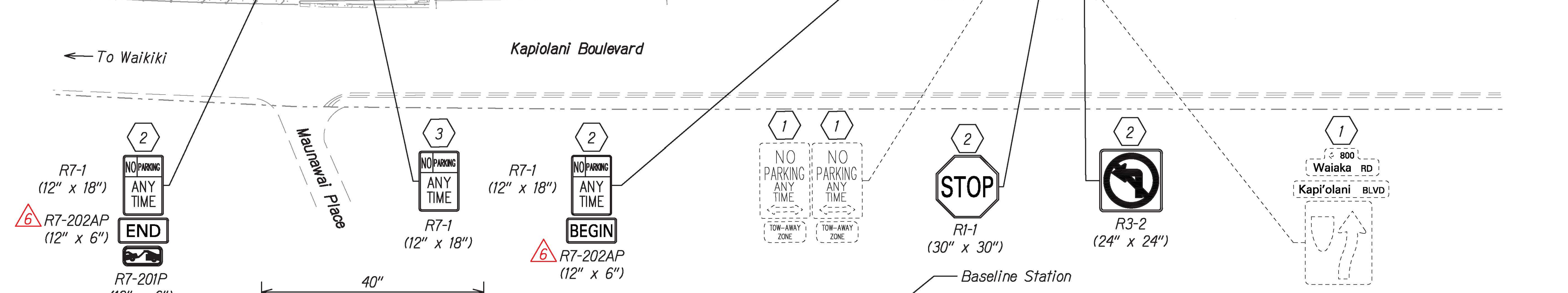
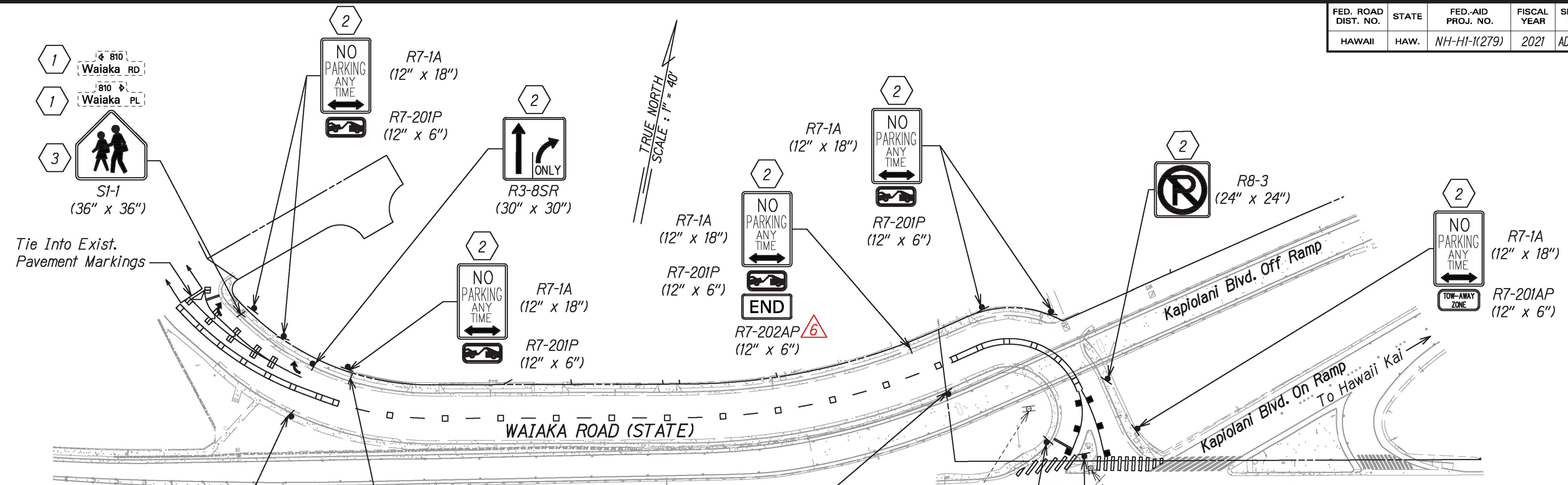

NOTE:
For pavement marking and signing legend, see Sht. M1

SIGNING KEY:

- 1 Exist. Sign(s) & Post(s) to Remain
- 2 Remove Exist. Sign(s) w/ Post(s) & Install New Sign(s) w/ Post(s)
Install Type II Reflector Marker (RM-2, Yellow) on New Post(s).
- 3 Remove Exist. Sign(s) & Install New Sign(s) on Exist. Post(s)

- NOTES:**
1. Bolt Down Curbing System color shall be White.
 2. Bolt Down Curbing System shall be Crashworthiness Tested to 2009 M.A.S.H. Standards.
 3. Install using 1/2" x 4" concrete screw anchors or 5/8" x 5" plastic sleeve anchors.

LONGITUDINAL CHANNELIZING CURB SYSTEM

NOT TO SCALE

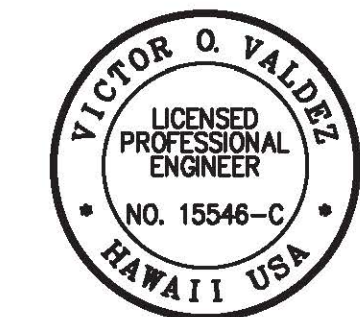

THIS WORK WAS PREPARED BY ME OR UNDER MY SUPERVISION

SIGNATURE: *[Signature]* 04/30/22
EXPIRATION DATE OF THE LICENSE

7/21/21	Updated Sign Description and Added Longitudinal Channelizing Curb System Details
DATE	REVISION
STATE OF HAWAII DEPARTMENT OF TRANSPORTATION HIGHWAYS DIVISION	
PAVEMENT MARKING & SIGNING PLAN	
INTERSTATE ROUTE H-1 RESURFACING Miller Pedestrian Overpass to Kapiolani Interchange Federal-Aid Project No. NH-H1-1(279)	
Scale: 1" = 40'	Date: August 2021
SHEET No. M24 OF 34 SHEETS	

C:_CIVIL_3D_PROJECTS\2016_2022\000_DOT-HWYS H1-RESURFACING - MILLER TO KAPITOLI CIVIL DRAWINGS\M19 - M24 - PAVEMENT MARKING AND SIGNING PLANS.DWG 7/28/2021 10:20 PM

FED. ROAD DIST. NO.	STATE	FED. AID PROJ. NO.	FISCAL YEAR	SHEET NO.	TOTAL SHEETS
HAWAII	HAW.	NH-H1-1(279)	2021	ADD. 166	304

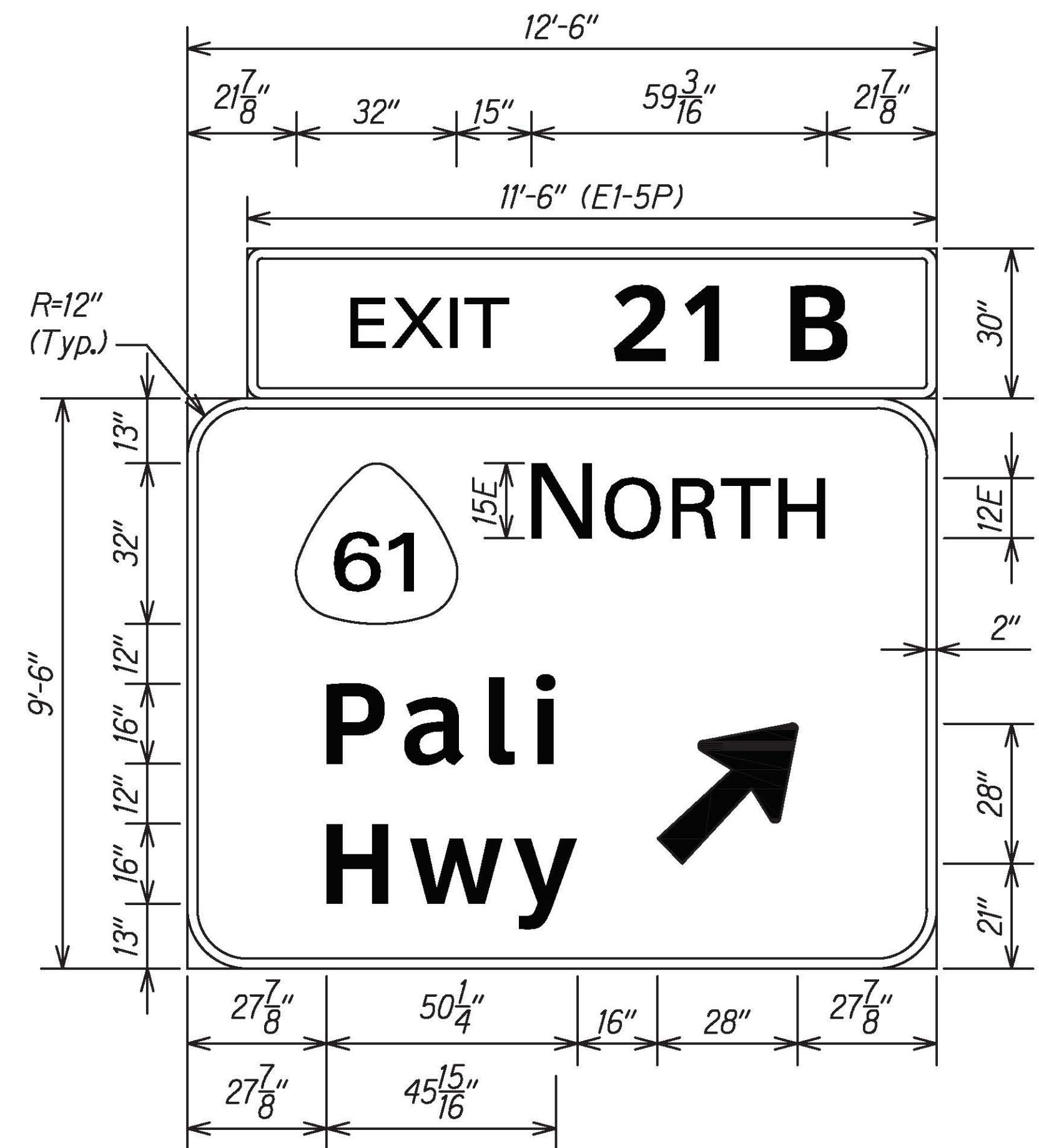

E-1 (White on Green)
Scale: 1/2" = 1'-0"

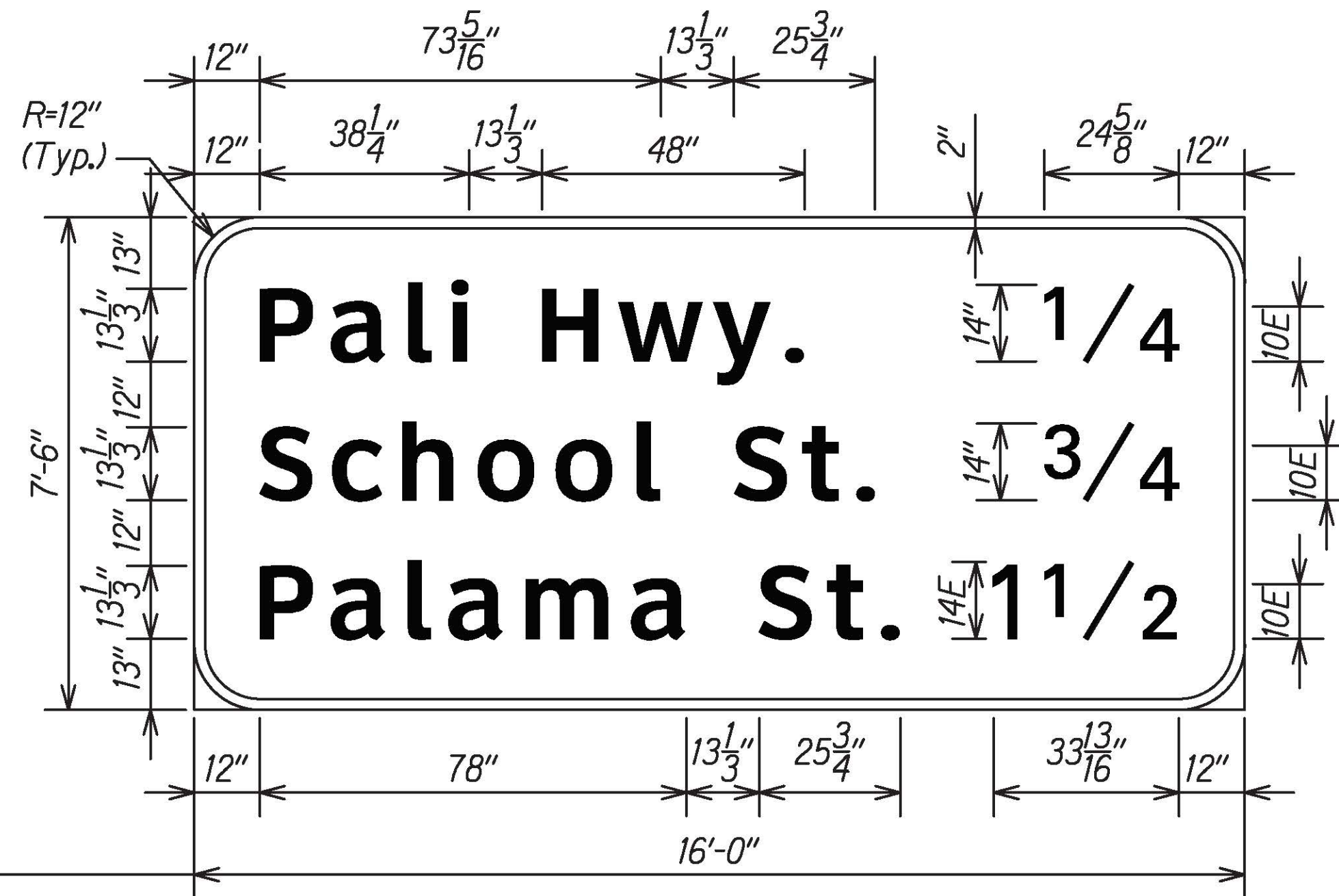

E-3 (White on Green)
Scale: 1/2" = 1'-0"

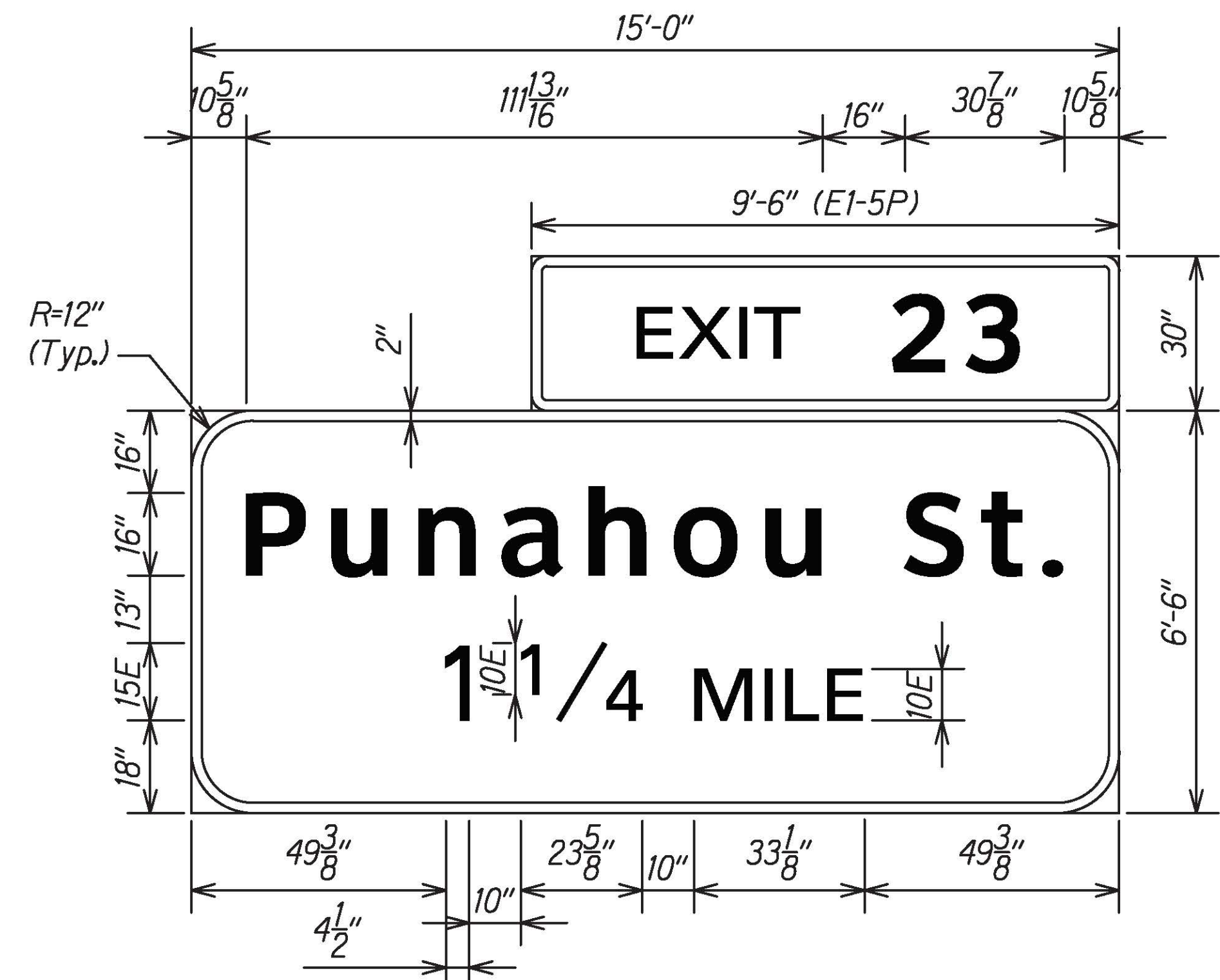

E-2 (L) (White on Green)
Scale: 1/2" = 1'-0"

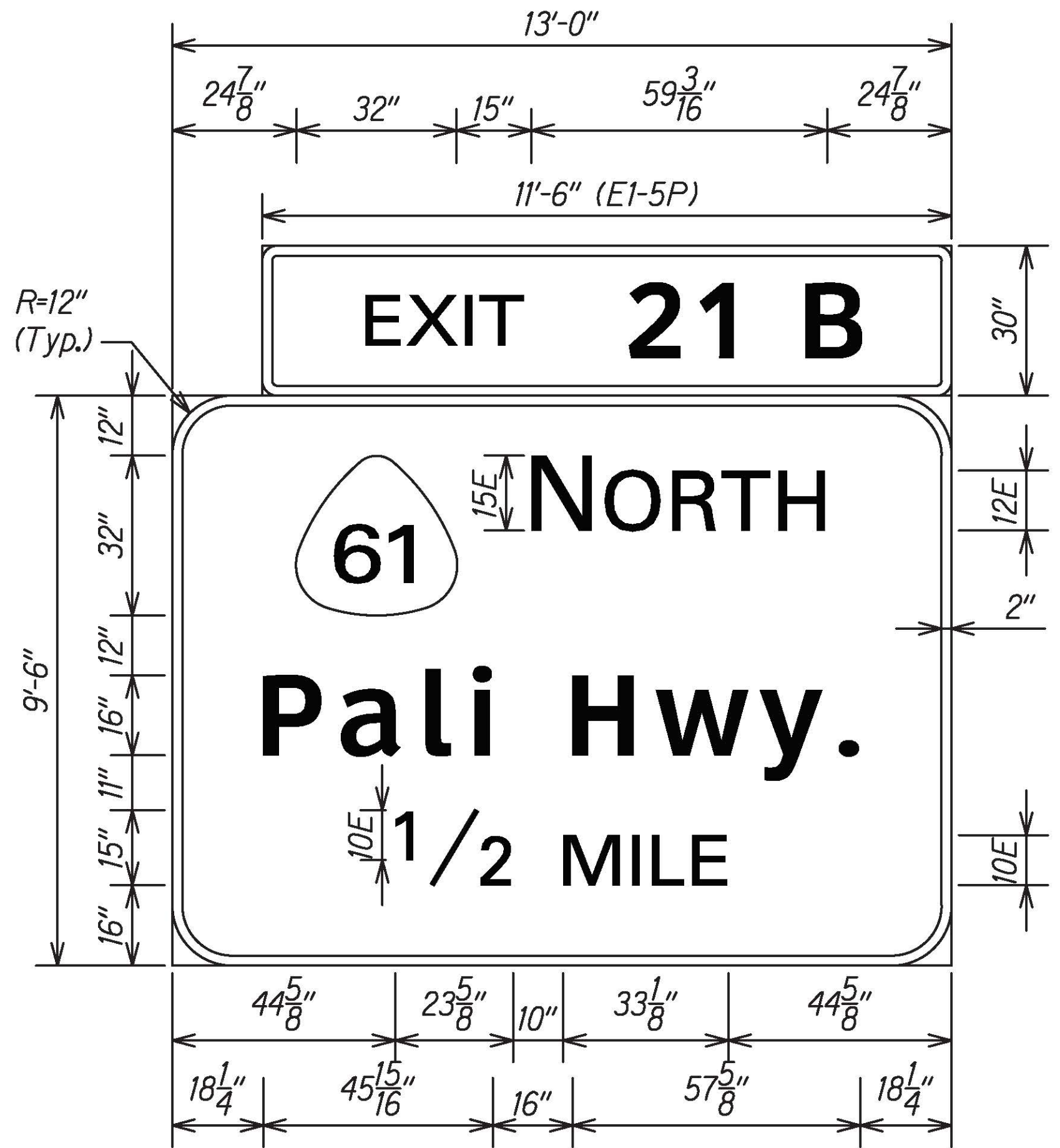

E-4 (C) (White on Green)
Scale: 1/2" = 1'-0"

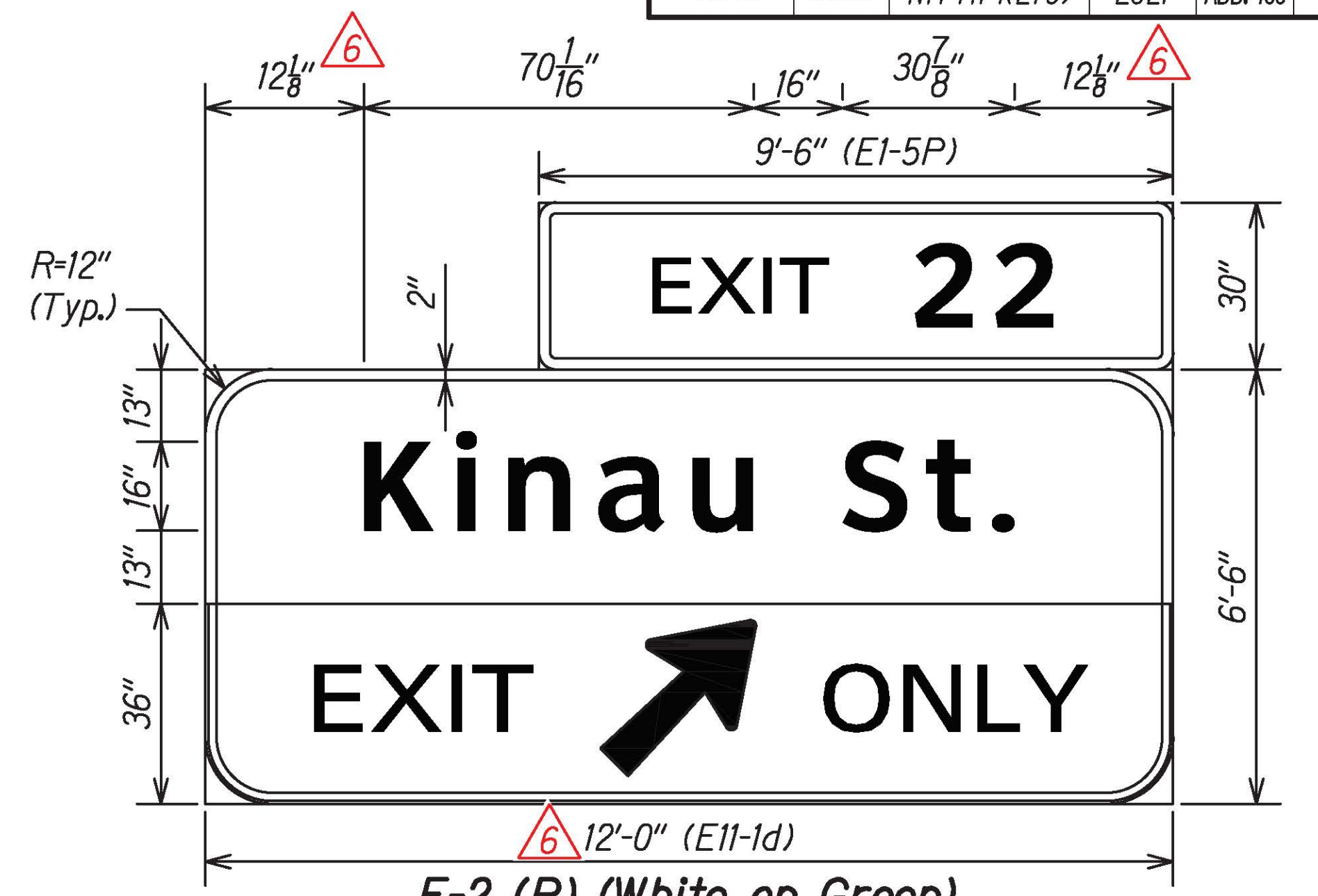

E-2 (R) (White on Green)
Scale: 1/2" = 1'-0"

NOTES:

- All signs conform to Section 630 - Traffic Control Guide Signs of the Standard Specifications and the latest editions amendments of the following FHWA publications:
 - "Manual on Uniform Traffic Control Devices for Streets and Highways" (MUTCD)
 - "Standard Highway Signs"
 - "Standard Alphabets for Highway Signs"
- Borders, messages, arrows symbols and shield conform to details as shown on the plans and as specified in the MUTCD.
- Sign messages shall be as indicated on the plans.
- All panels shall be retroreflectorized in accordance with subsection 750.01(A)(1) - Retroreflectorization of the Standard Specifications.
- Contractor shall submit all sign splicing details to the Engineer for acceptance.

EXPRESSWAY (E) AND DESTINATION (D) SIGN NOTES:

- The Contractor shall verify the locations and dimensions of existing Sign Panels and supports.
- New sign panels shall be laminated aluminum or extruded aluminum.
- Letter size:
 - When letters are all uppercase, use series "E".
 - When initial uppercase letter is used in conjunction with lowercase letters, use Clearview 5-W.
- Incidental parts and services not shown on the plans or specified but deemed necessary for the sign installation, shall be furnished and installed by the Contractor as part of the work contracted.
- Removal and disposal of existing sign panels, posts with foundation, luminaries and supports will not be paid for separately, but shall be considered incidental to the various signing items.

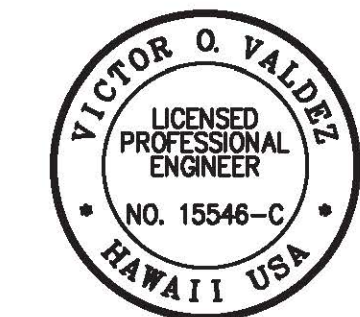

THIS WORK WAS PREPARED BY ME OR UNDER MY SUPERVISION
 SIGNATURE: [Signature] 04/30/22
 EXPIRATION DATE OF THE LICENSE

7/21/21	Revised Sign Size
DATE	REVISION
STATE OF HAWAII DEPARTMENT OF TRANSPORTATION HIGHWAYS DIVISION	
SIGNAGE DETAILS	
INTERSTATE ROUTE H-1 RESURFACING Miller Pedestrian Overpass to Kapiolani Interchange Federal-Aid Project No. NH-H1-1(279)	
Scale: 1/2" = 1'-0"	Date: August 2021
SHEET No. M25 OF 34 SHEETS	

C:_CIVIL_3D_PROJECTS\2016_2022\000_DOT-HWYS_H1_RESURFACING - MILLER TO KAPITOLI CIVIL DRAWINGS\M25 - M29_SIGNING_PANEL_DETAILS.DWG 7/22/2021 11:20 AM

FED. ROAD DIST. NO.	STATE	FED. AID PROJ. NO.	FISCAL YEAR	SHEET NO.	TOTAL SHEETS
HAWAII	HAW.	NH-H1-1(279)	2021	167	304

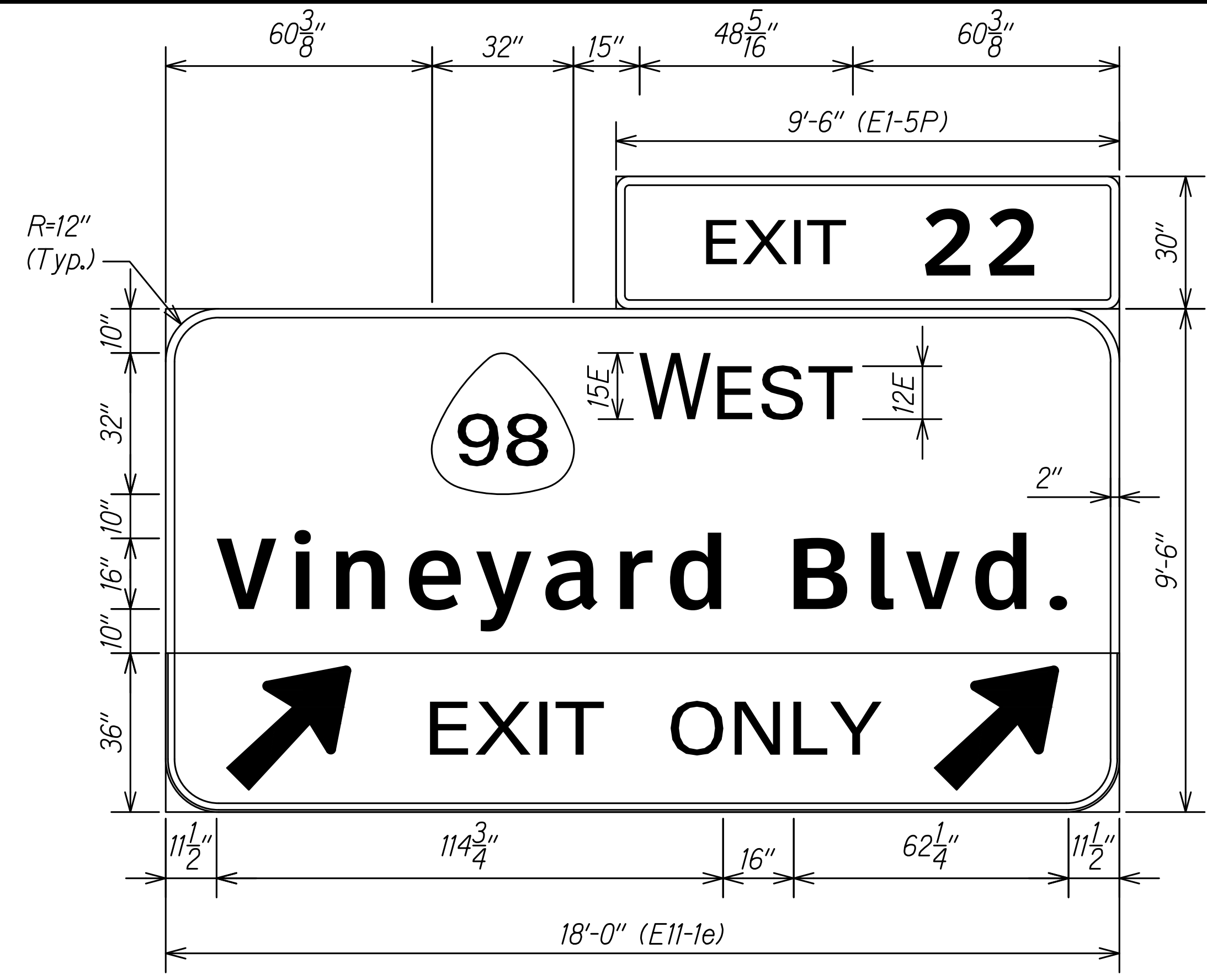

E-4 (R) (White on Green)
Scale: 1/2" = 1'-0"

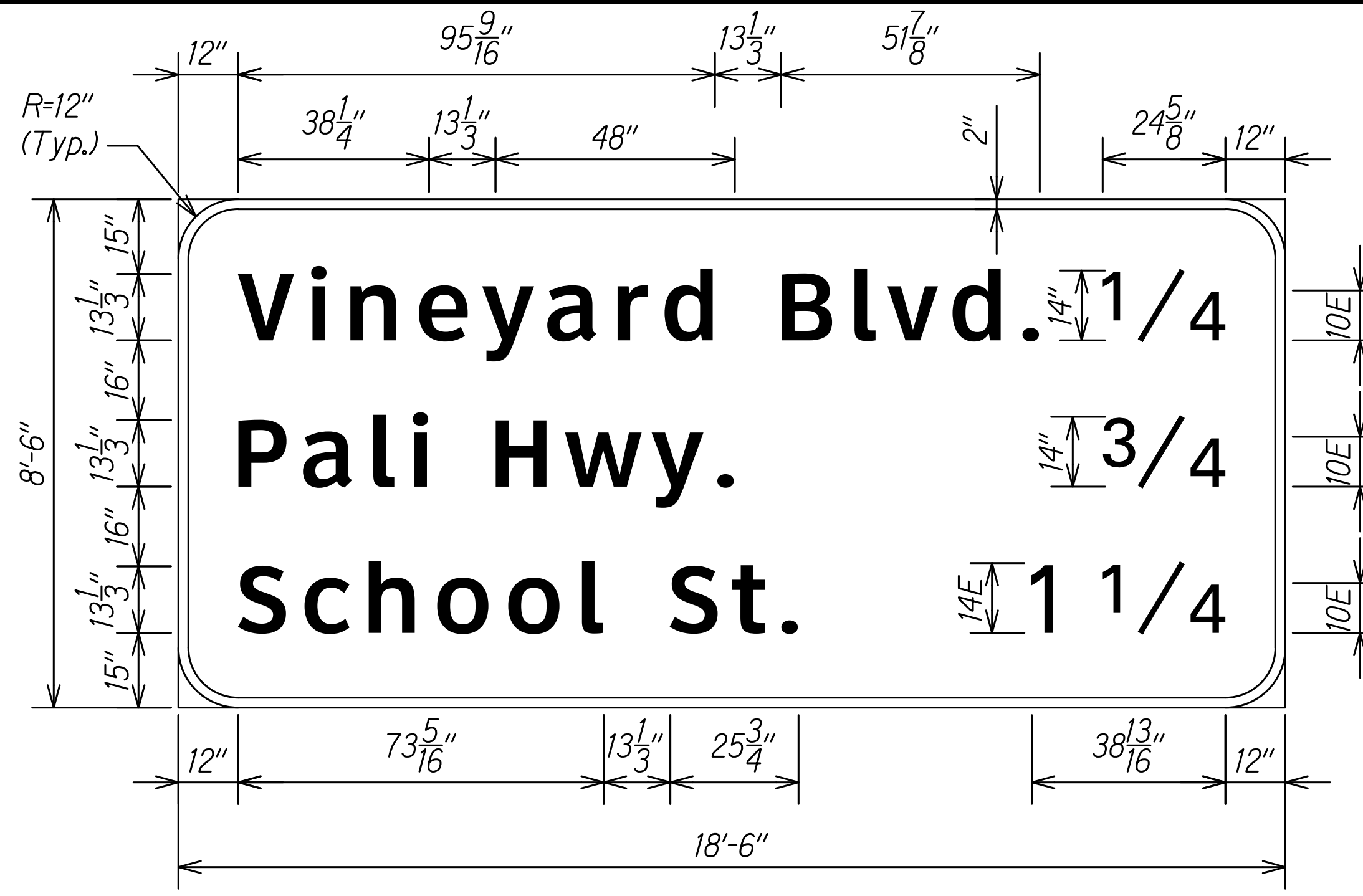

E-5 (White on Green)
Scale: 1/2" = 1'-0"

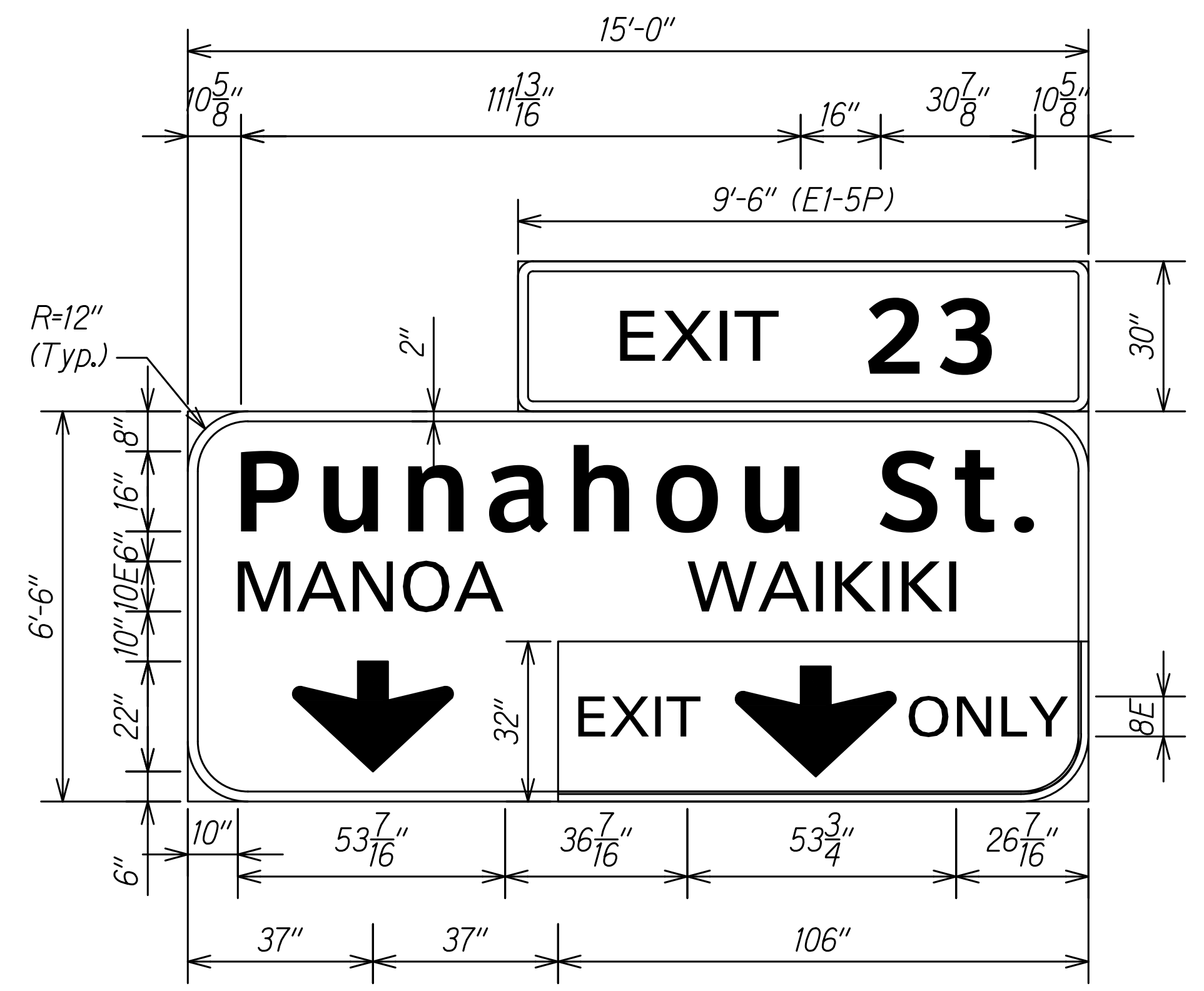

E-6 (White on Green)
Scale: 1/2" = 1'-0"

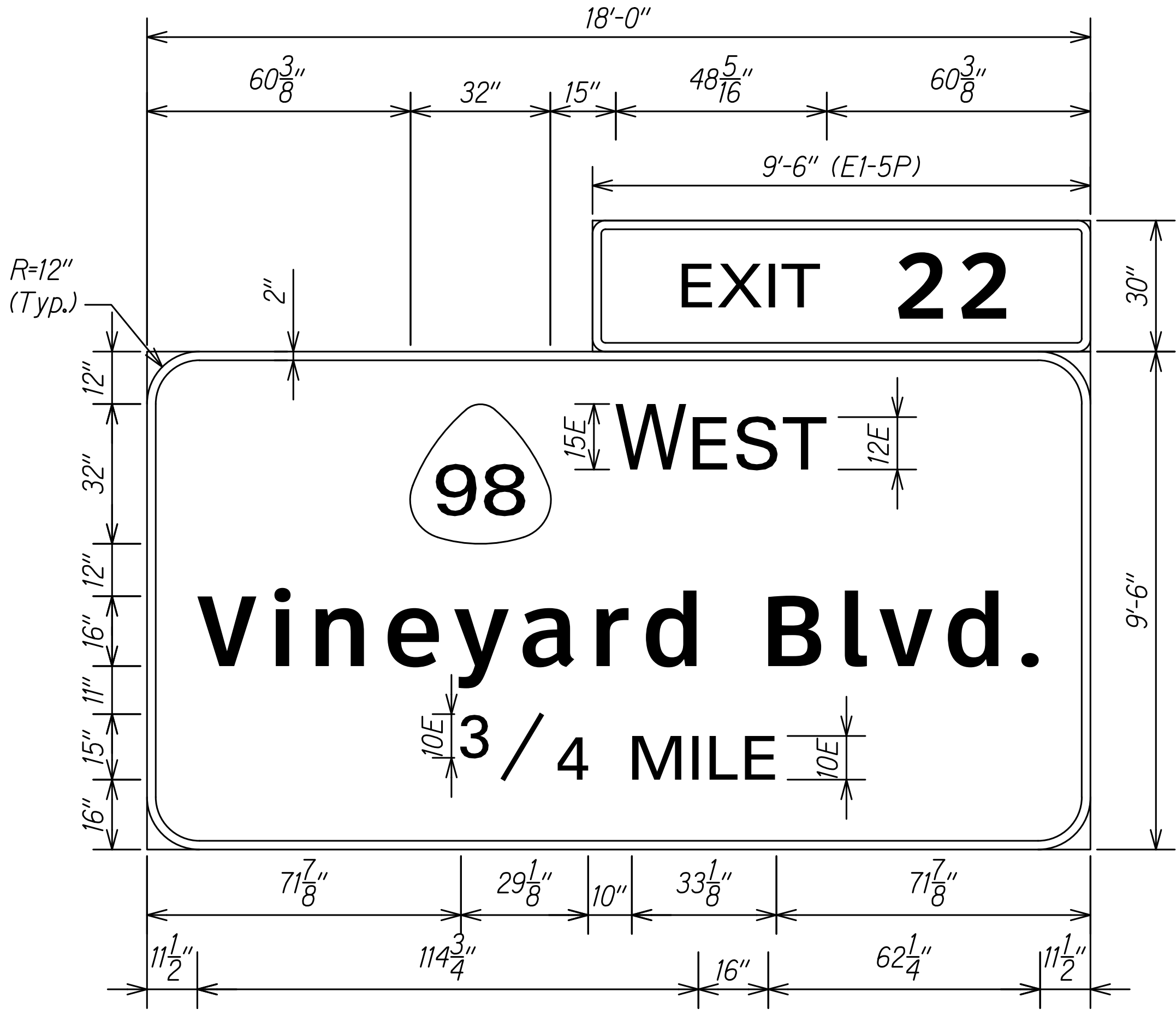

E-7 (L) (White on Green)
Scale: 1/2" = 1'-0"



E-7 (R) (White on Green)
Scale: 1/2" = 1'-0"

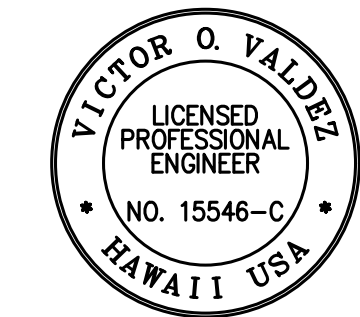

THIS WORK WAS PREPARED BY ME OR UNDER MY SUPERVISION
 SIGNATURE: *[Signature]* 04/30/22
 EXPIRATION DATE OF THE LICENSE

STATE OF HAWAII
 DEPARTMENT OF TRANSPORTATION
 HIGHWAYS DIVISION

SIGNAGE DETAILS

INTERSTATE ROUTE H-1 RESURFACING
 Miller Pedestrian Overpass to Kapiolani Interchange
 Federal-Aid Project No. NH-H1-1(279)

Scale: 1/2" = 1'-0" Date: August 2021

C:_CIVIL_3D_PROJECTS\2016_2022\000_DOT-HWYS_H1_RESURFACING - MILLER TO KAPITV01_CIVIL_DRAWINGS\M25 - M29_SIGNING_PANEL_DETAILS.DWG 9/1/2020 3:24 PM

FED. ROAD DIST. NO.	STATE	FED. AID PROJ. NO.	FISCAL YEAR	SHEET NO.	TOTAL SHEETS
HAWAII	HAW.	NH-H1-1(279)	2021	168	304

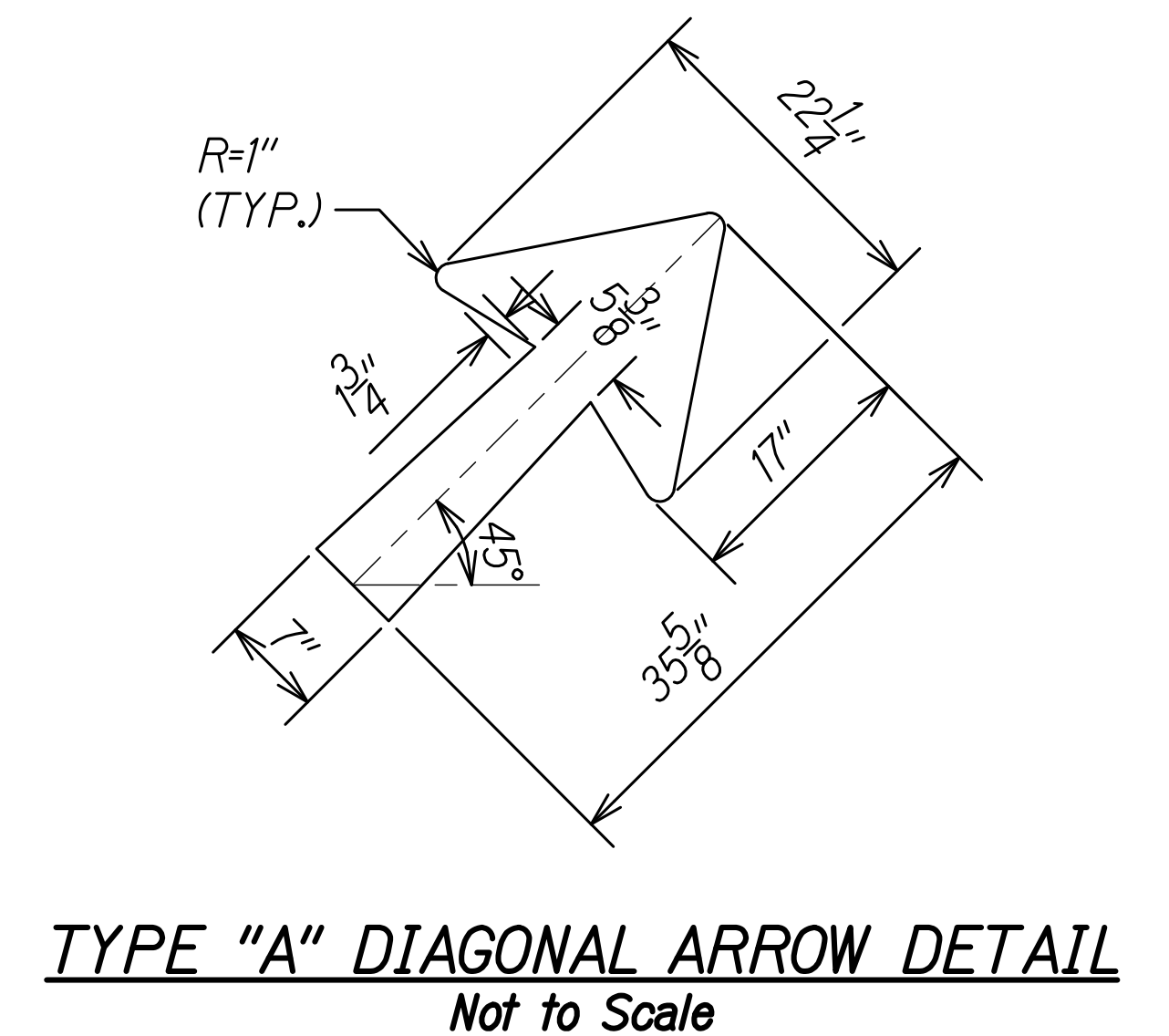
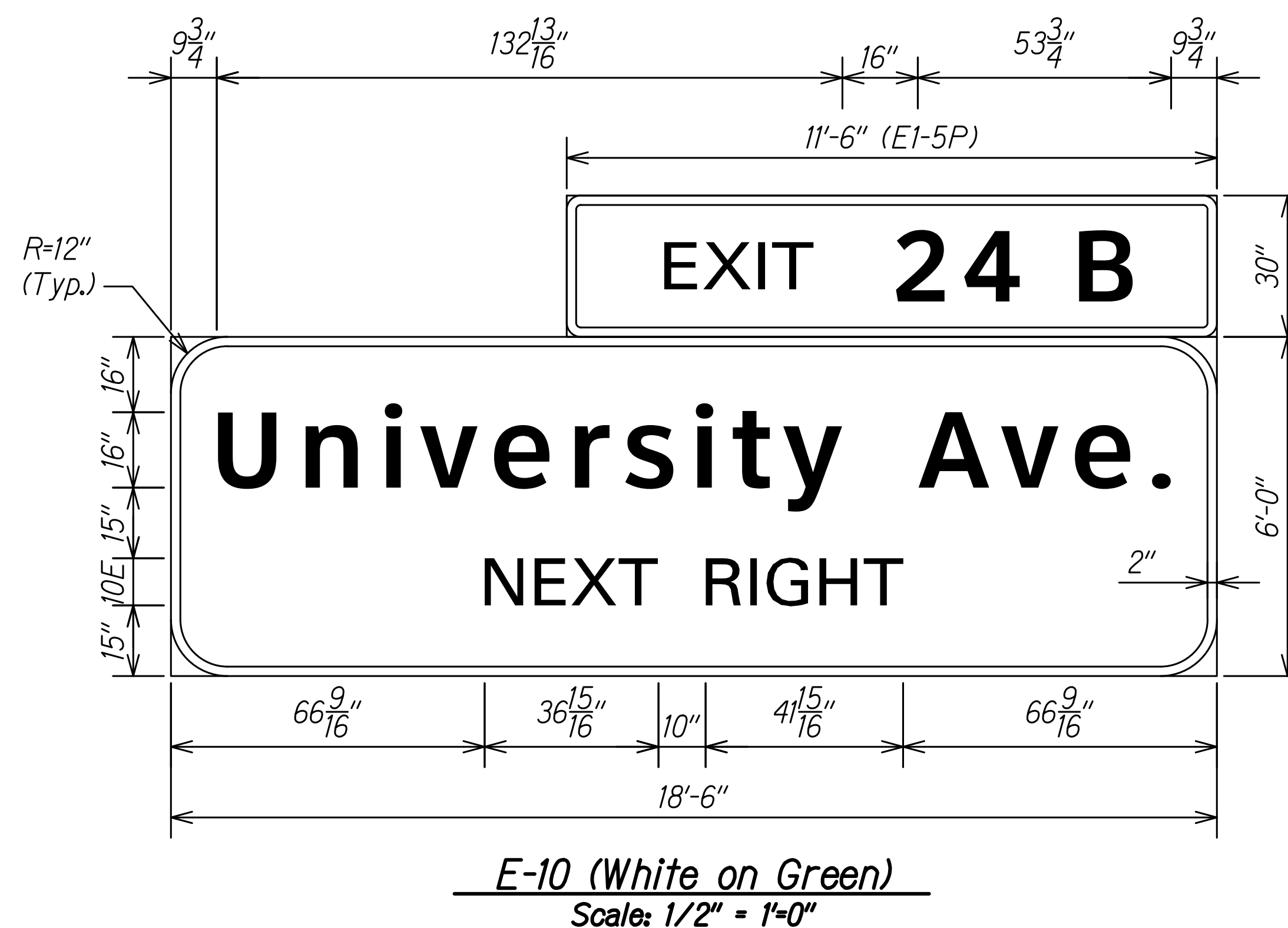
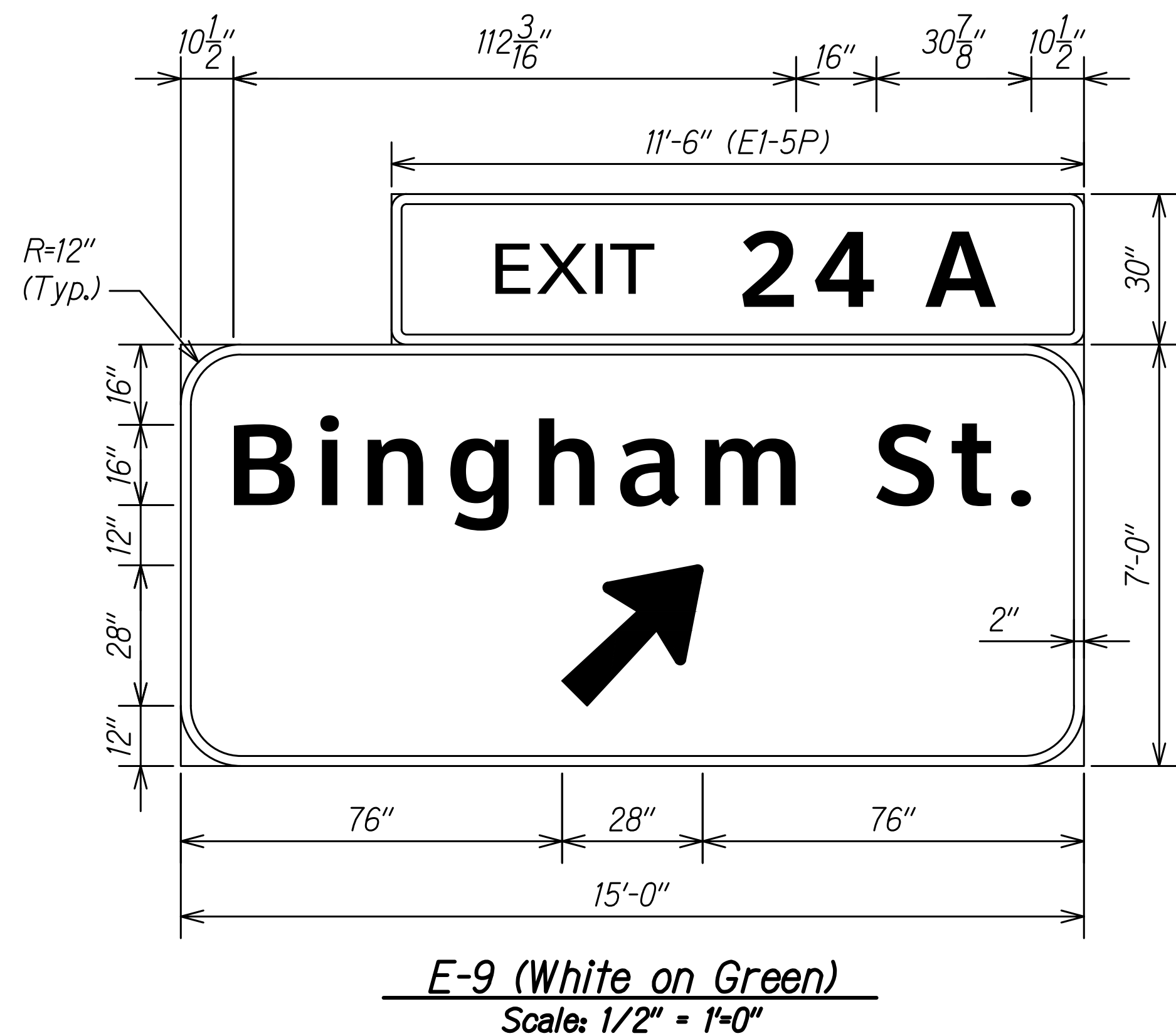
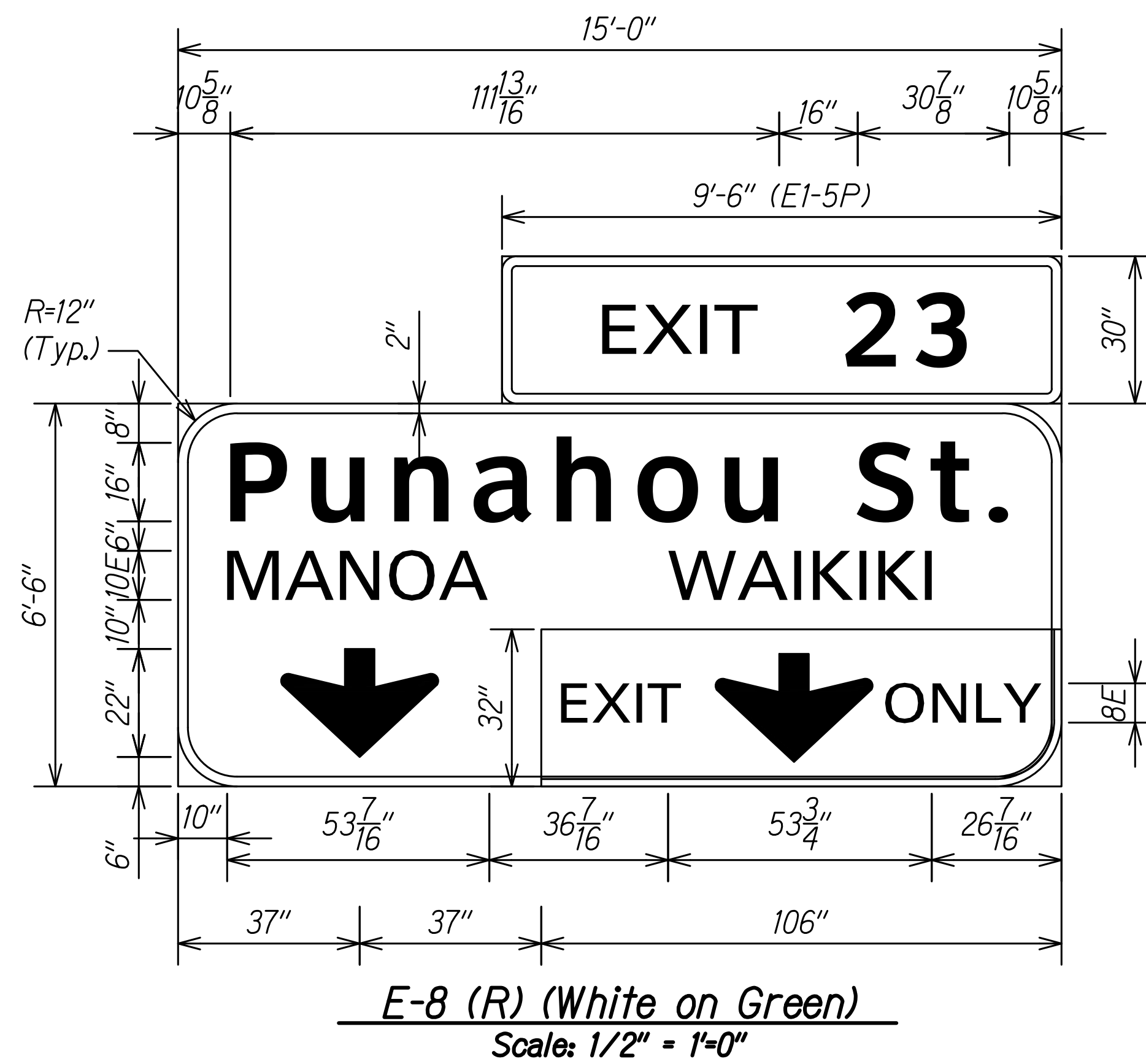
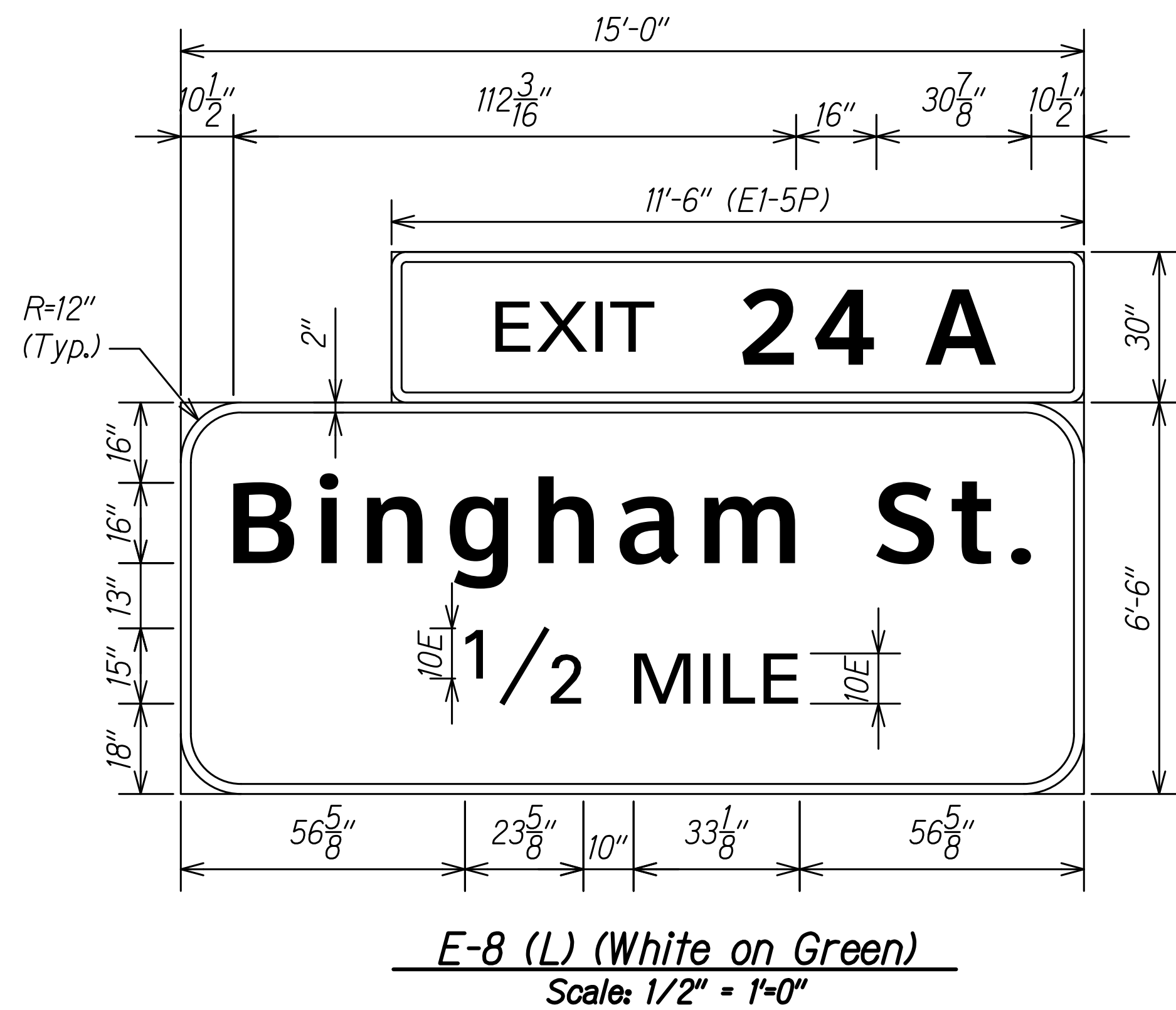

THIS WORK WAS PREPARED BY ME
OR UNDER MY SUPERVISION

SIGNATURE: *[Signature]* 04/30/22
EXPIRATION DATE OF THE LICENSE

STATE OF HAWAII
DEPARTMENT OF TRANSPORTATION
HIGHWAYS DIVISION

SIGNAGE DETAILS

INTERSTATE ROUTE H-1 RESURFACING
Miller Pedestrian Overpass to Kapiolani Interchange
Federal-Aid Project No. NH-H1-1(279)

Scale: 1/2" = 1'-0" Date: August 2021

C:_CIVIL_3D_PROJECTS\2016_2022\000_DOT-HWYS_H1_RESURFACING - MILLER TO KAPITV01_CIVIL_DRAWINGS\M25 - M29_SIGNING_PANEL_DETAILS.DWG 9/1/2020 3:24 PM

FED. ROAD DIST. NO.	STATE	FED. AID PROJ. NO.	FISCAL YEAR	SHEET NO.	TOTAL SHEETS
HAWAII	HAW.	NH-H1-1(279)	2021	169	304

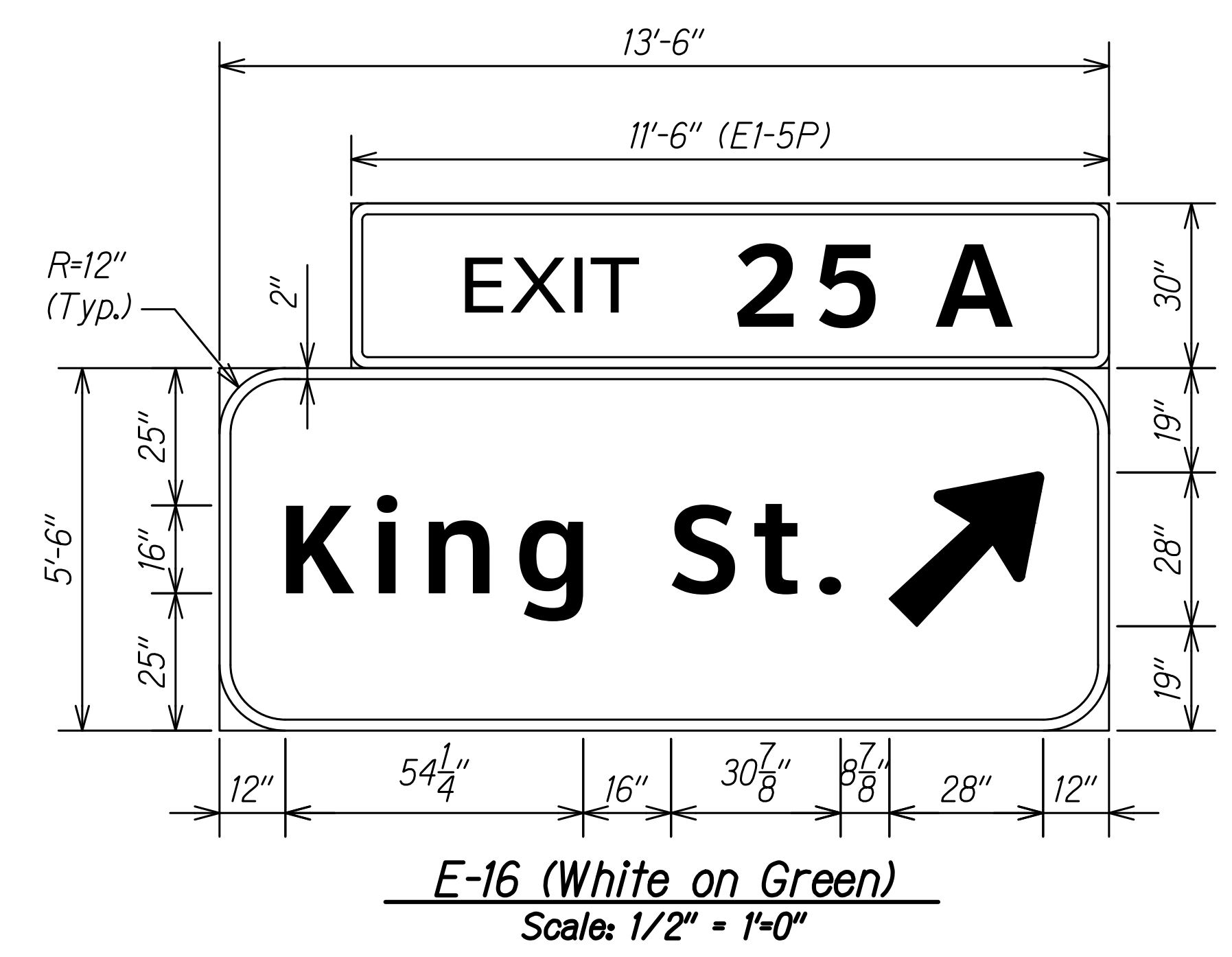
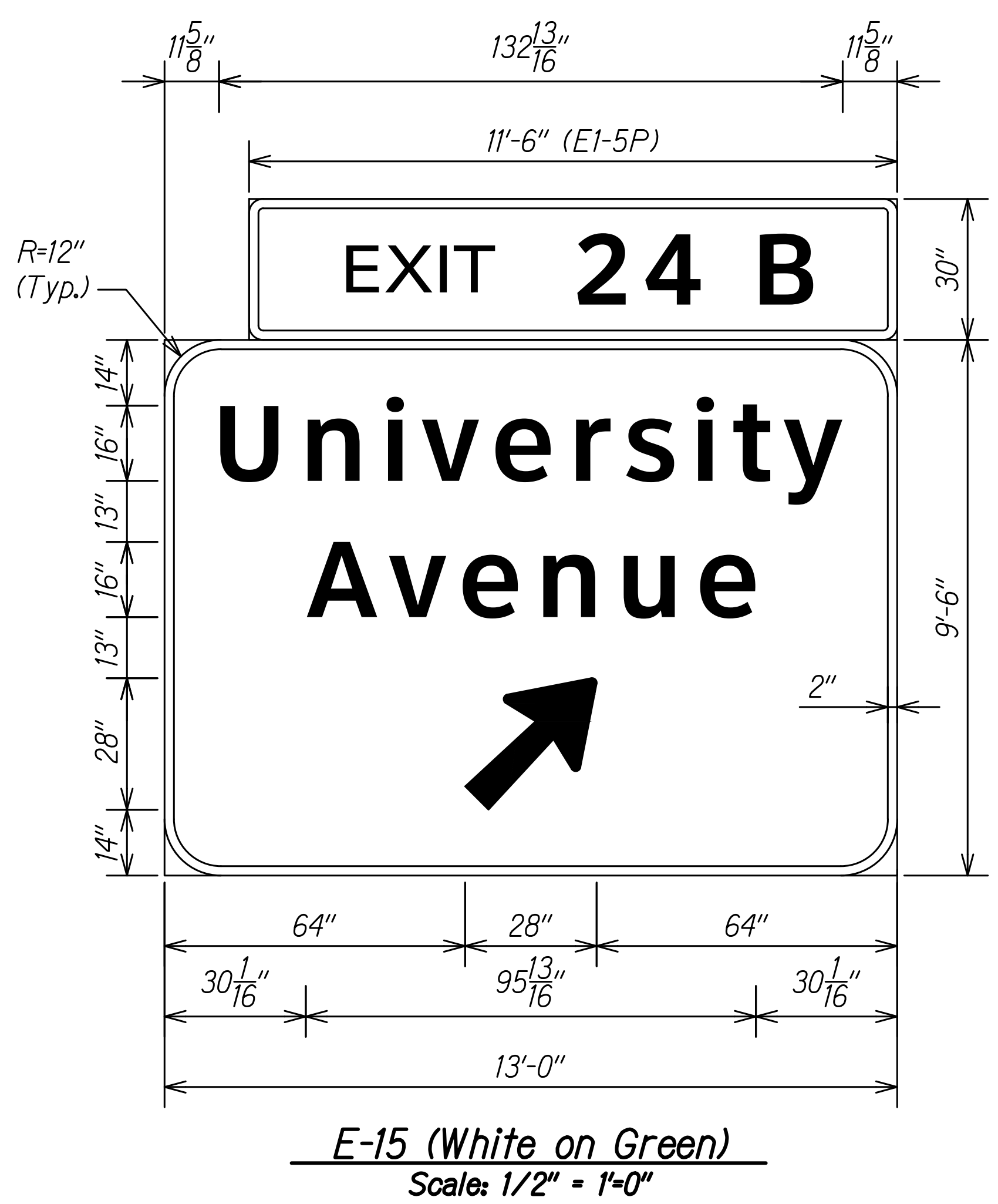
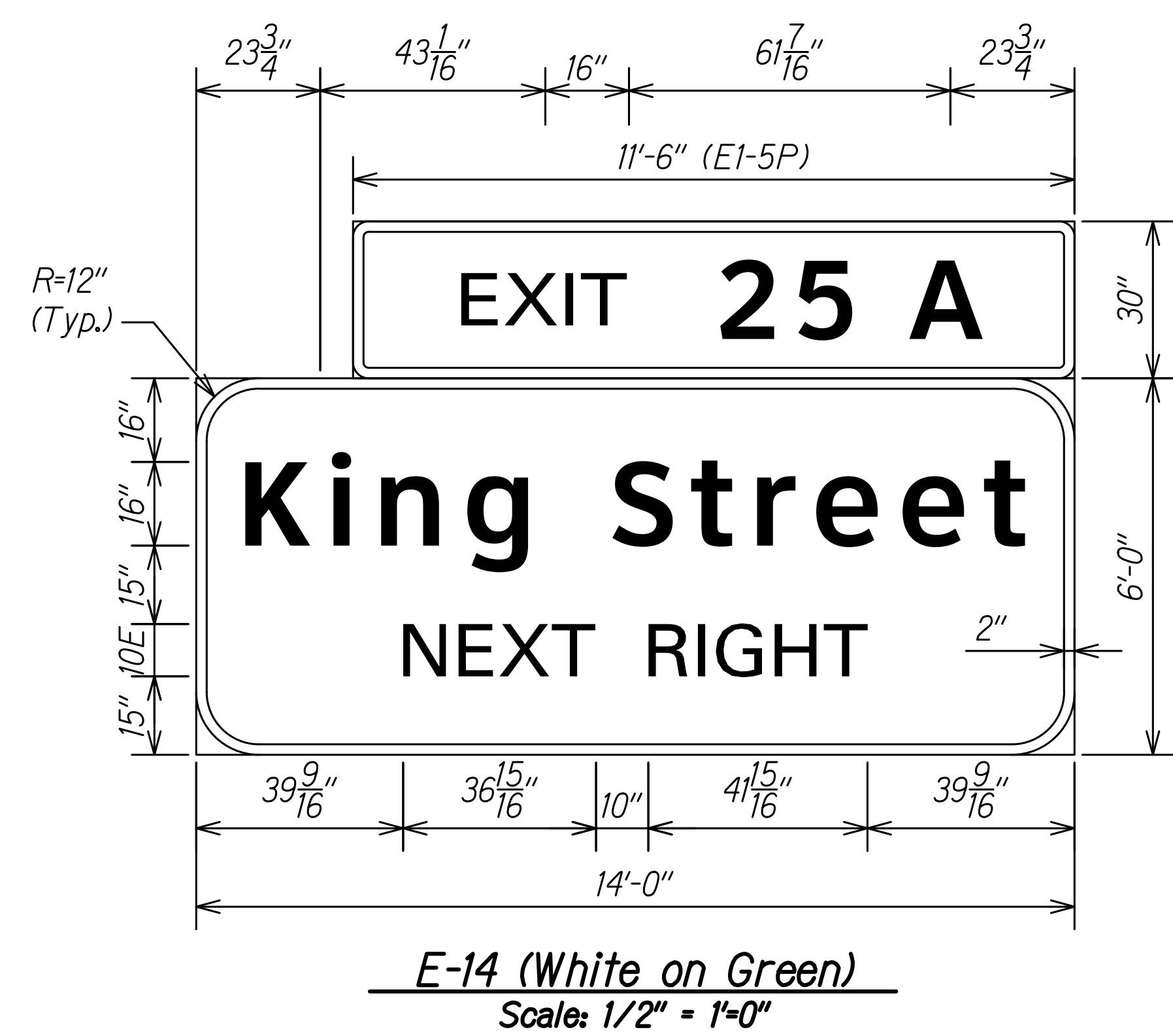
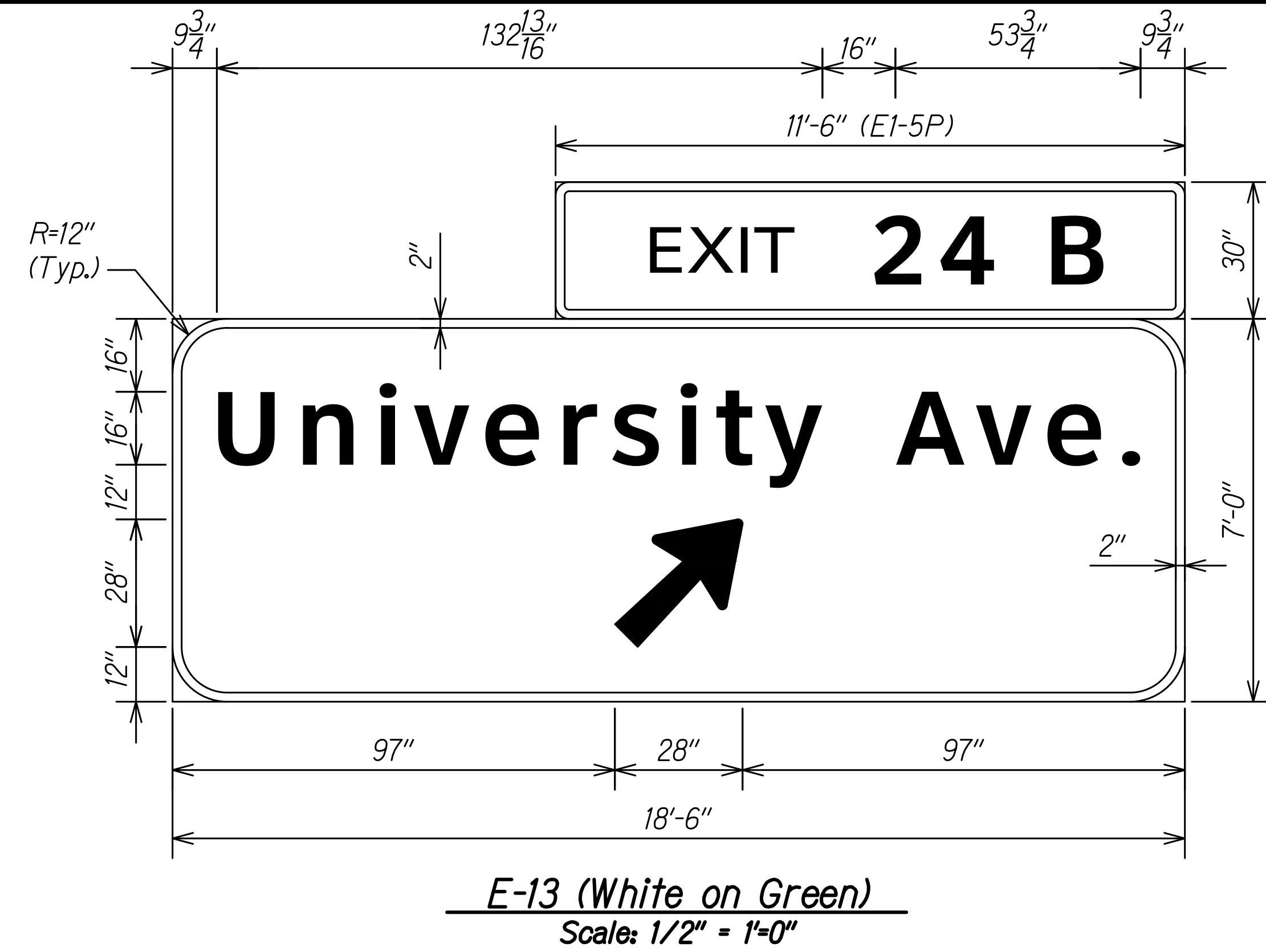
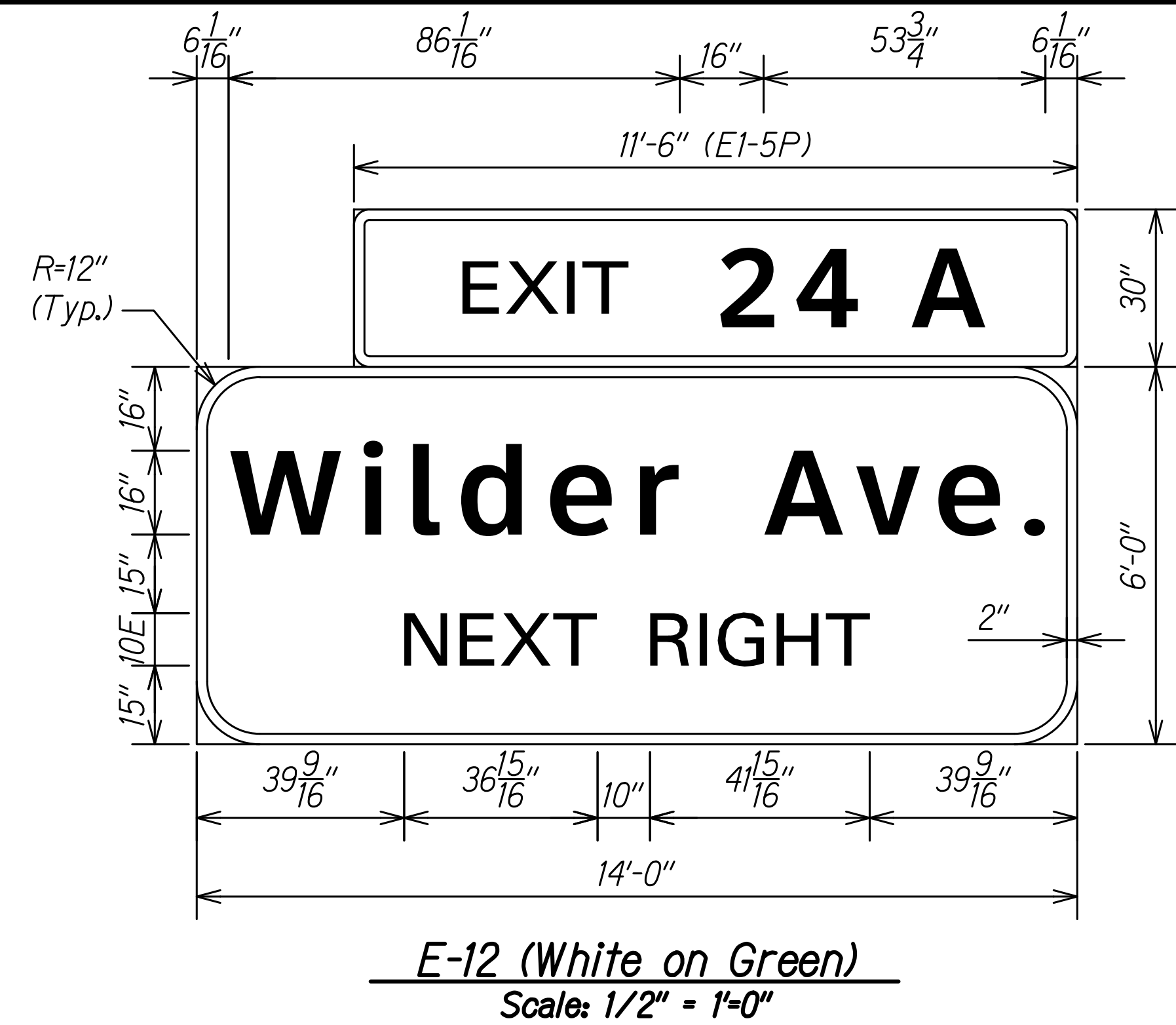

C:_CIVIL_3D_PROJECTS\2016_2022\000_DOT-HWYS_H1_RESURFACING - MILLER TO KAPITANI CIVIL DRAWINGS\M25 - M29_SIGNING_PANEL_DETAILS.DWG 9/1/2020 3:24 PM

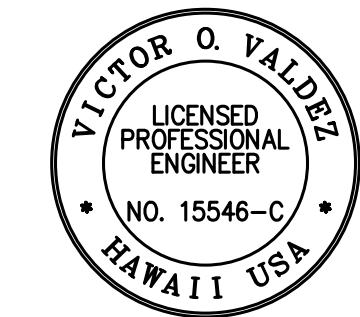

THIS WORK WAS PREPARED BY ME
OR UNDER MY SUPERVISION

[Signature] 04/30/22
SIGNATURE EXPIRATION DATE OF THE LICENSE

STATE OF HAWAII
DEPARTMENT OF TRANSPORTATION
HIGHWAYS DIVISION

SIGNAGE DETAILS

INTERSTATE ROUTE H-1 RESURFACING
Miller Pedestrian Overpass to Kapiolani Interchange
Federal-Aid Project No. NH-H1-1(279)

Scale: 1/2" = 1'-0" Date: August 2021

SHEET No. **M28** OF **34** SHEETS

FED. ROAD DIST. NO.	STATE	FED-AID PROJ. NO.	FISCAL YEAR	SHEET NO.	TOTAL SHEETS
HAWAII	HAW.	NH-H1-1(279)	2021	170	304

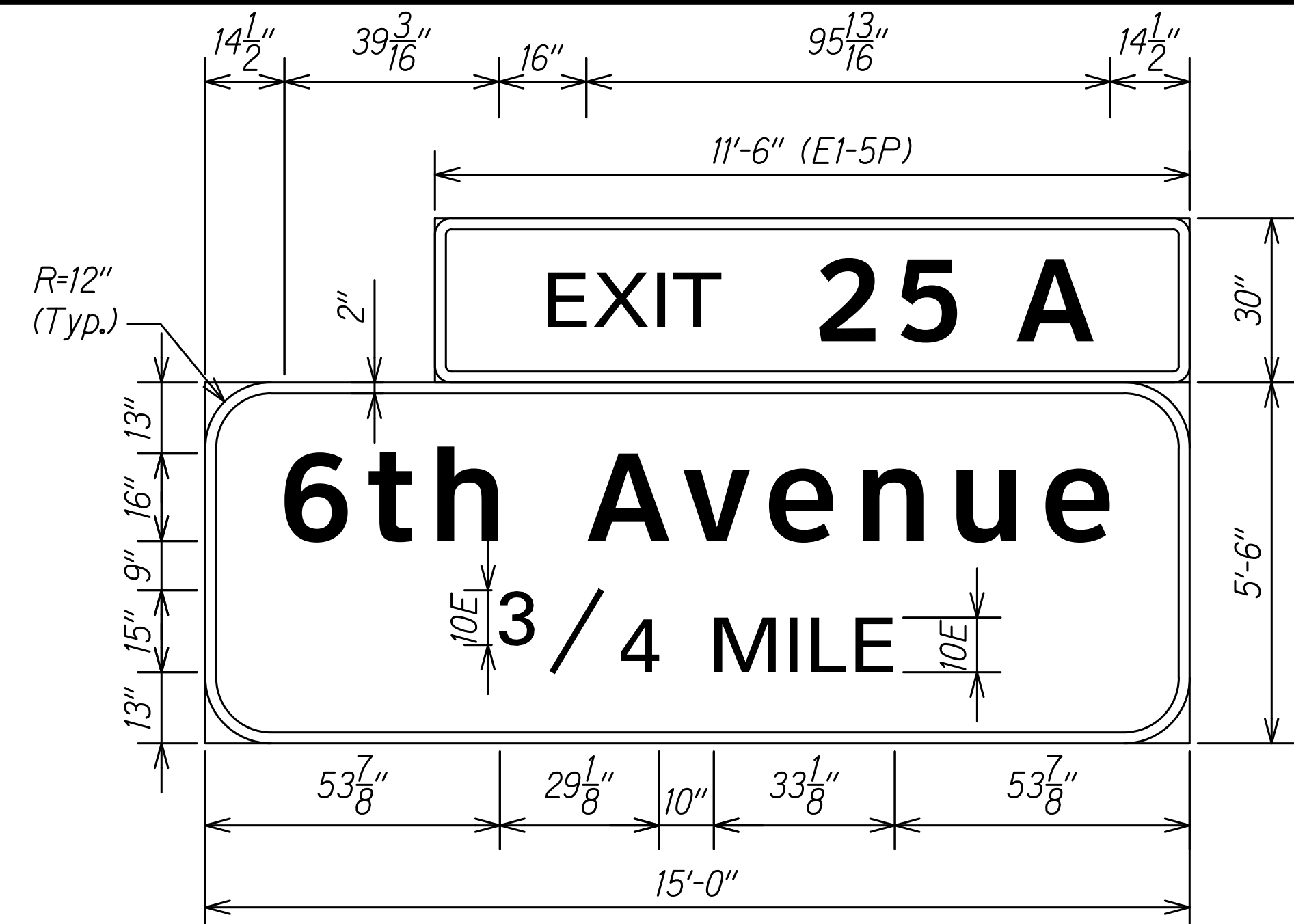

E-17 (White on Green)
Scale: 1/2" = 1'-0"



E-18 (White on Green)
Scale: 1/2" = 1'-0"

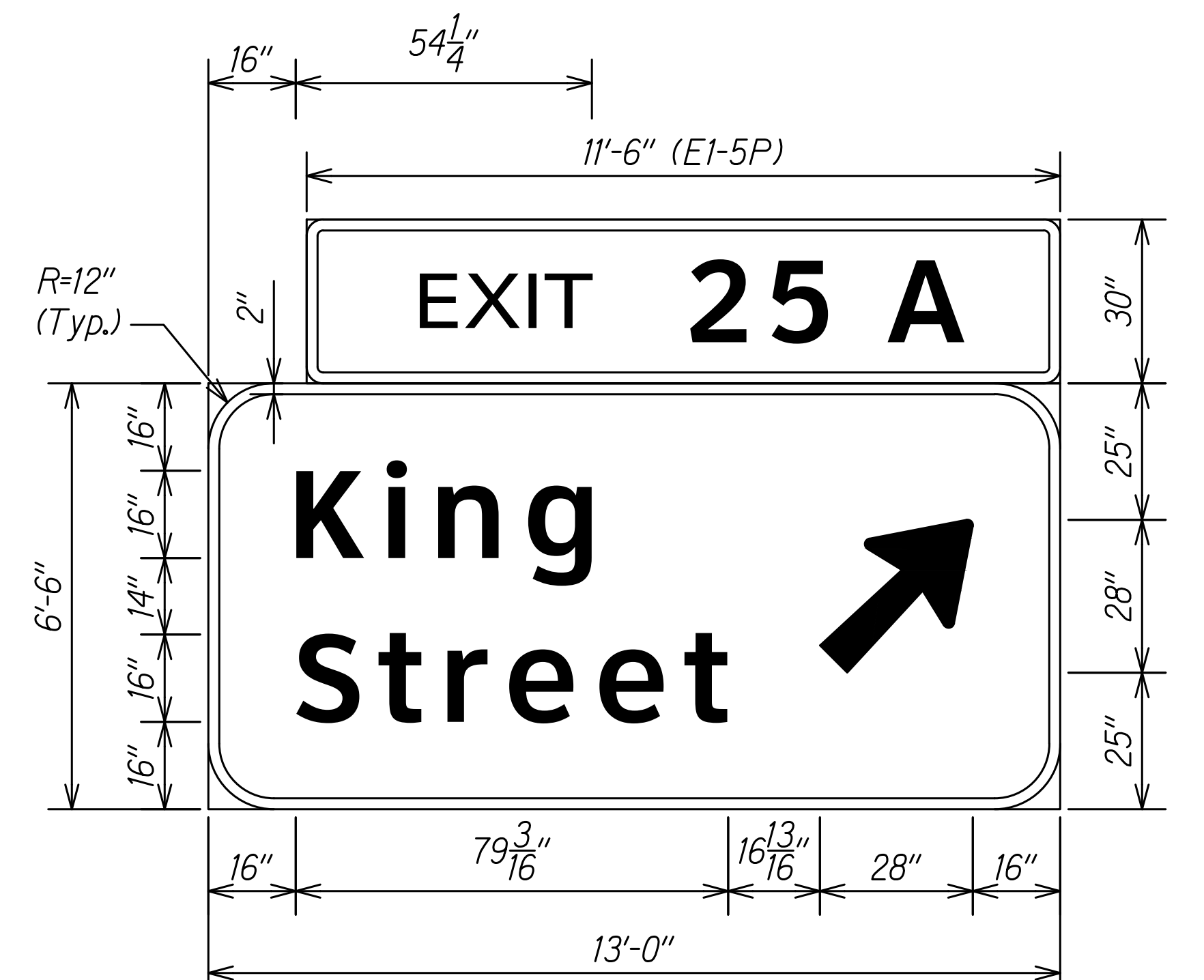

E-19 (White on Green)
Scale: 1/2" = 1'-0"

C:_CIVIL_3D_PROJECTS\2016_2022\000_DOT-HWYS_H1_RESURFACING - MILLER TO KAPINTY01 CIVIL DRAWINGS\M25 - M29_SIGNING_PANEL_DETAILS.DWG 9/1/2020 3:24 PM

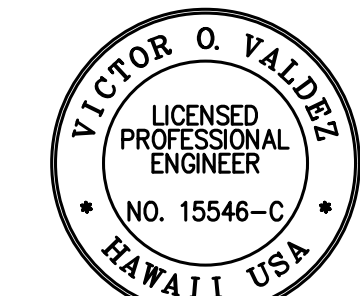

THIS WORK WAS PREPARED BY ME
OR UNDER MY SUPERVISION

[Signature]
SIGNATURE 04/30/22
EXPIRATION DATE
OF THE LICENSE

STATE OF HAWAII
DEPARTMENT OF TRANSPORTATION
HIGHWAYS DIVISION

SIGNAGE DETAILS

INTERSTATE ROUTE H-1 RESURFACING
Miller Pedestrian Overpass to Kapiolani Interchange
Federal-Aid Project No. NH-H1-1(279)

Scale: 1/2" = 1'-0" Date: August 2021

FED. ROAD DIST. NO.	STATE	FED. AID PROJ. NO.	FISCAL YEAR	SHEET NO.	TOTAL SHEETS
HAWAII	HAW.	NH-H1-1(279)	2021	171	304

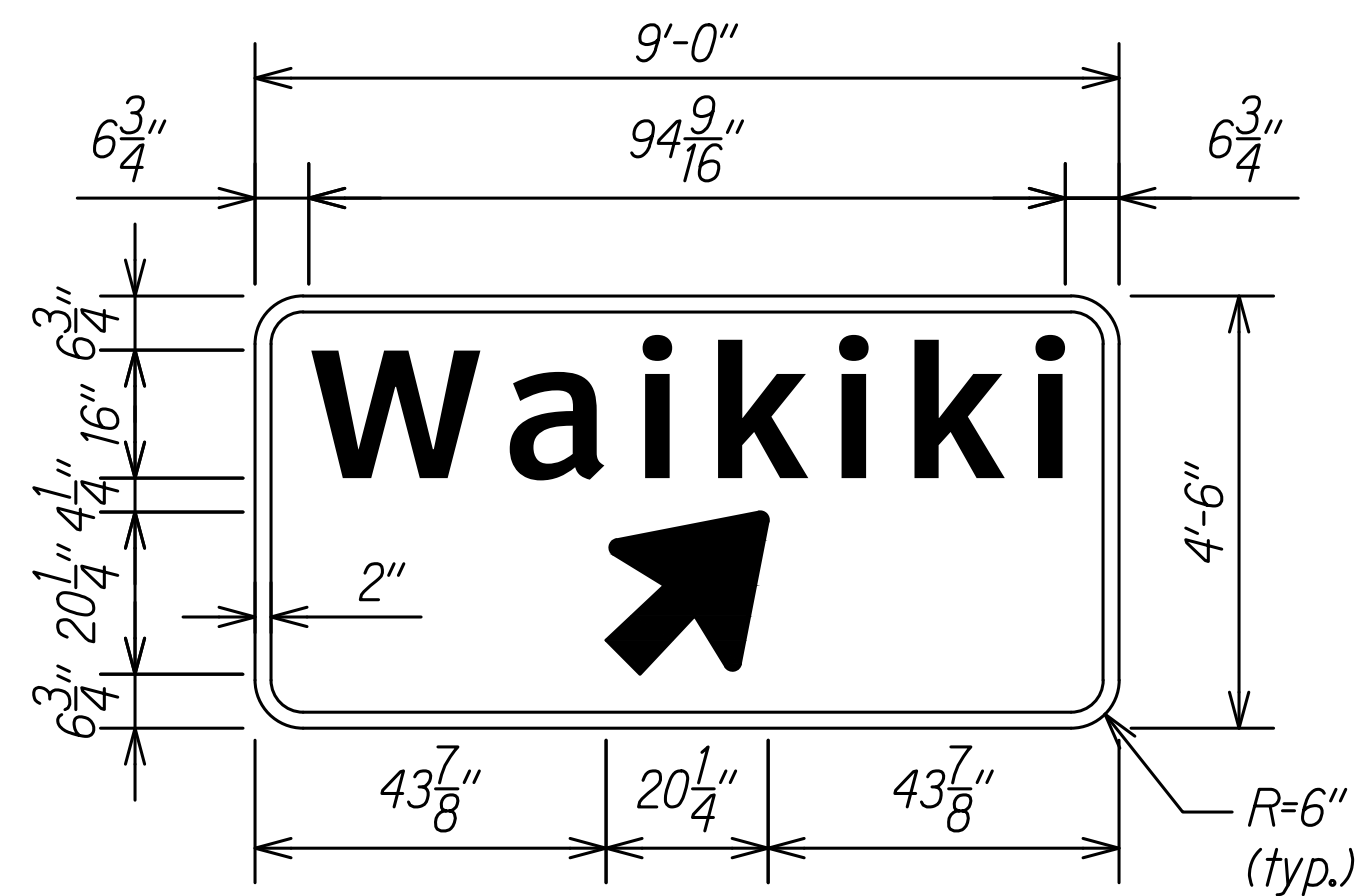

D-1
Not To Scale

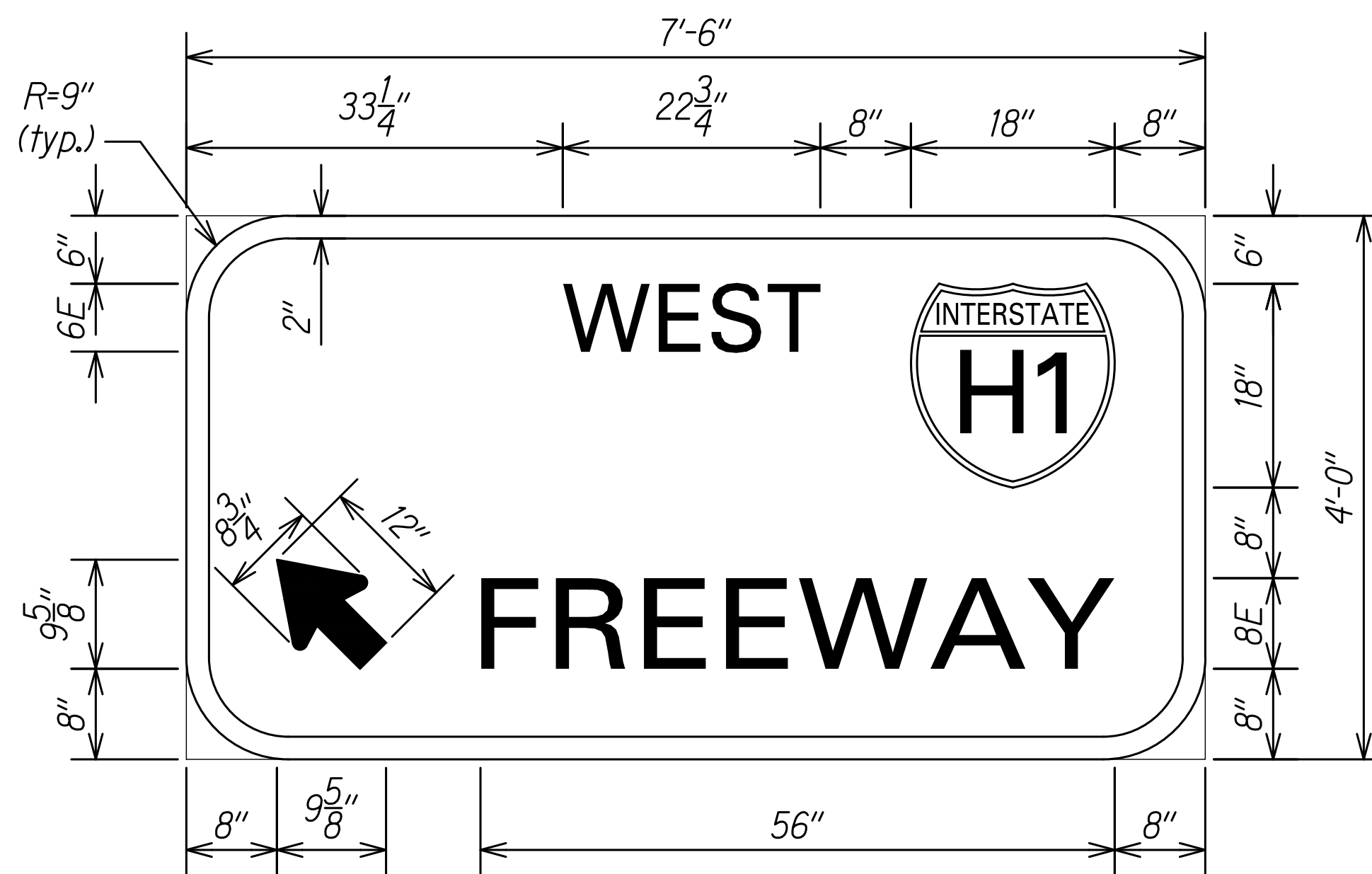

D-2
Not To Scale

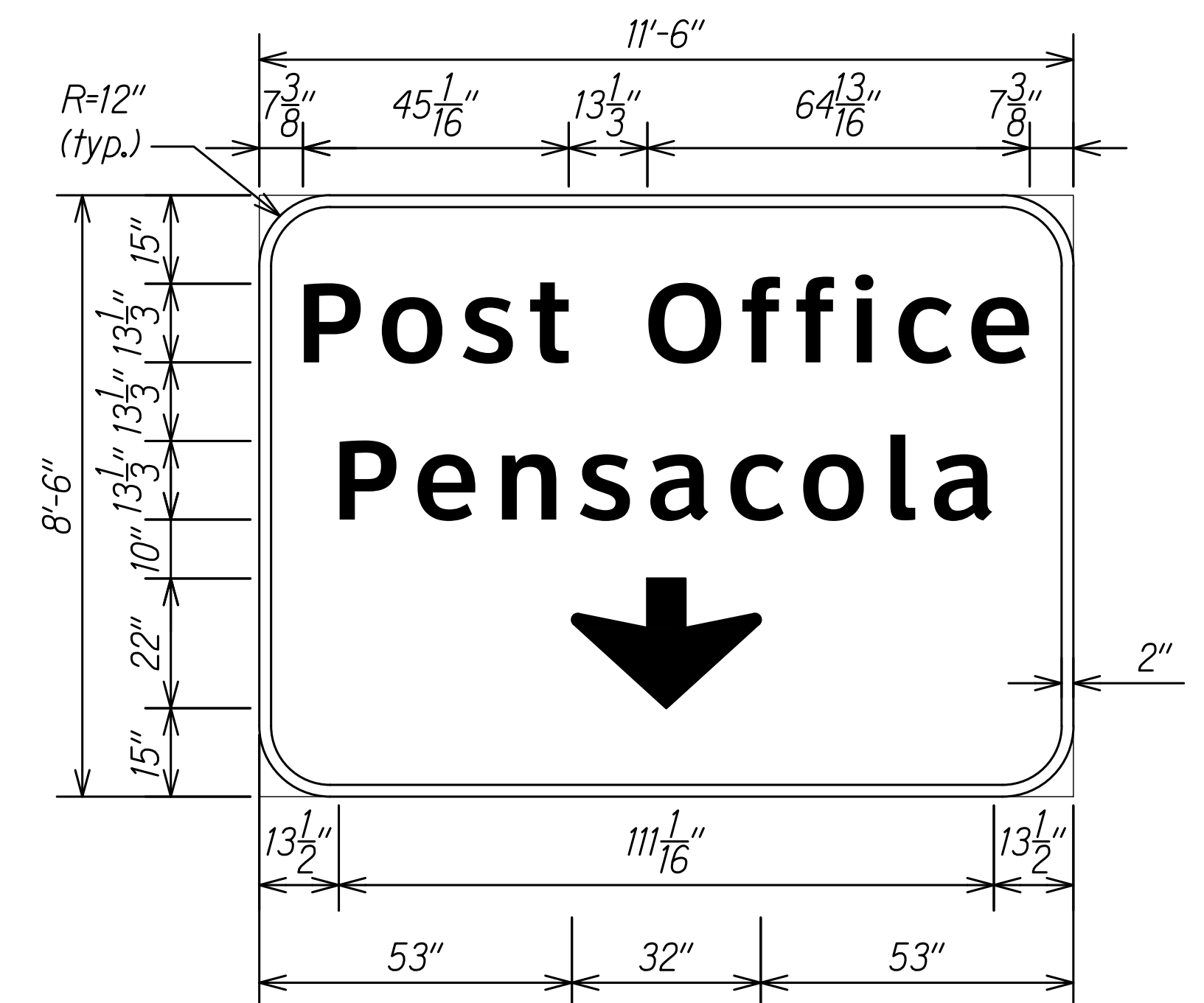

D-3 (L)
Not To Scale

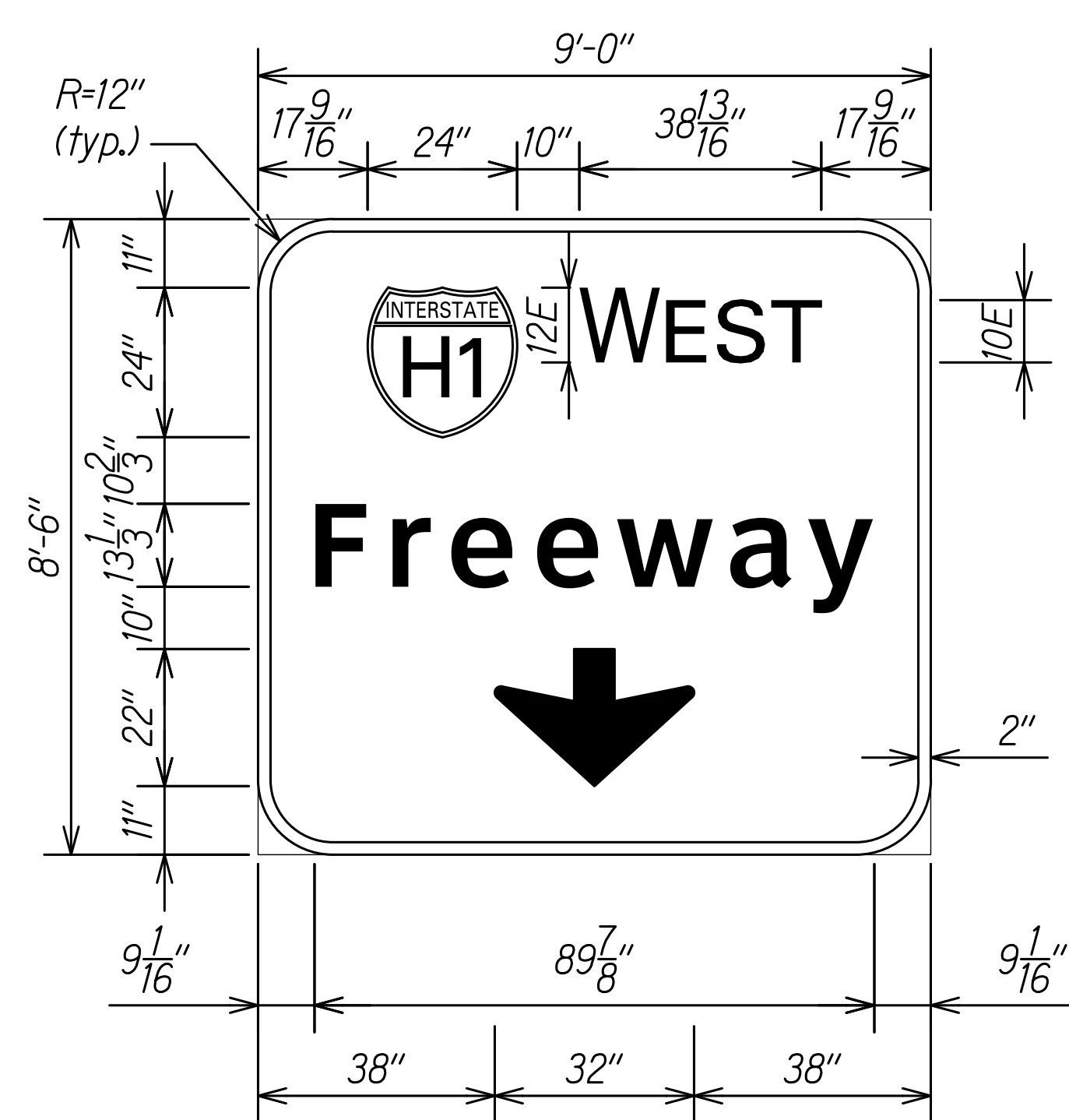

D-3 (R)
Not To Scale

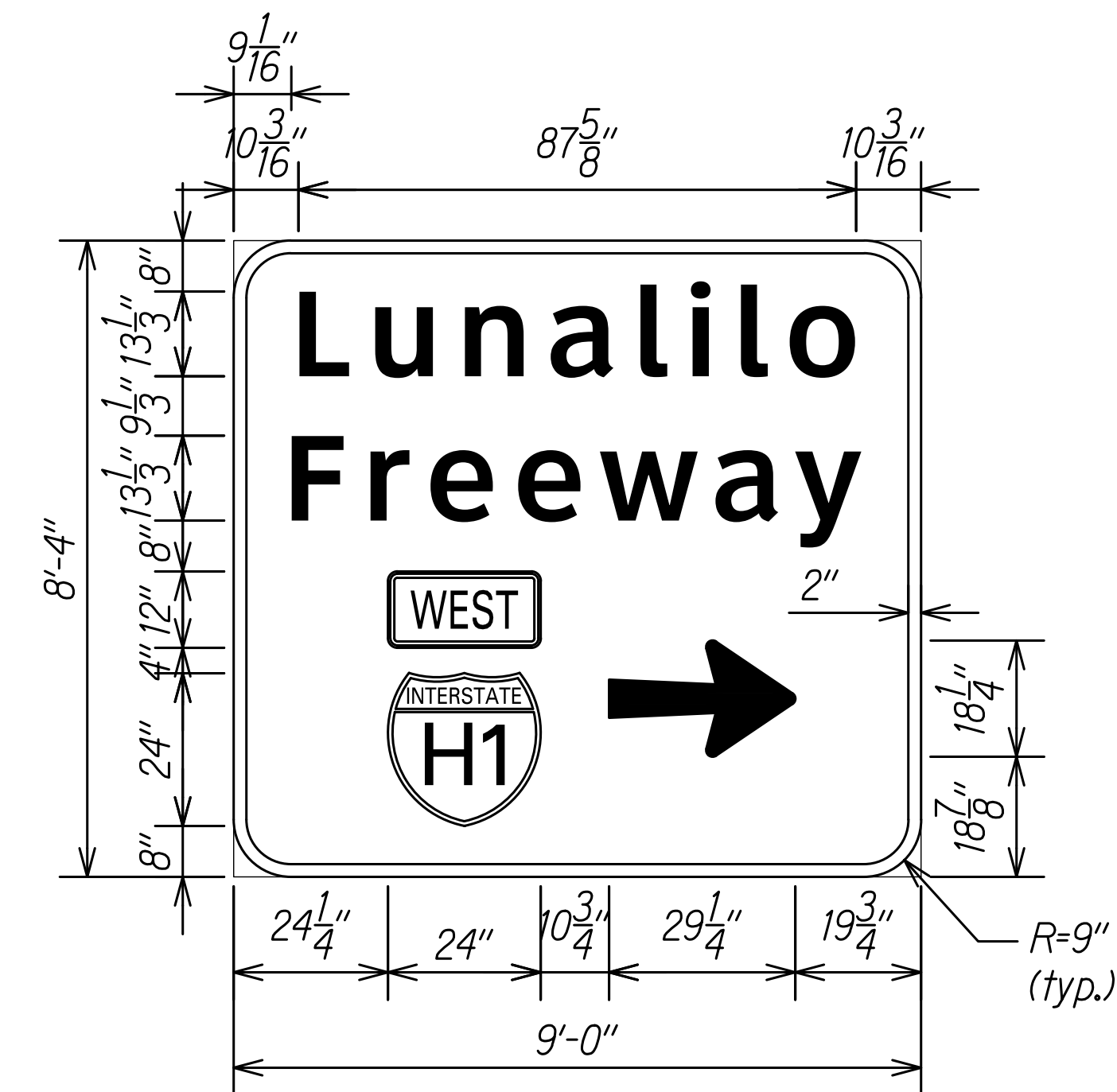

D-4
Not To Scale

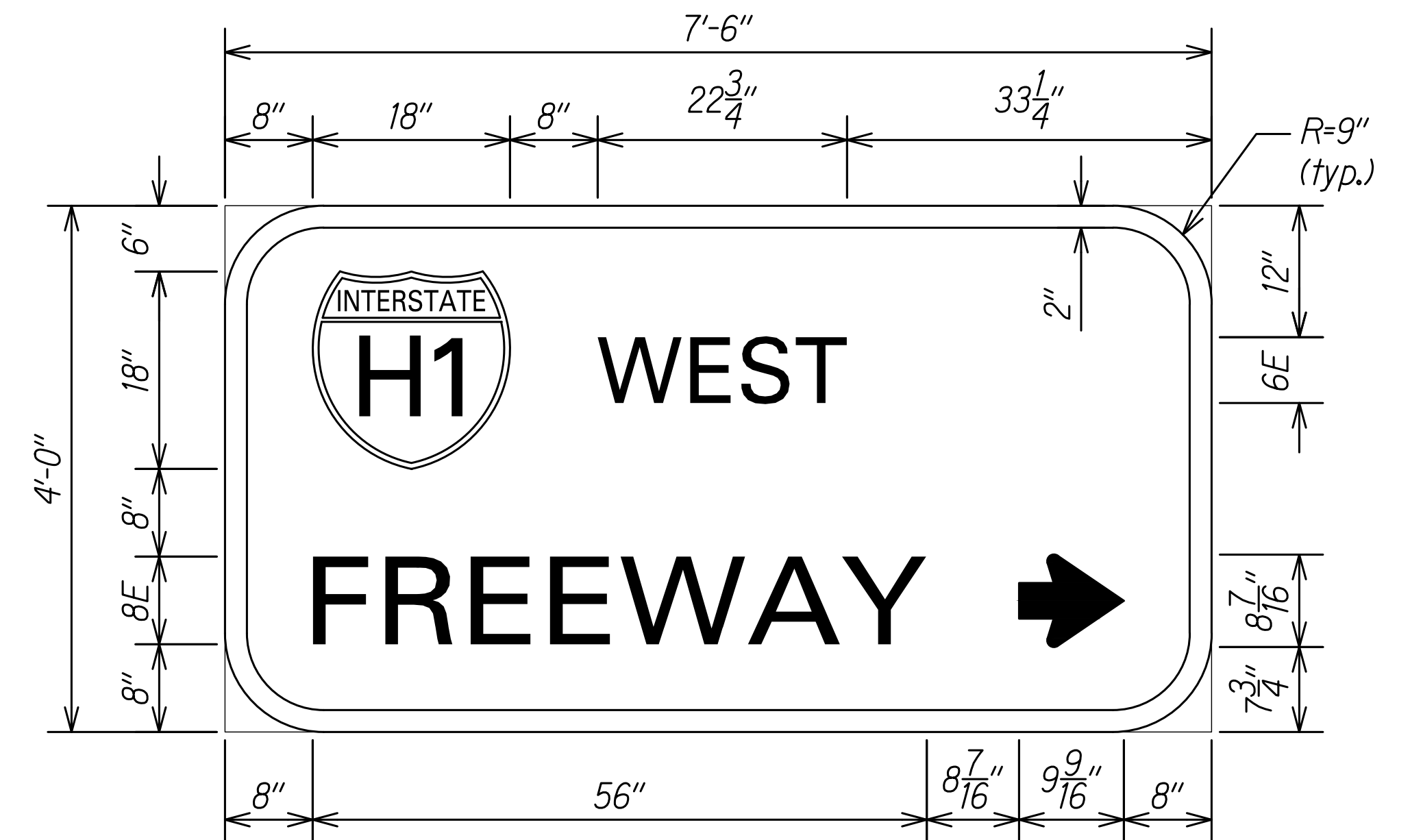

D-5
Not To Scale

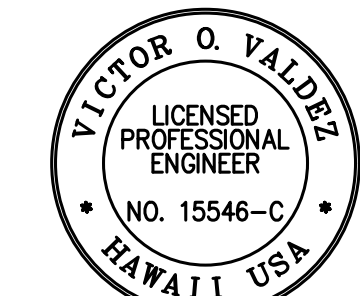

THIS WORK WAS PREPARED BY ME
OR UNDER MY SUPERVISION

SIGNATURE: *[Signature]* 04/30/22
EXPIRATION DATE OF THE LICENSE

STATE OF HAWAII
DEPARTMENT OF TRANSPORTATION
HIGHWAYS DIVISION

SIGNAGE DETAILS

INTERSTATE ROUTE H-1 RESURFACING
Miller Pedestrian Overpass to Kapiolani Interchange
Federal-Aid Project No. NH-H1-1(279)

Scale: Not to Scale Date: August 2021

C:\PROJECTS\2016_2022\000_DOT-HWYS_H1_RESURFACING - MILLER TO KAPITNY01 CIVIL DRAWINGS\M30-M34_SIGN_PANEL_DETAILS.DWG 9/1/2020 3:46 PM

FED. ROAD DIST. NO.	STATE	FED. AID PROJ. NO.	FISCAL YEAR	SHEET NO.	TOTAL SHEETS
HAWAII	HAW.	NH-H1-1(279)	2021	172	304

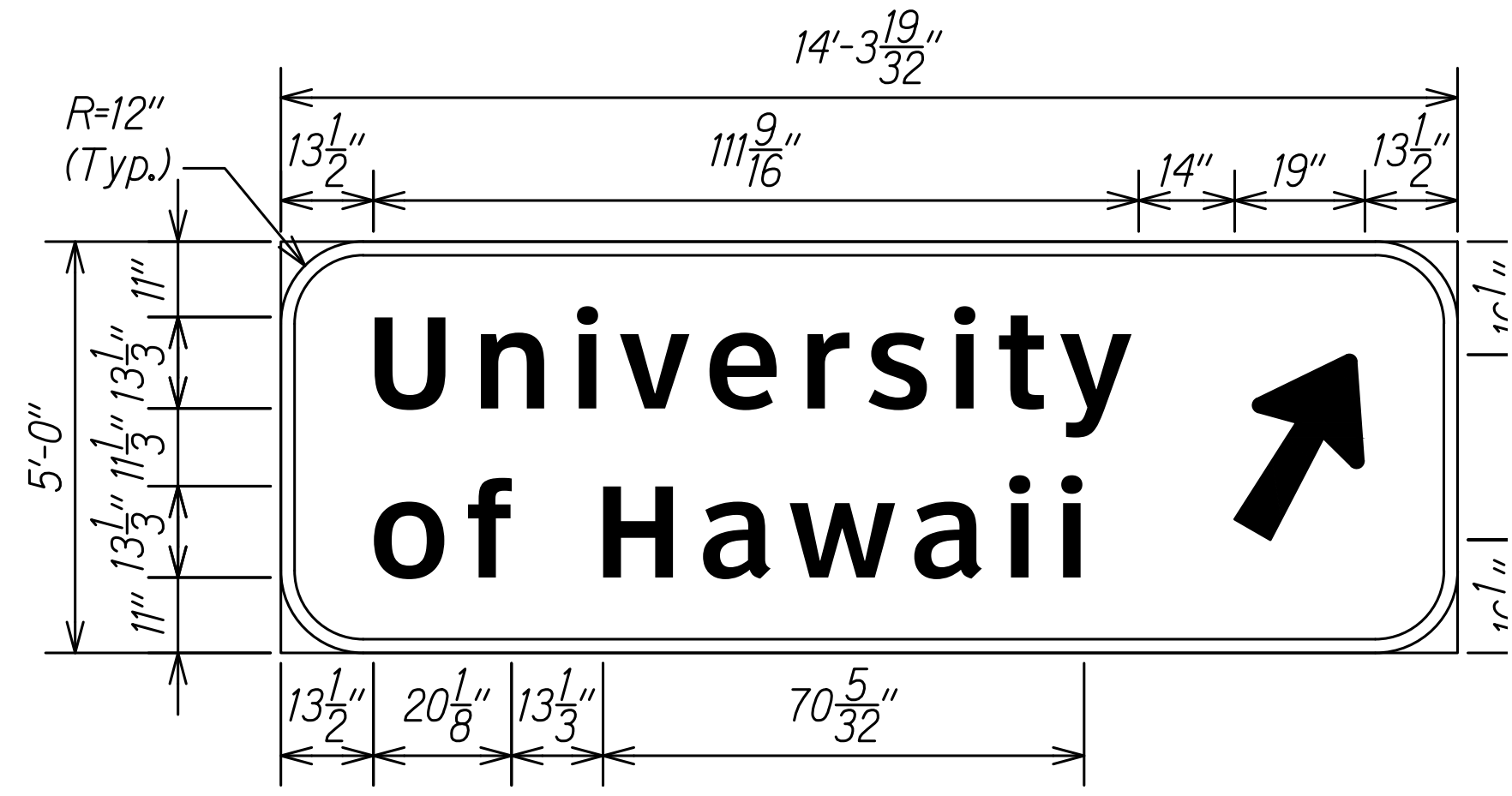

D-6
Not To Scale

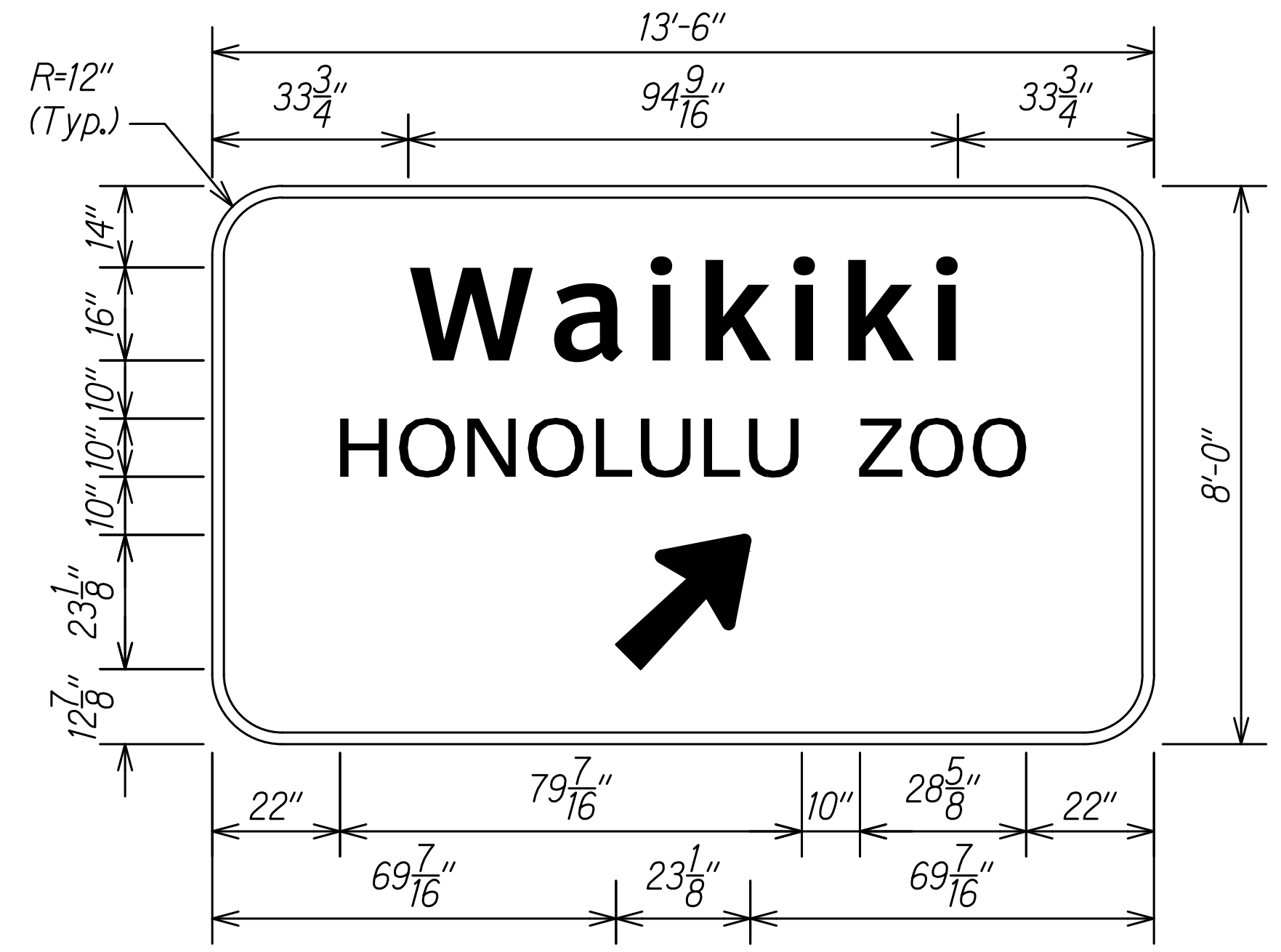

D-7
Not To Scale

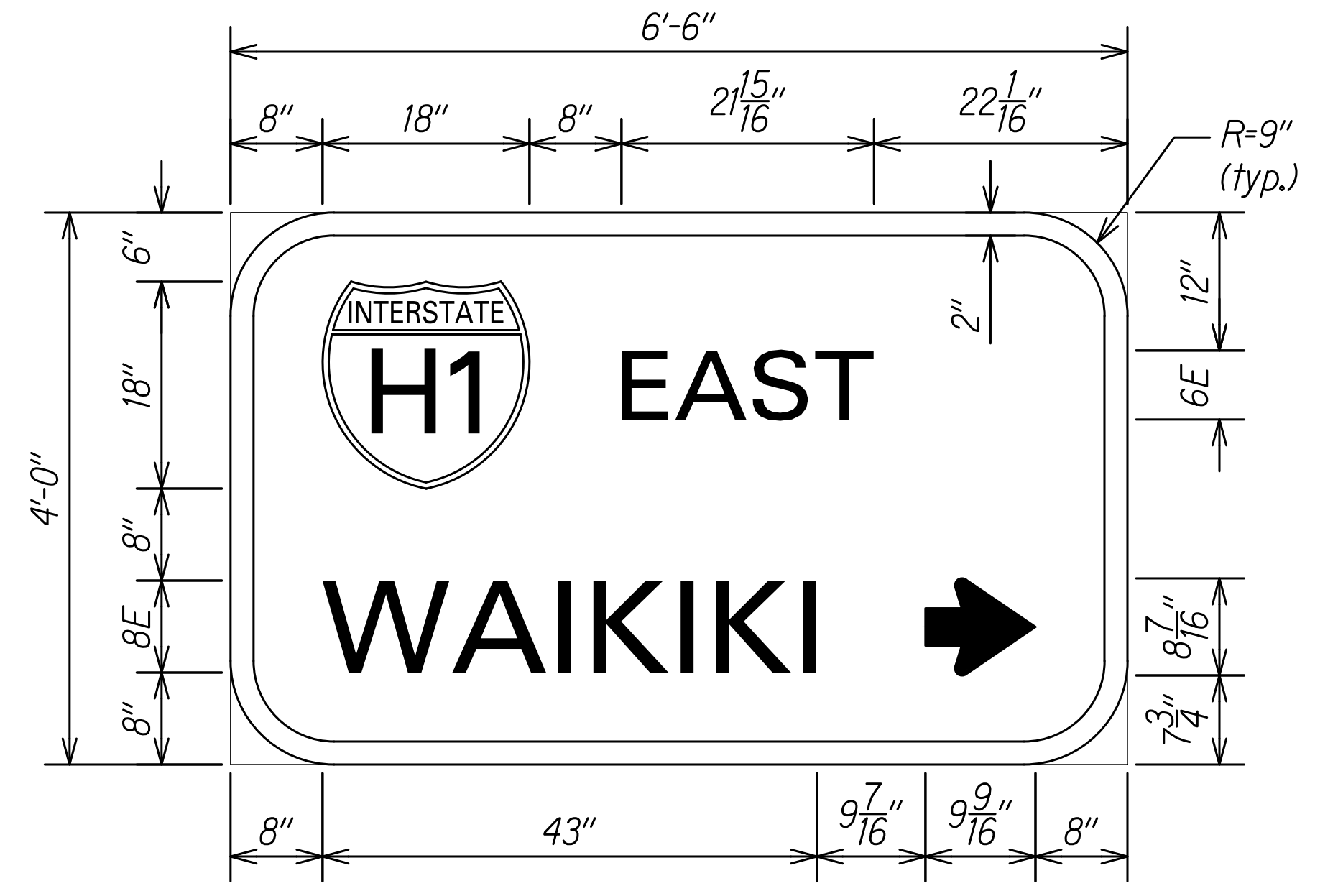

D-8
Not To Scale

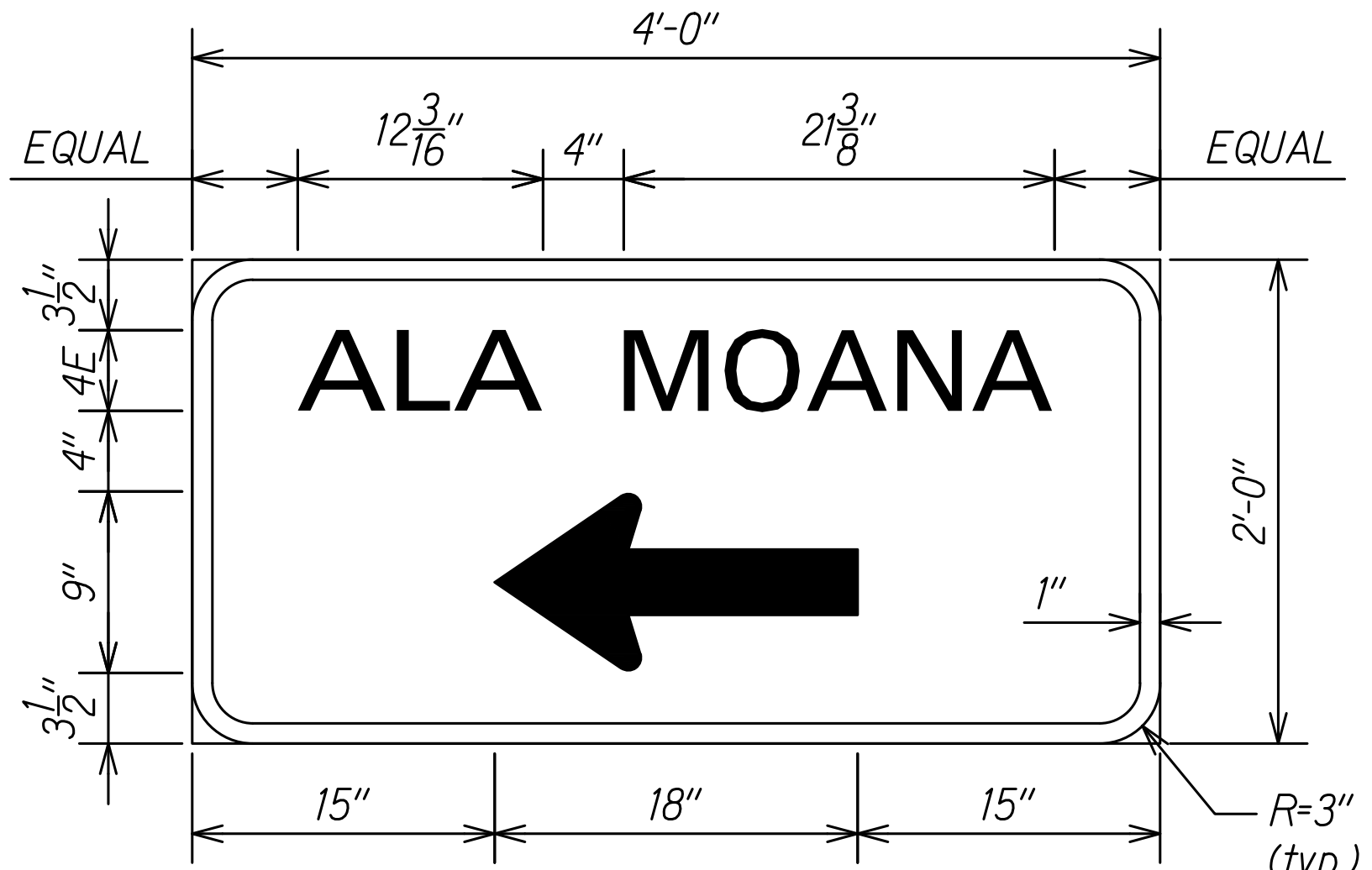

D-9
Not To Scale

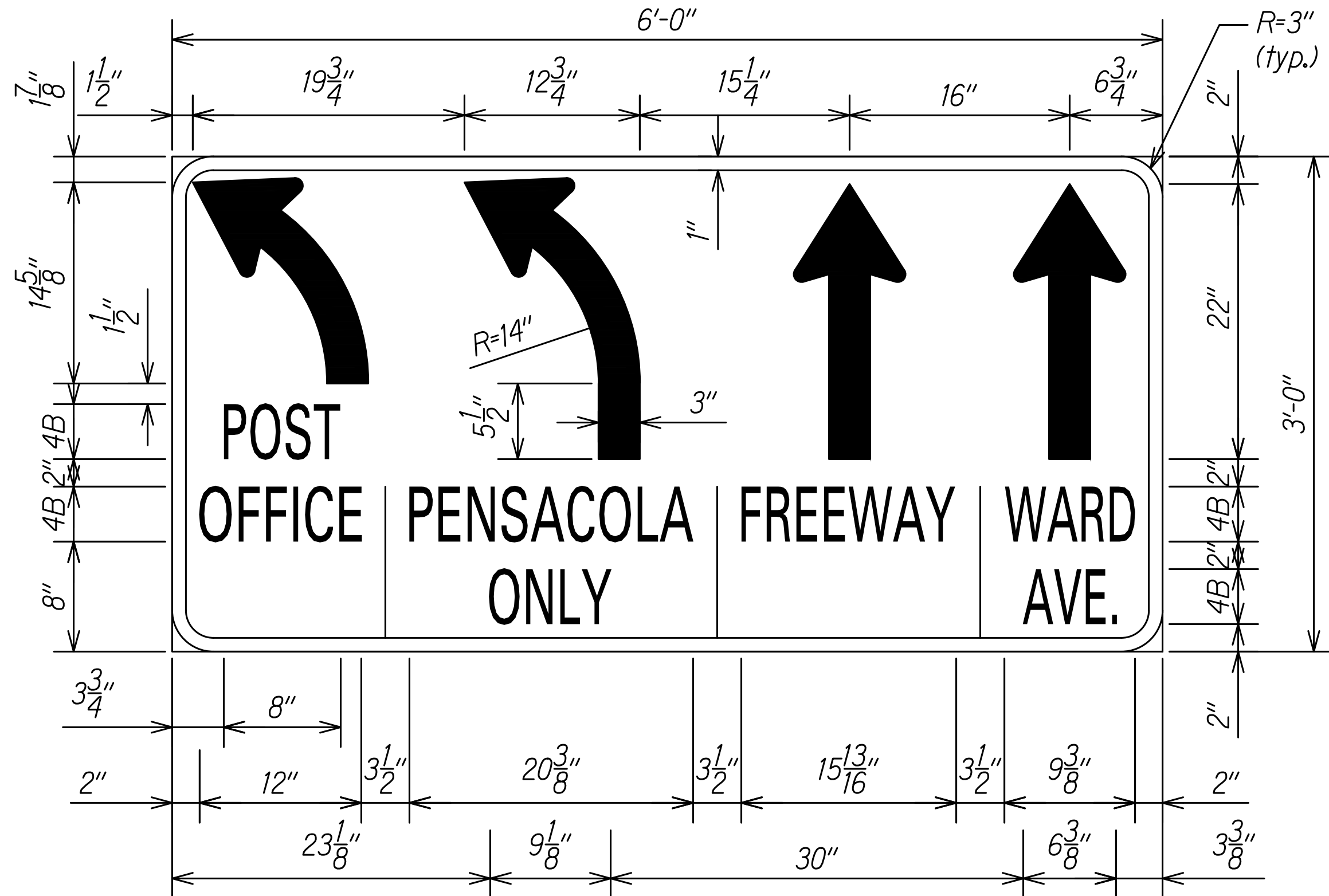

D-10
Not To Scale

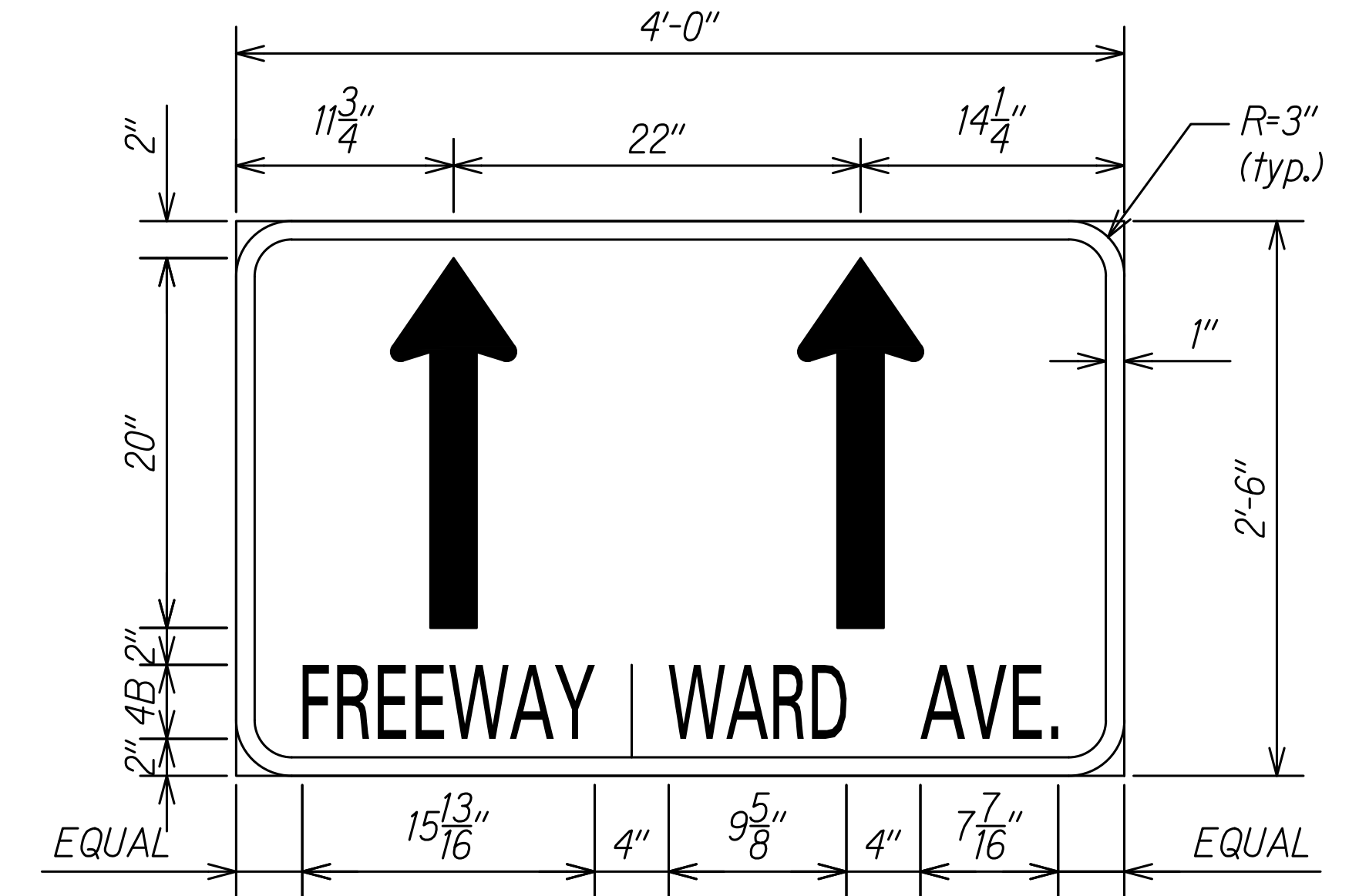

D-11
Not To Scale

C:_CIVIL_3D_PROJECTS\2016_2022\000_DOT-HWYS_H1_RESURFACING - MILLER TO KAPINUYO1 CIVIL DRAWINGS\M30-M34_SIGN_PANEL_DETAILS.DWG 9/1/2020 3:46 PM

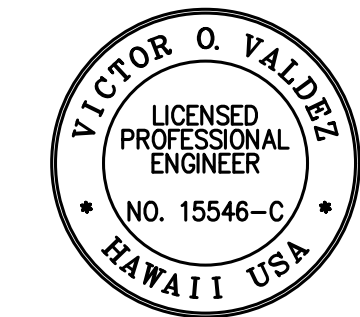

THIS WORK WAS PREPARED BY ME
OR UNDER MY SUPERVISION
[Signature]
SIGNATURE

04/30/22
EXPIRATION DATE
OF THE LICENSE

STATE OF HAWAII
DEPARTMENT OF TRANSPORTATION
HIGHWAYS DIVISION

SIGNAGE DETAILS

INTERSTATE ROUTE H-1 RESURFACING
Miller Pedestrian Overpass to Kapiolani Interchange
Federal-Aid Project No. NH-H1-1(279)

Scale: Not to Scale Date: August 2021

SHEET No. M31 OF 34 SHEETS

FED. ROAD DIST. NO.	STATE	FED. AID PROJ. NO.	FISCAL YEAR	SHEET NO.	TOTAL SHEETS
HAWAII	HAW.	NH-H1-1(279)	2021	173	304

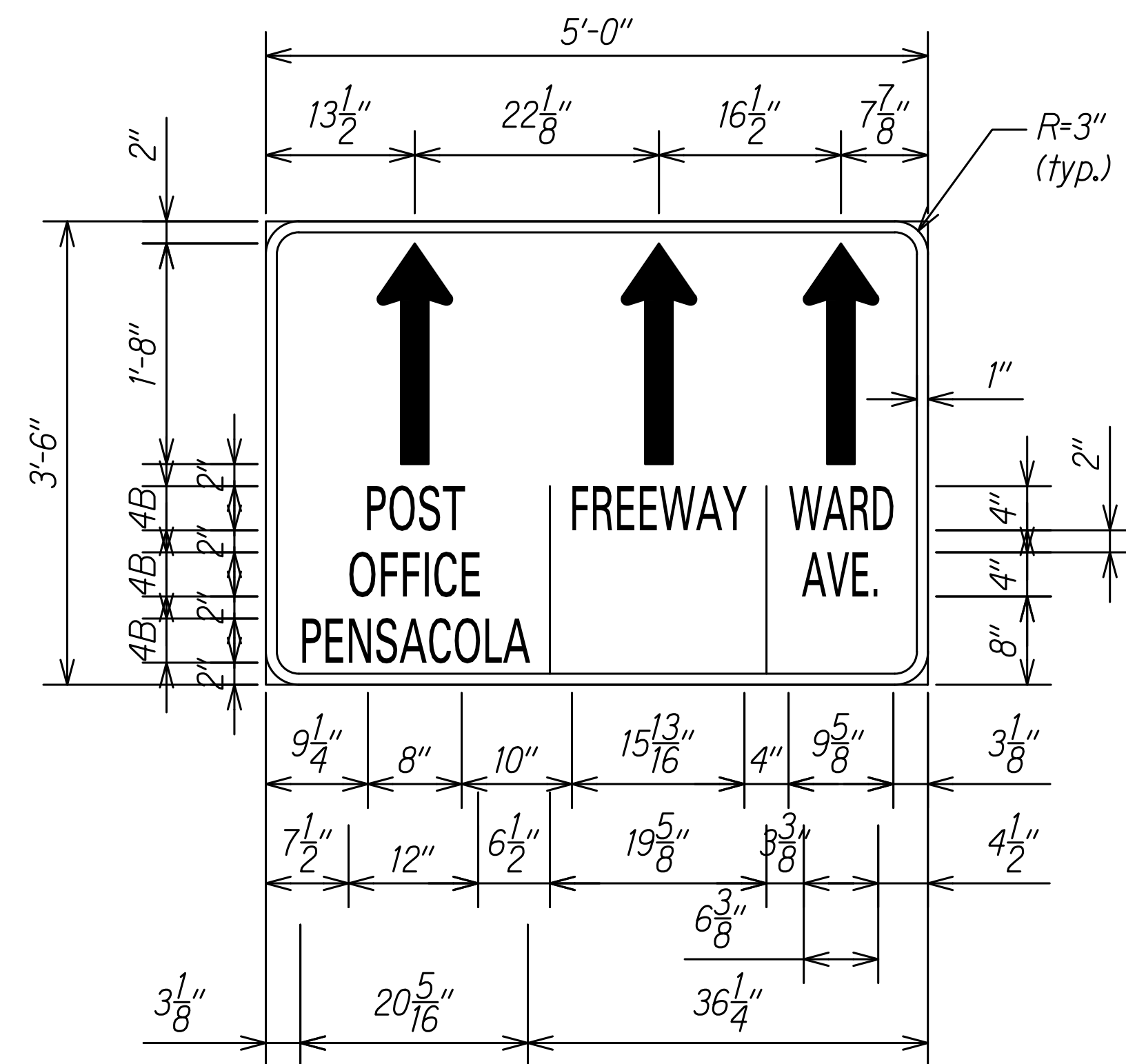

D-12
Not To Scale

4" White Edge Stripe
 8" White Stripe (Tape, Type I or Thermoplastic Extrusion)
 Milepost Number (Tape, Type I or Thermoplastic Extrusion)

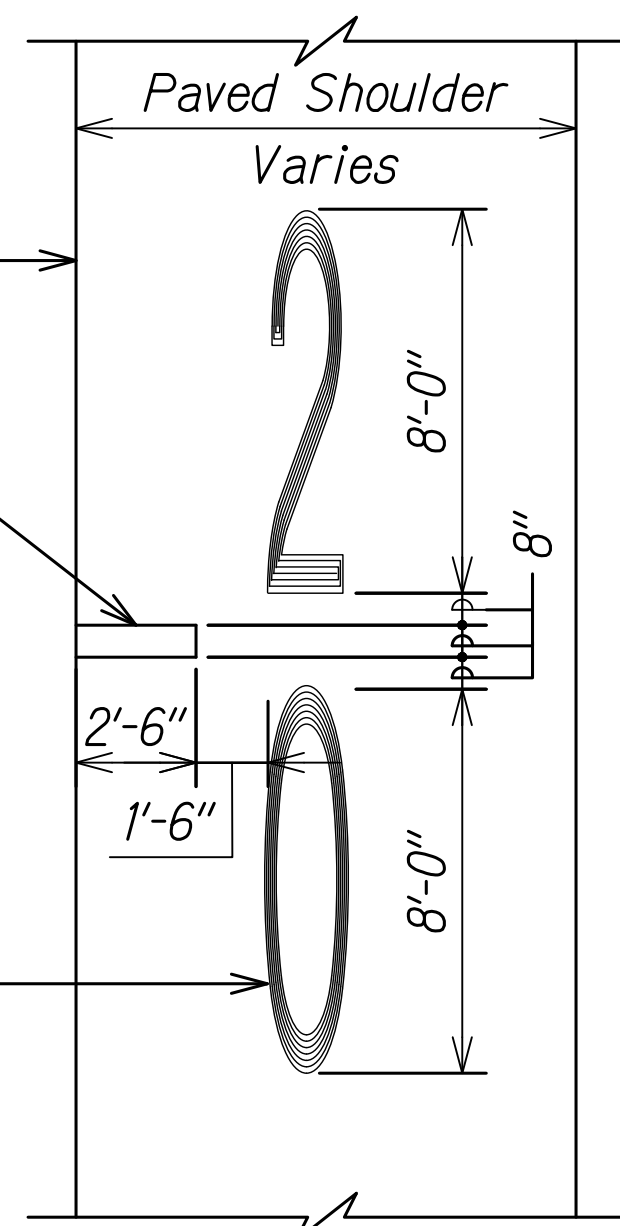

NOTE:
 Milepost Pavement Markings to be made under Item No. 629.1400 - Pavement Word Marking (Tape, Type I of Thermoplastic Extrusion)

TYPICAL MILEPOST PAVEMENT MARKING DETAIL
 Not to Scale

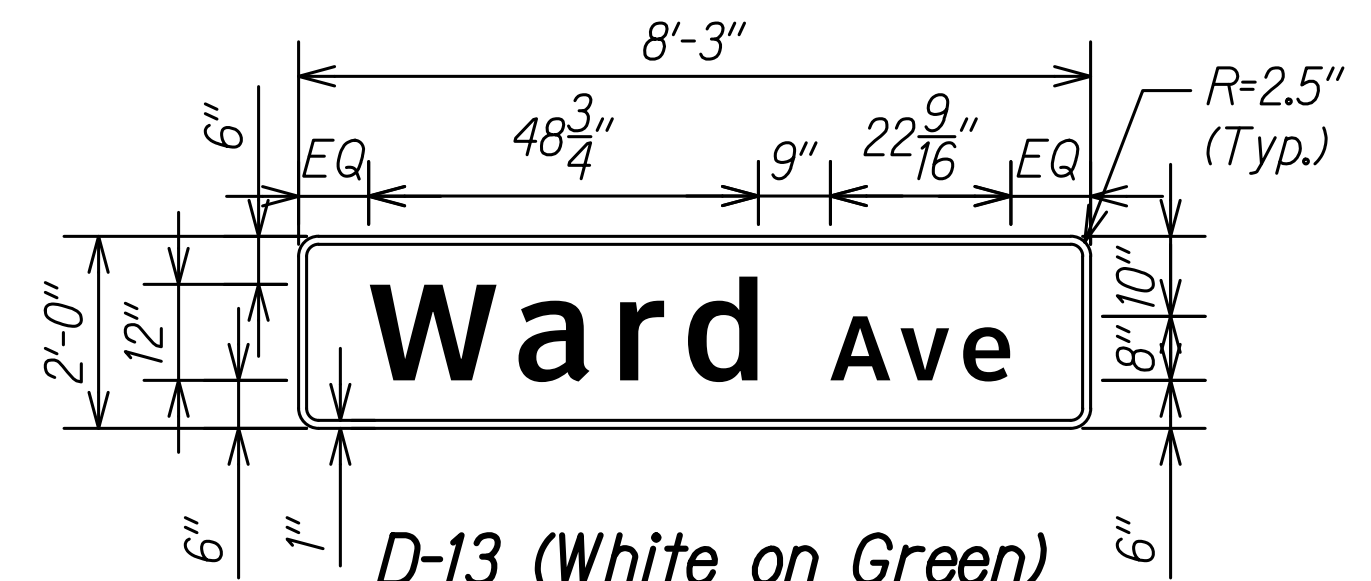

D-13 (White on Green)
 Scale: 1/2" = 1'-0"

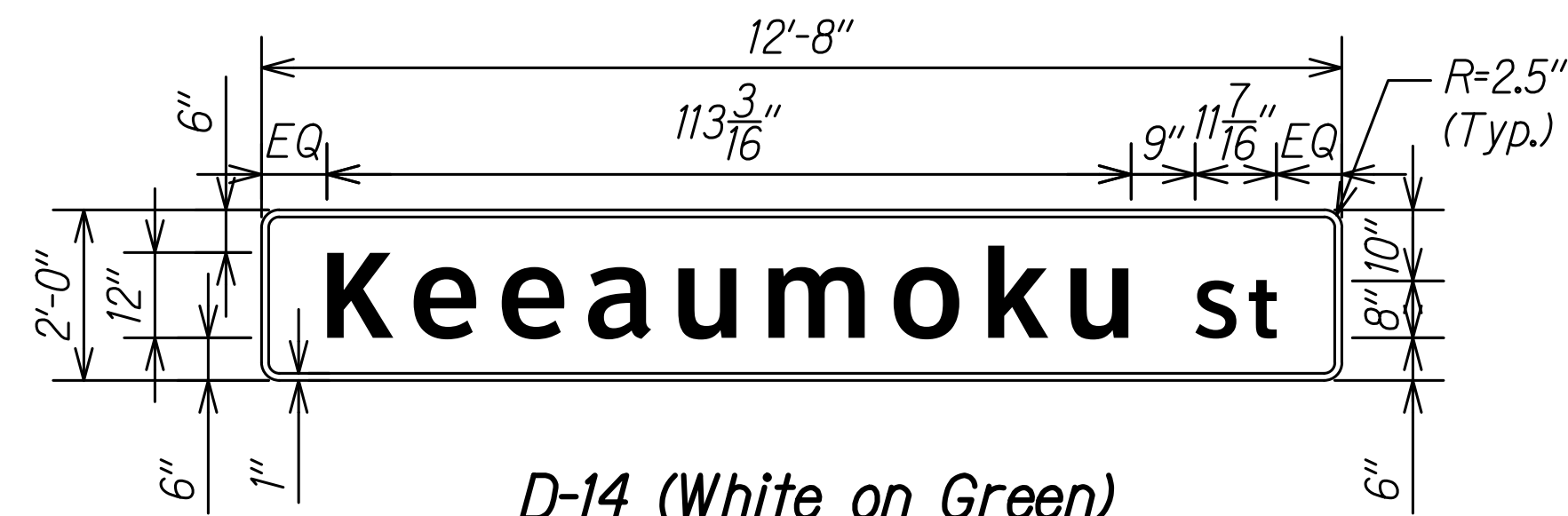

D-14 (White on Green)
 Scale: 1/2" = 1'-0"

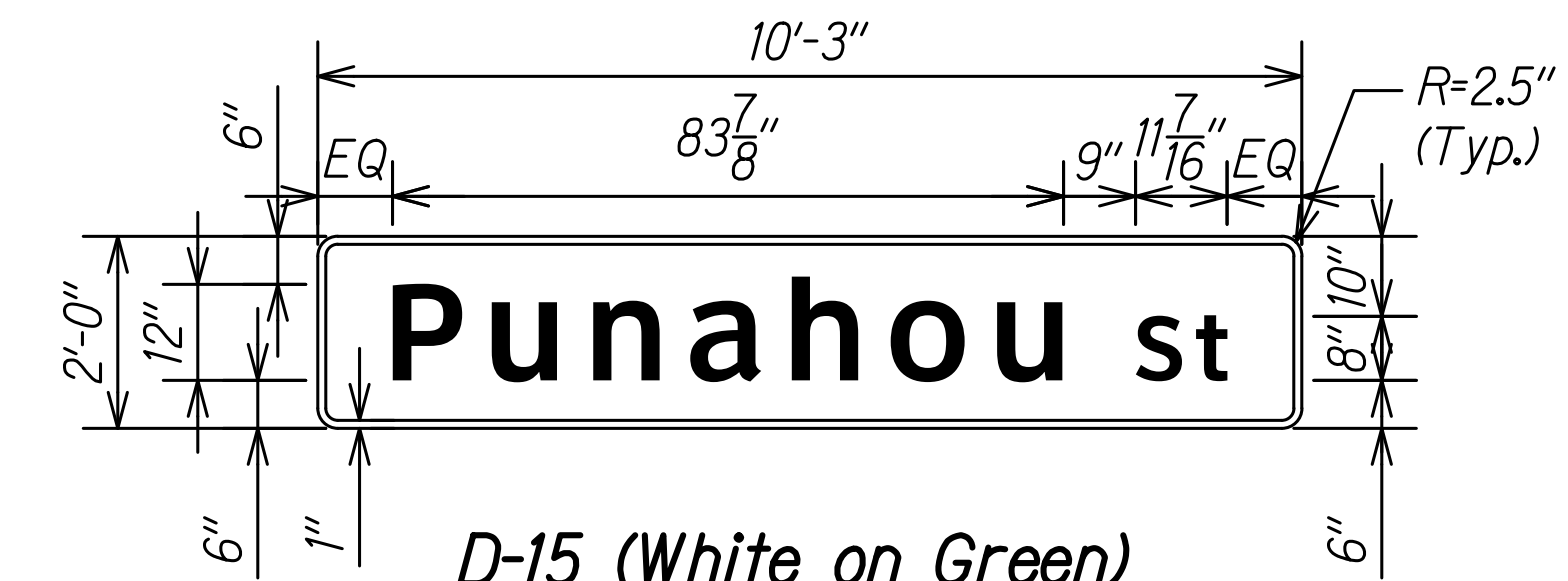

D-15 (White on Green)
 Scale: 1/2" = 1'-0"

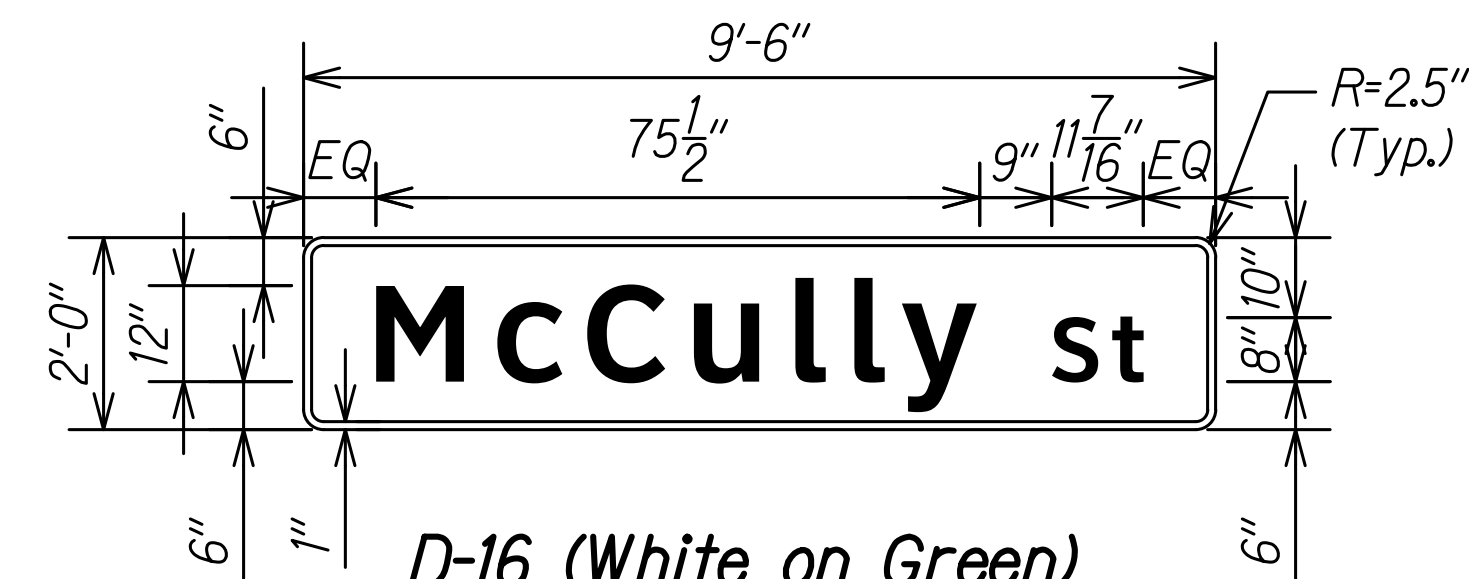

D-16 (White on Green)
 Scale: 1/2" = 1'-0"

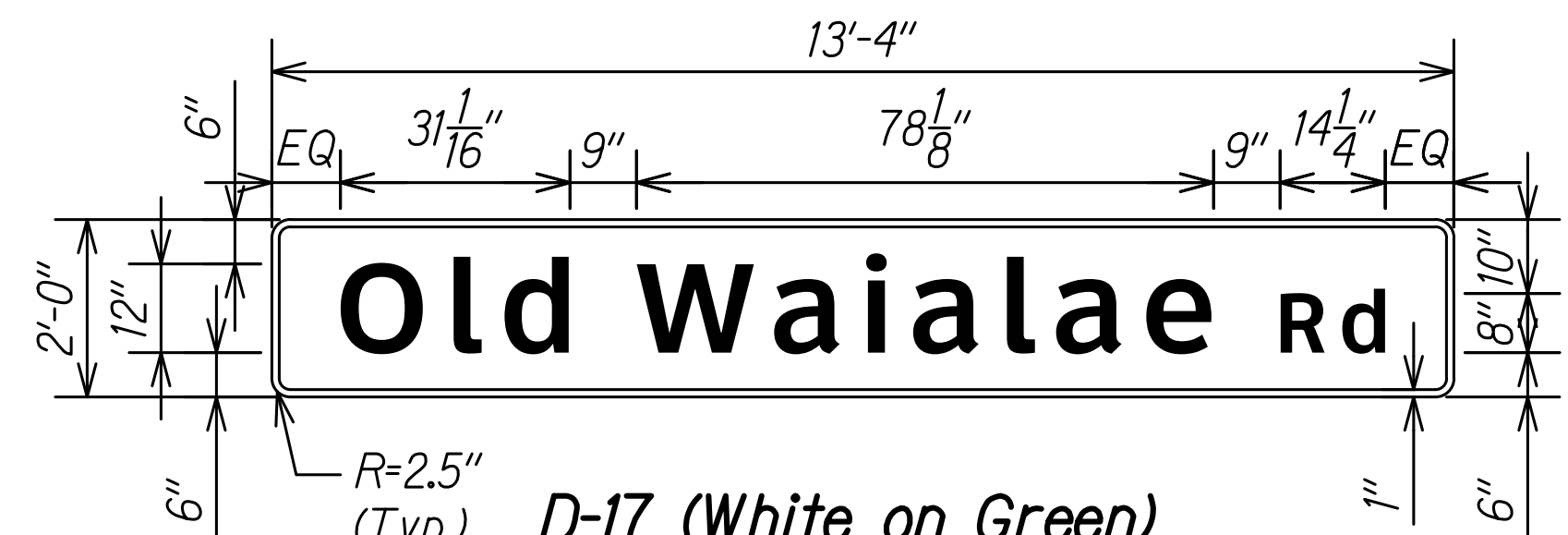

D-17 (White on Green)
 Scale: 1/2" = 1'-0"

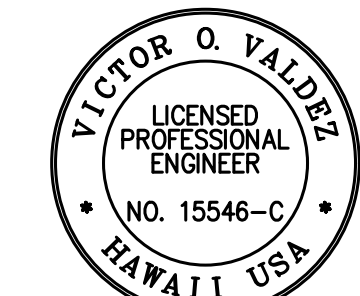

THIS WORK WAS PREPARED BY ME OR UNDER MY SUPERVISION
 SIGNATURE: *[Signature]* 04/30/22
 EXPIRATION DATE OF THE LICENSE

STATE OF HAWAII
 DEPARTMENT OF TRANSPORTATION
 HIGHWAYS DIVISION

SIGNAGE DETAILS

INTERSTATE ROUTE H-1 RESURFACING
 Miller Pedestrian Overpass to Kapiolani Interchange
 Federal-Aid Project No. NH-H1-1(279)

Scale: Not to Scale Date: August 2021

C:\PROJECTS\2016_2022\000_DOT-HWYS_H1_RESURFACING - MILLER TO KAPITV01 CIVIL DRAWINGS\M30-M34_SIGN_PANEL_DETAILS.DWG 9/1/2020 3:46 PM

FED. ROAD DIST. NO.	STATE	FED. AID PROJ. NO.	FISCAL YEAR	SHEET NO.	TOTAL SHEETS
HAWAII	HAW.	NH-H1-1(279)	2021	174	304

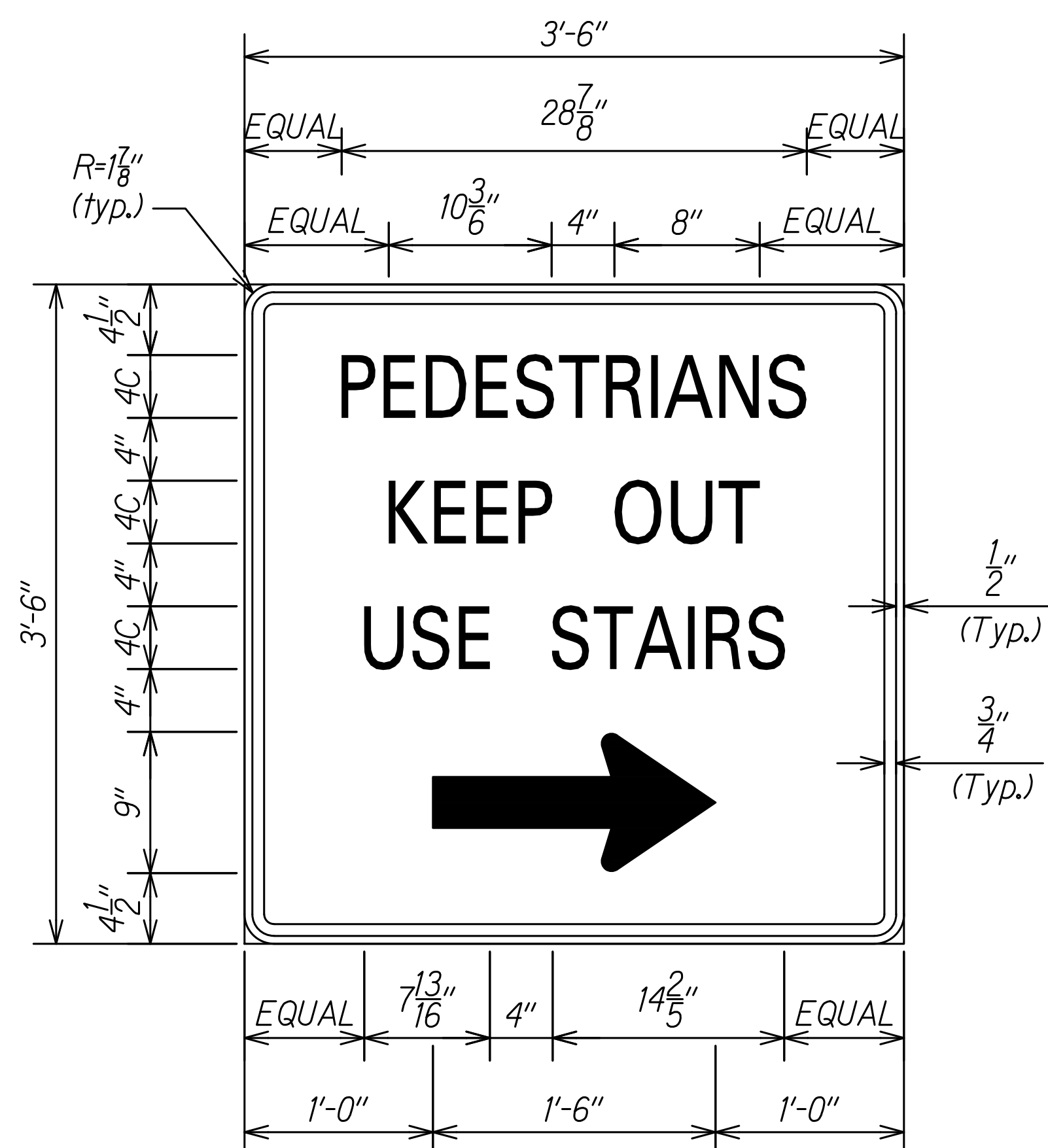

PEDESTRIAN KEEP OUT SIGN (Black on Orange)
Not To Scale

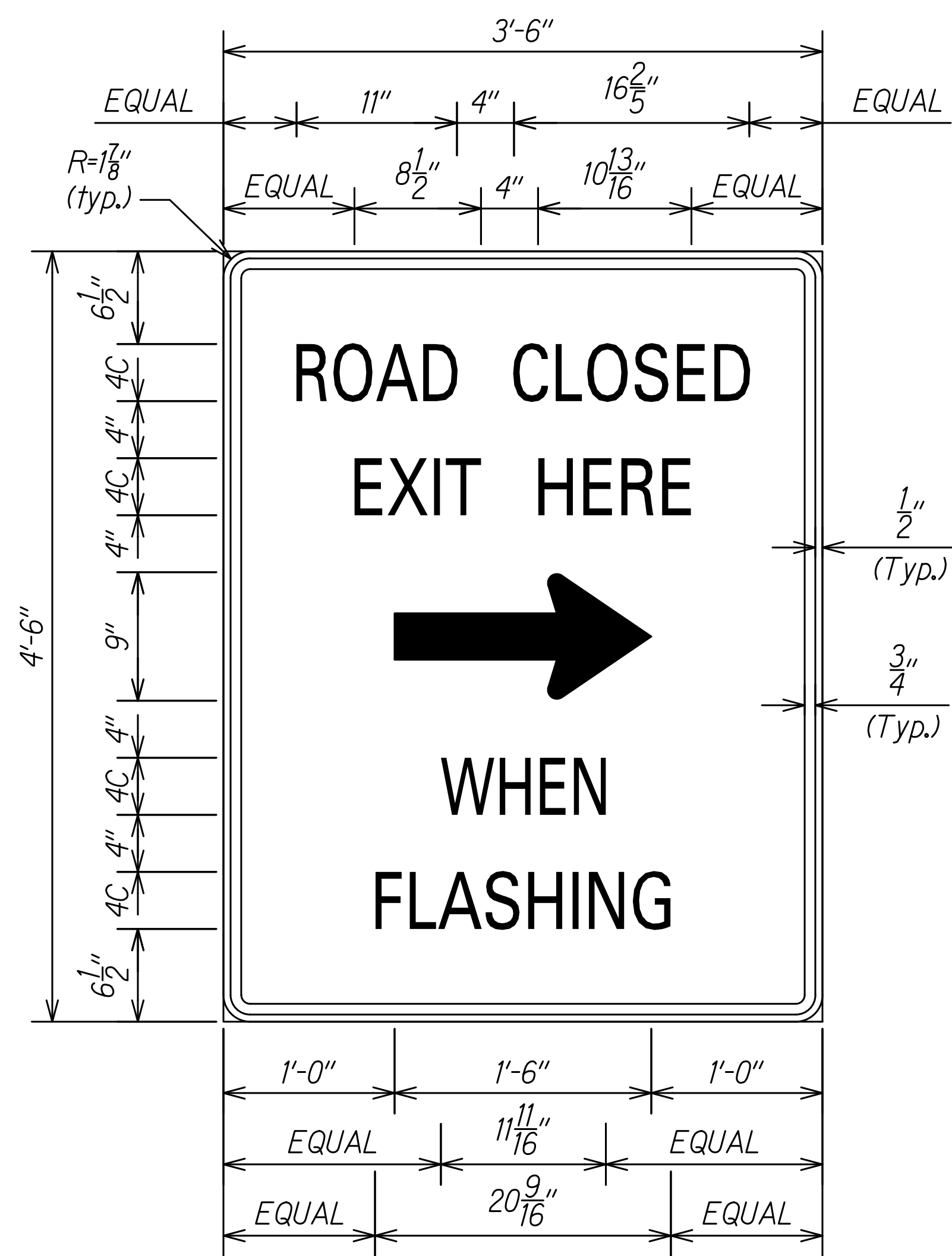

ROAD CLOSED SIGN (Black on Orange)
Not To Scale

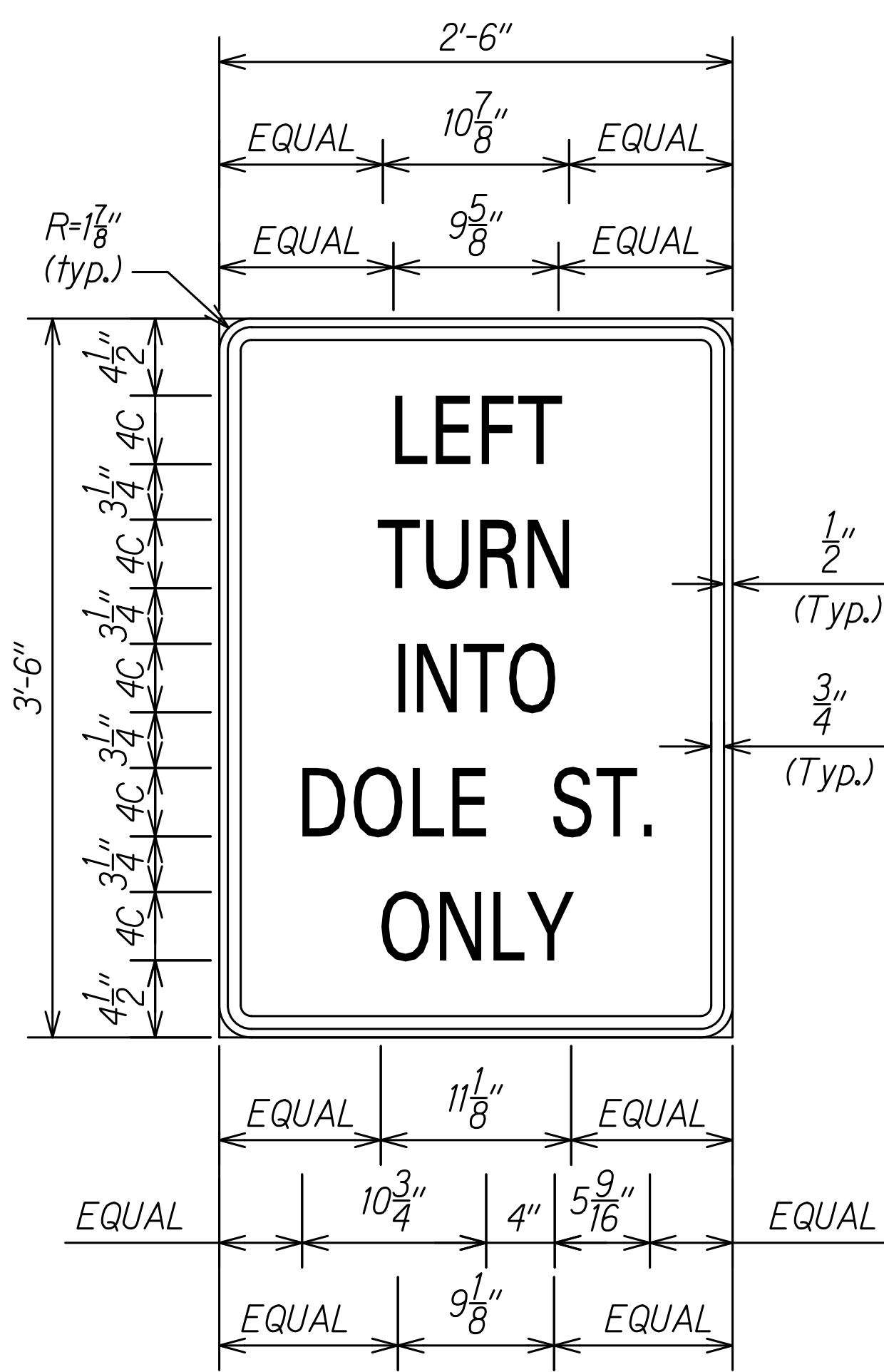

LEFT TURN SIGN (Black on White)
Not To Scale

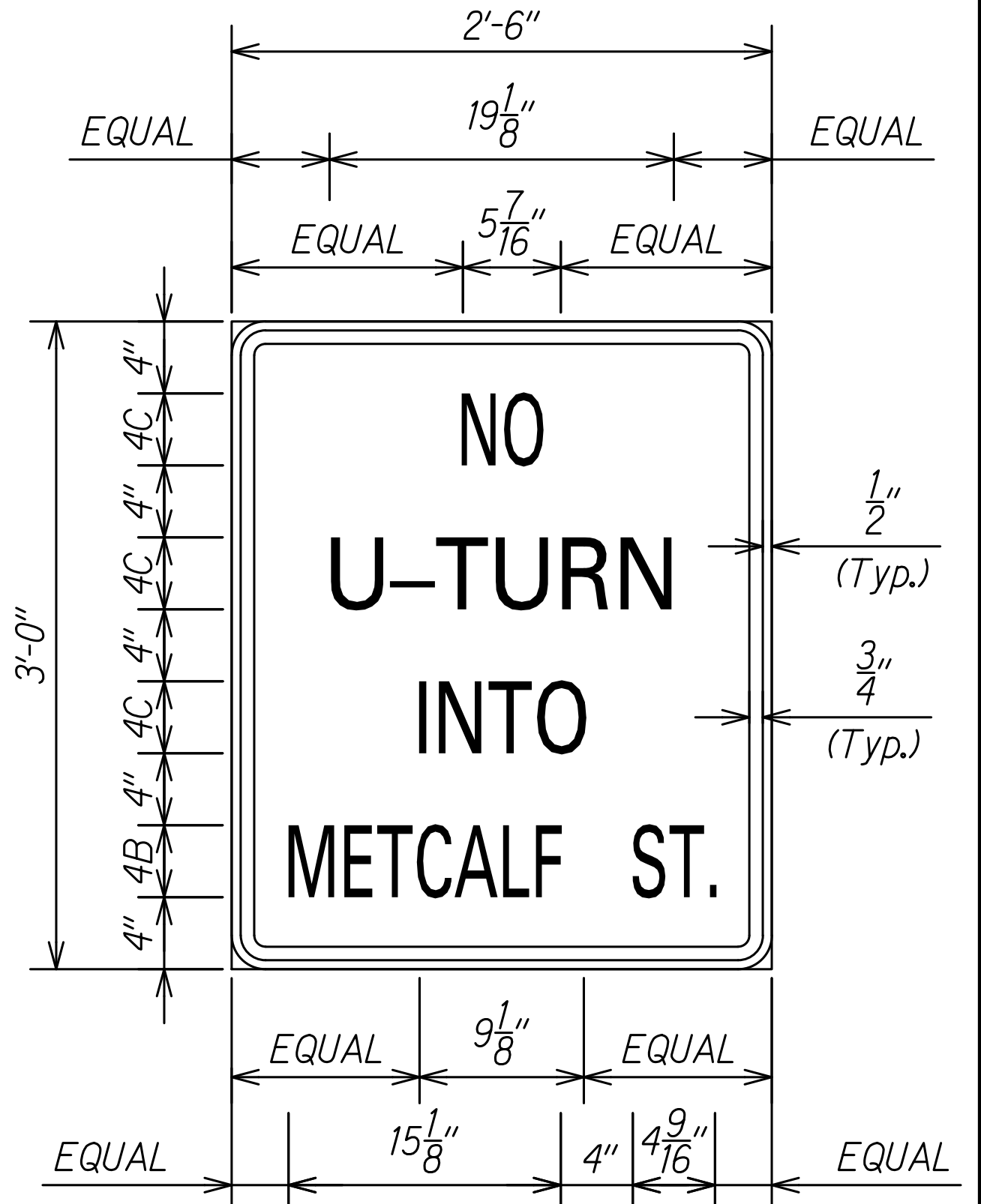

NO U-TURN SIGN (Black on White)
Not To Scale

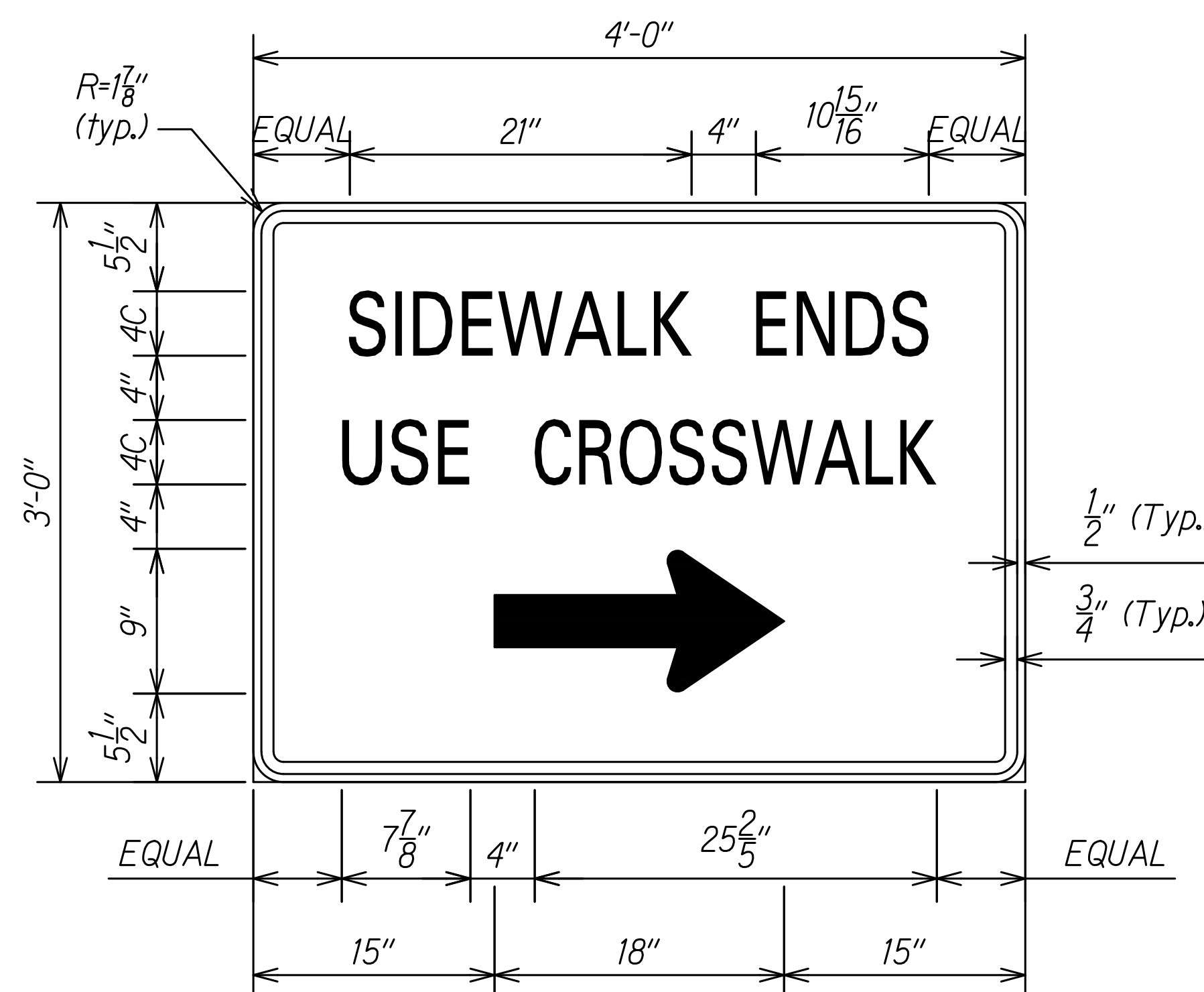

R9-3b (R) (MOD.) (Black on White)
Not To Scale

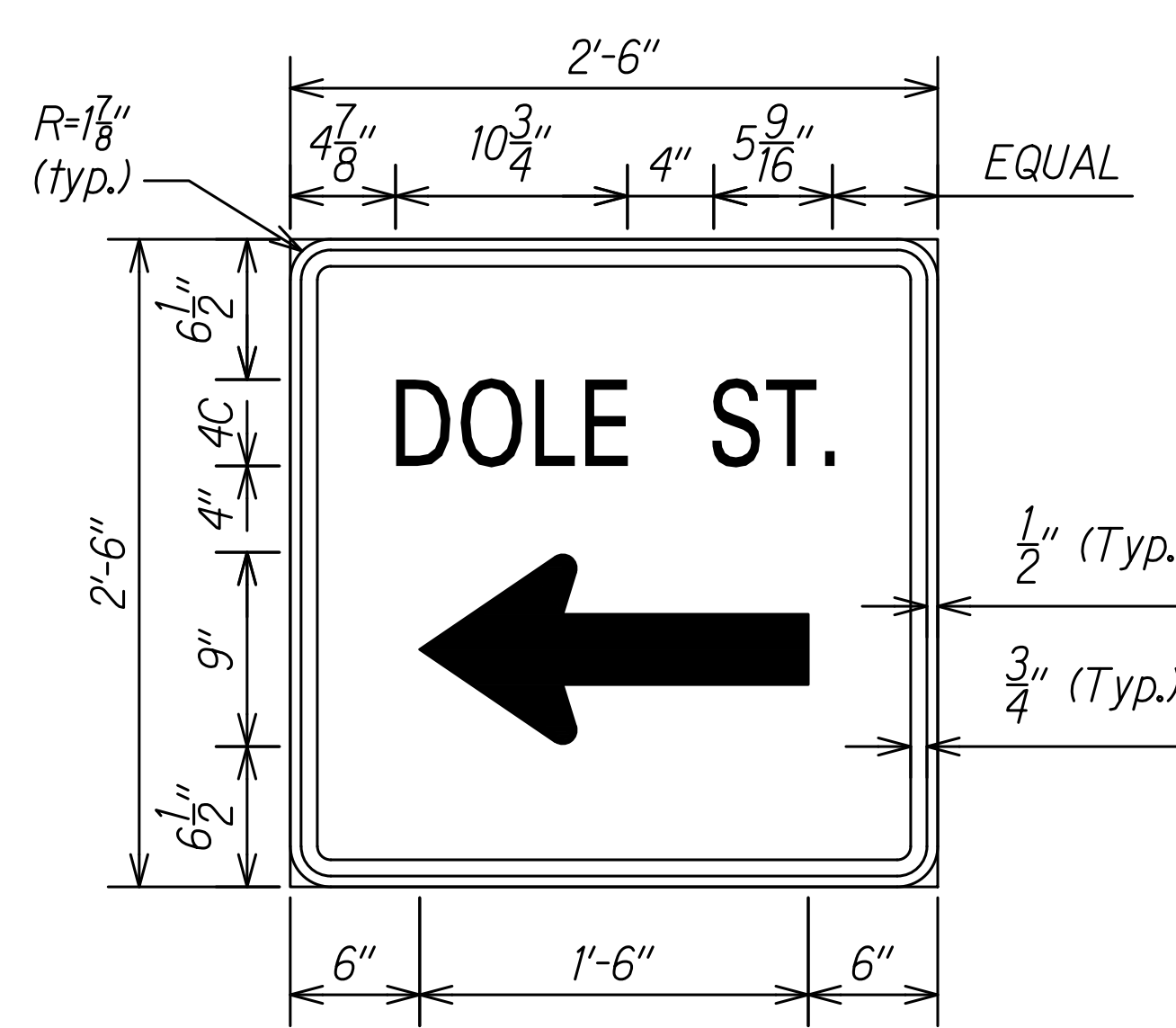

DIRECTIONAL SIGN (Black on White)
Not To Scale

NOTE:
Lettering shall be centered and shall be 4" Series C letters.

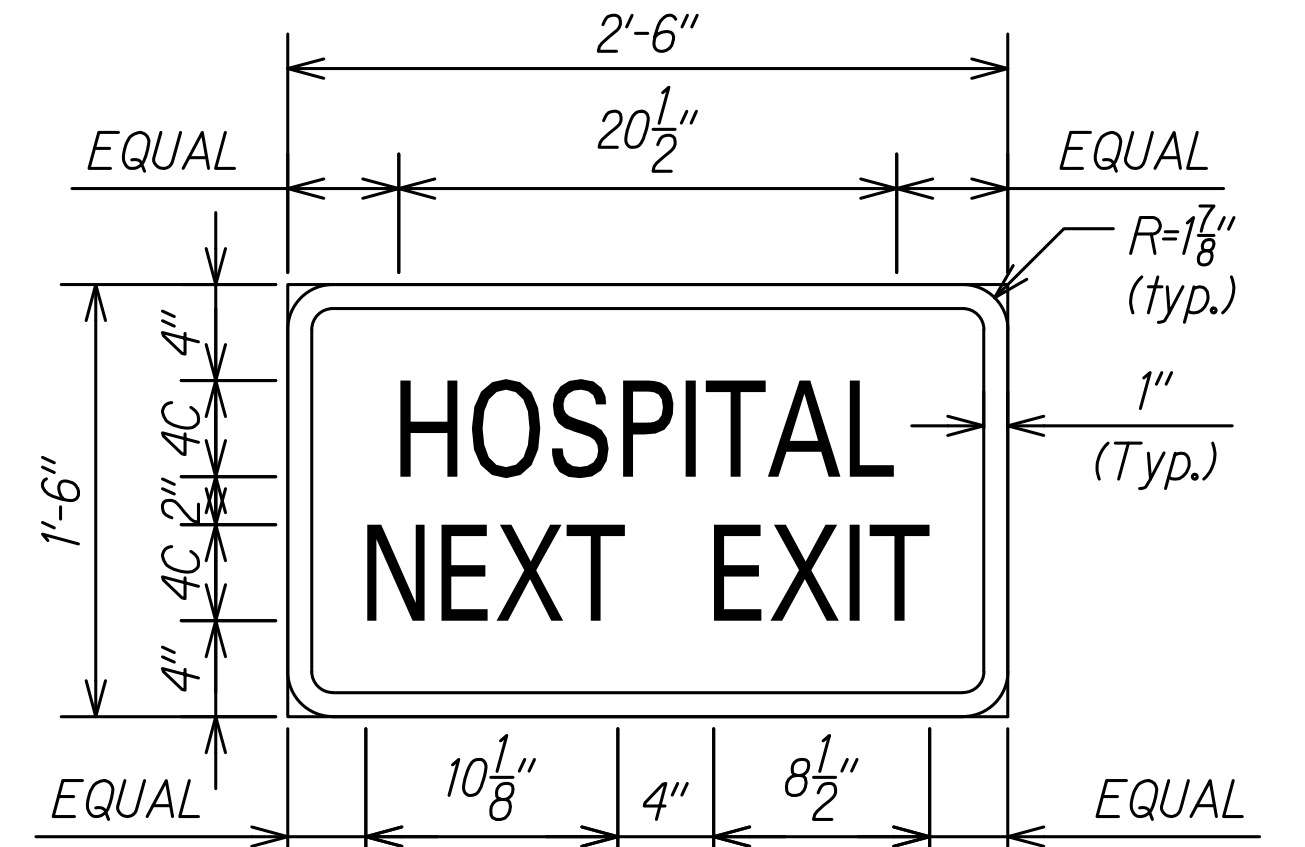

HOSPITAL SIGN (White on Blue)
Not To Scale

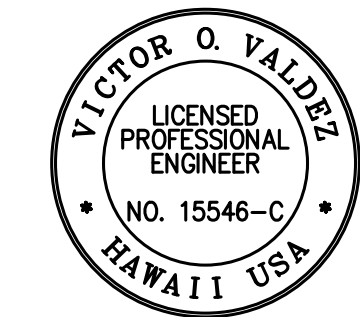

THIS WORK WAS PREPARED BY ME OR UNDER MY SUPERVISION
 SIGNATURE: *[Signature]* 04/30/22
 EXPIRATION DATE OF THE LICENSE

STATE OF HAWAII
 DEPARTMENT OF TRANSPORTATION
 HIGHWAYS DIVISION

SIGNAGE DETAILS

INTERSTATE ROUTE H-1 RESURFACING
 Miller Pedestrian Overpass to Kapiolani Interchange
 Federal-Aid Project No. NH-H1-1(279)

Scale: Not to Scale Date: August 2021

C:_CIVIL_3D_PROJECTS\2016_2022\000_DOT-HWYS_H1_RESURFACING - MILLER TO KAPINUI CIVIL DRAWINGS\M30-M34_SIGN_PANEL_DETAILS.DWG_9/1/2020_3:46 PM

FED. ROAD DIST. NO.	STATE	FED. AID PROJ. NO.	FISCAL YEAR	SHEET NO.	TOTAL SHEETS
HAWAII	HAW.	NH-H1-1(279)	2021	175	304

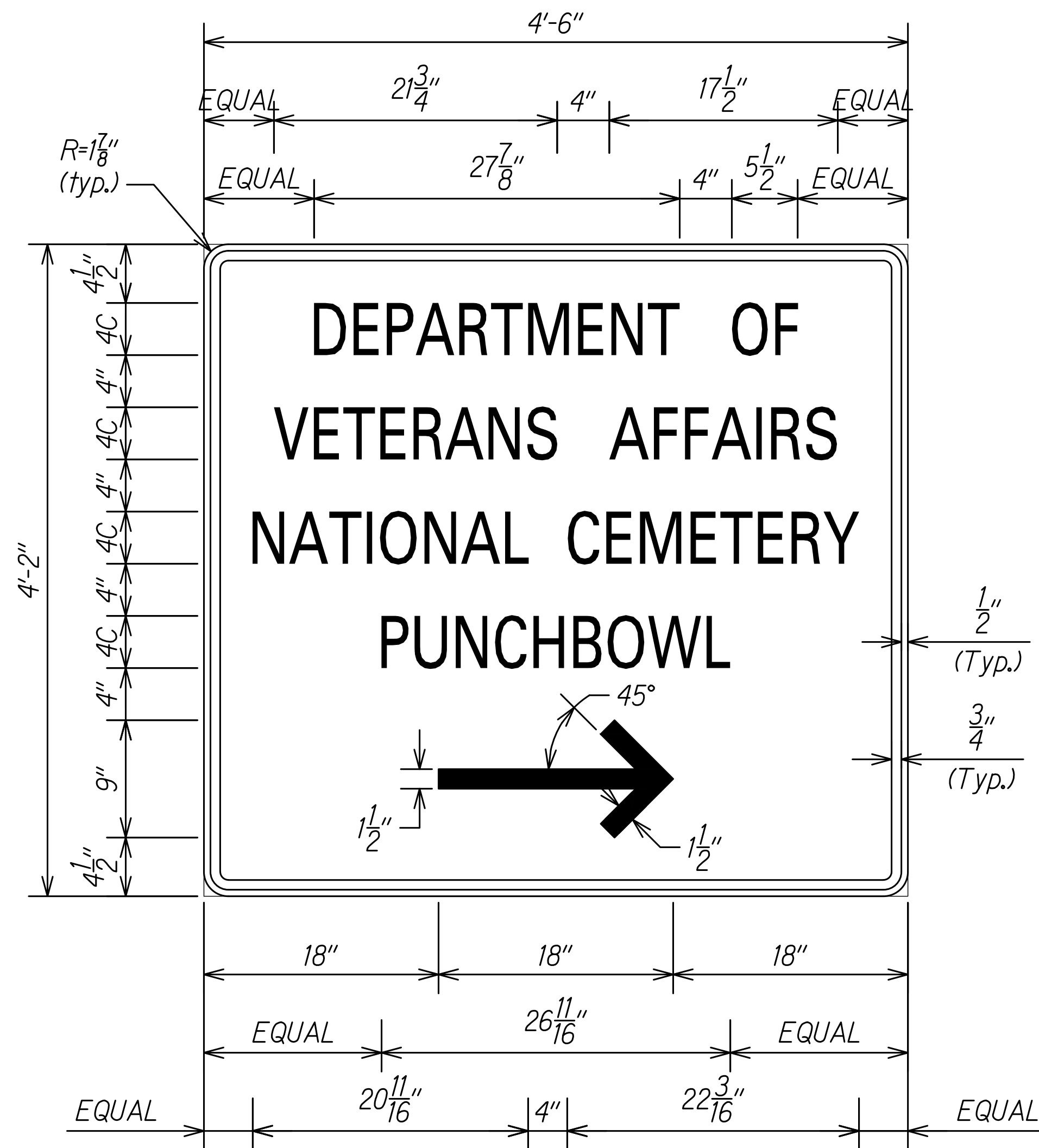

NATIONAL CEMETERY SIGN
Not To Scale

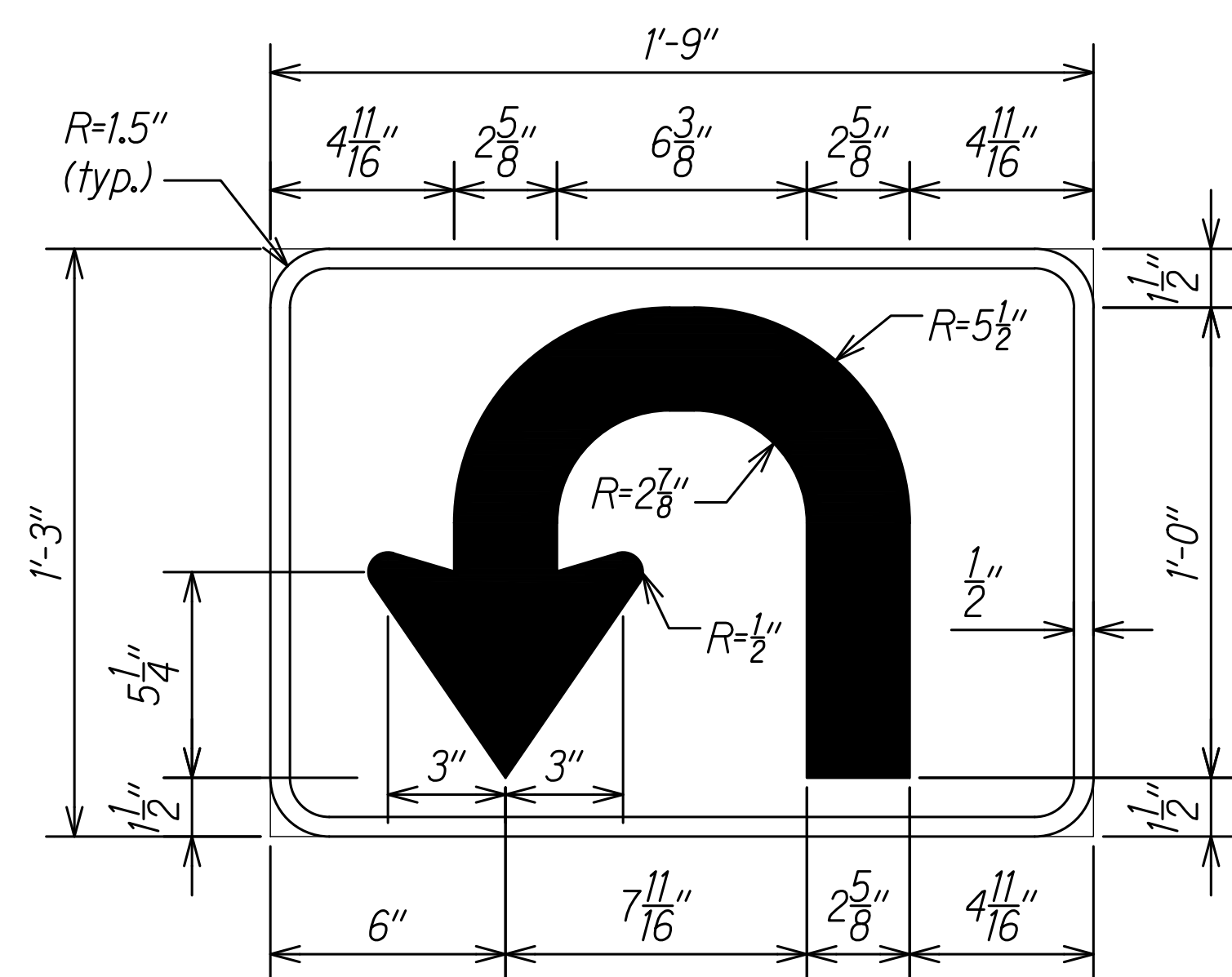

U-TURN ARROW SIGN
Not To Scale

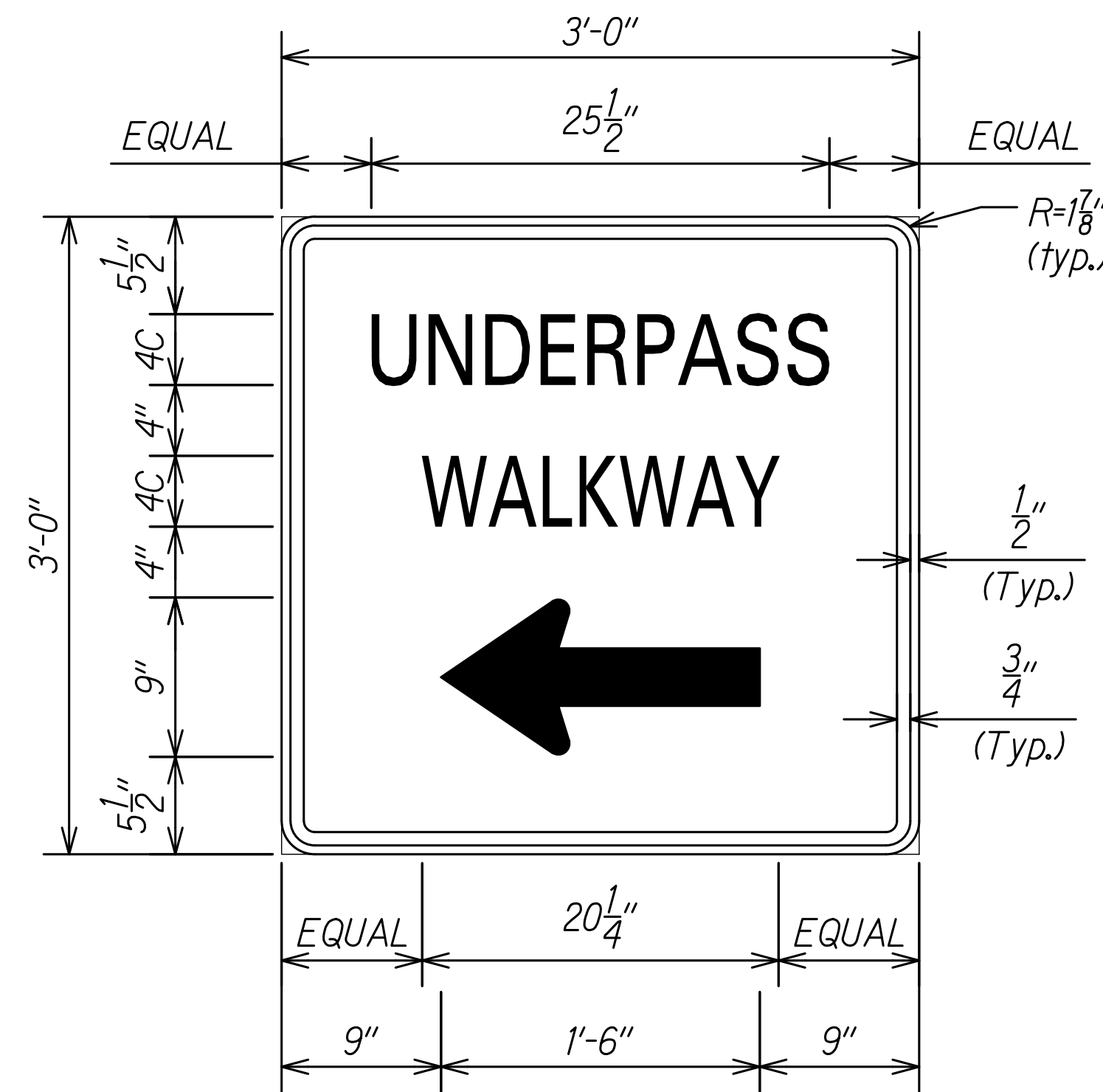

UNDERPASS WALKWAY SIGN (Black on White)
Not To Scale

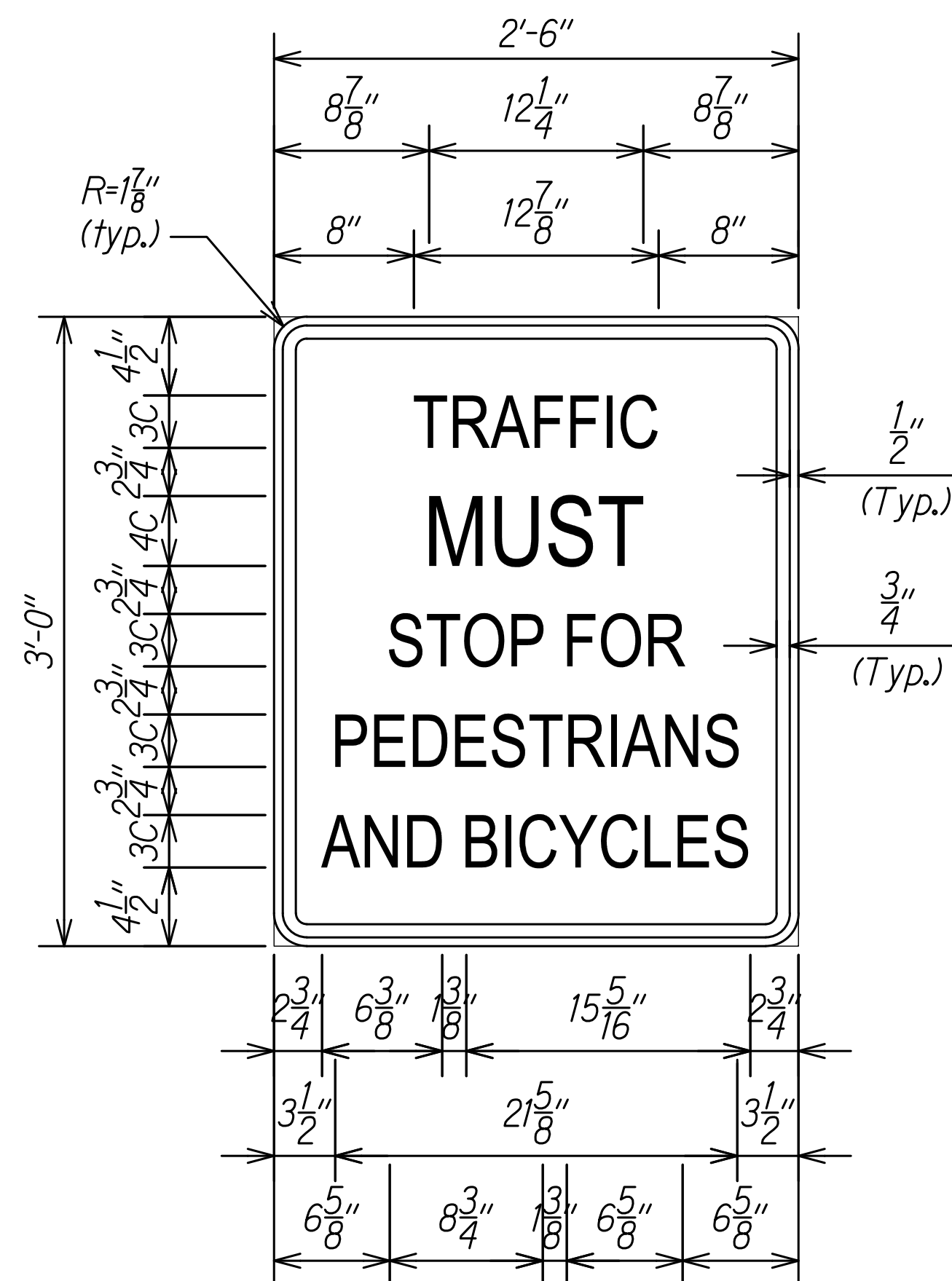

TRAFFIC MUST STOP SIGN (Black on White)
Not To Scale

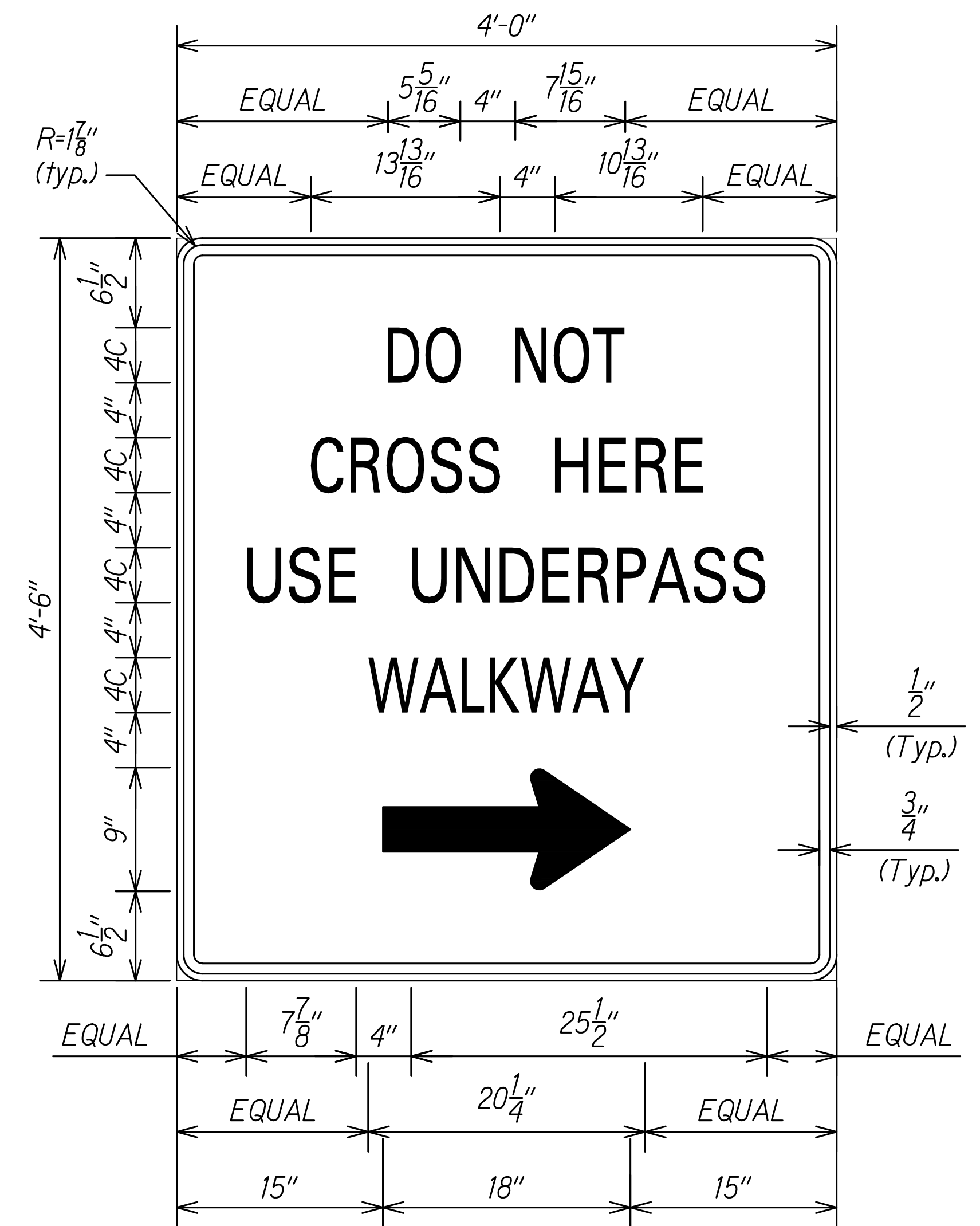

DO NOT CROSS SIGN (Black on White)
Not To Scale

NOTE:
Lettering shall be centered and shall be 4" Series C letters.



THIS WORK WAS PREPARED BY ME OR UNDER MY SUPERVISION

SIGNATURE: *[Signature]* 04/30/22
EXPIRATION DATE OF THE LICENSE

STATE OF HAWAII
DEPARTMENT OF TRANSPORTATION
HIGHWAYS DIVISION

SIGNAGE DETAILS

INTERSTATE ROUTE H-1 RESURFACING
Miller Pedestrian Overpass to Kapiolani Interchange
Federal-Aid Project No. NH-H1-1(279)

Scale: Not to Scale Date: August 2021

SHEET No. M34 OF 34 SHEETS