

FED. ROAD DIST. NO.	STATE	PROJ. NO.	FISCAL YEAR	SHEET NO.	TOTAL SHEETS
HAWAII	HAW.	440B-01-11M	2011	10	16

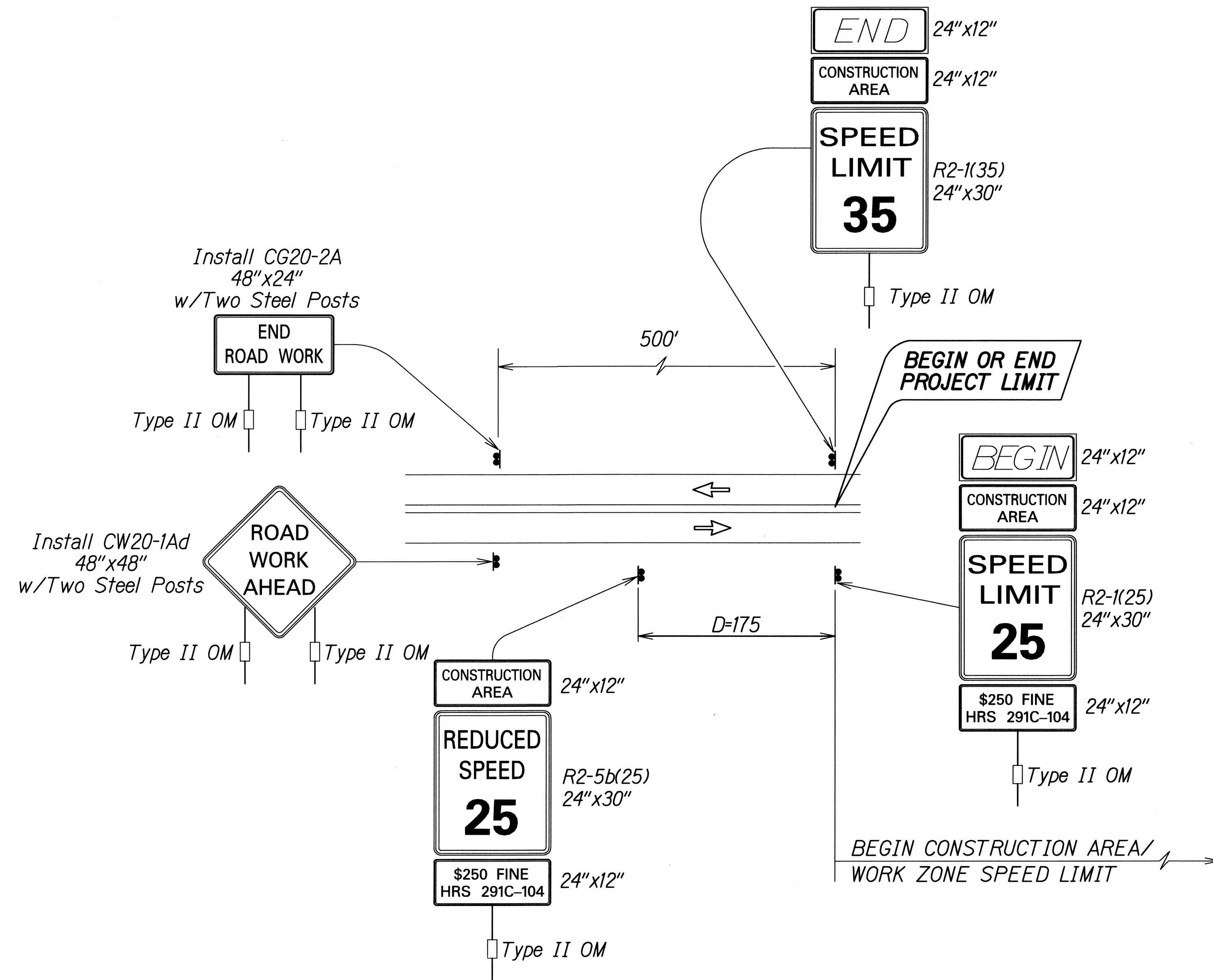

**TYPICAL DETAIL FOR CONSTRUCTION SIGNS
ON TWO LANE OR MULTILANE UNDIVIDED LOW SPEED HIGHWAY**

Work Zone Note:

1. This Work Zone Sign Plan is intended for use on long-term stationary work zones/construction phases (3 days or more). All work zones or construction phases less than 3 days duration will use Traffic Control Plans shown in Section 645 of the Special Provisions.
2. All existing regulatory speed limit signs with posts within the work zone/project limits shall be removed and replaced with work zone speed limit sign assemblies (R2-1(25) and R2-5b(25) with "CONSTRUCTION AREA" and "\$250 FINE HRS 291C-104" Supplemental Signs).
3. Construction sign assemblies shall be installed on both the approaching and trailing ends of each work zone as shown on this plan.
4. Each construction warning sign shall have a minimum of two (2) Type II OM. Each work zone speed limit assembly shall have a minimum of one (1) Type II OM. Installation of each Type II OM shall be considered incidental to Item No. 621.7100, Construction Sign with Posts.
5. Upon the completion of all physical work or as directed by the Engineer, all construction signs and work zone speed limit assemblies shall be removed. All speed limit signs and posts that were existing at the start of the project within the work zone/project limits shall be restored back to their original locations and configurations.
6. Placement of construction signs shall not obstruct the path of pedestrians and bicyclists.
7. The removal and restoration of existing regulatory speed limit signs shall be considered incidental to Item No. 621.7100, Construction Sign with Posts.
8. The installation, maintenance and removal of work zone speed limit sign assemblies shall be paid for under Item No. 621.7100, Construction Sign with Posts.
9. The work zone speed limit signs shall be new and become the property of the Contractor.

ORIGINAL PLAN	SURVEY PLOTTED BY	DATE
NOTE BOOK	DRAWN BY	
DESIGNED BY	CHECKED BY	
DATE		
BY		
NO.		

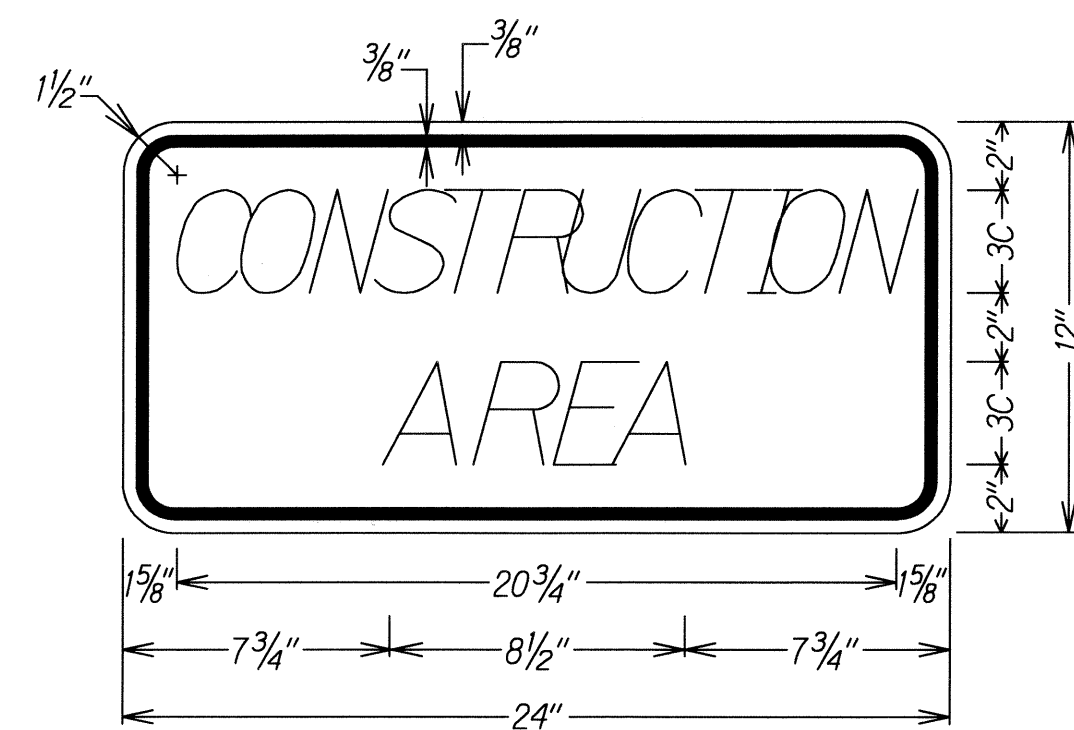

LEGEND: BLACK
BACKGROUND: ORANGE

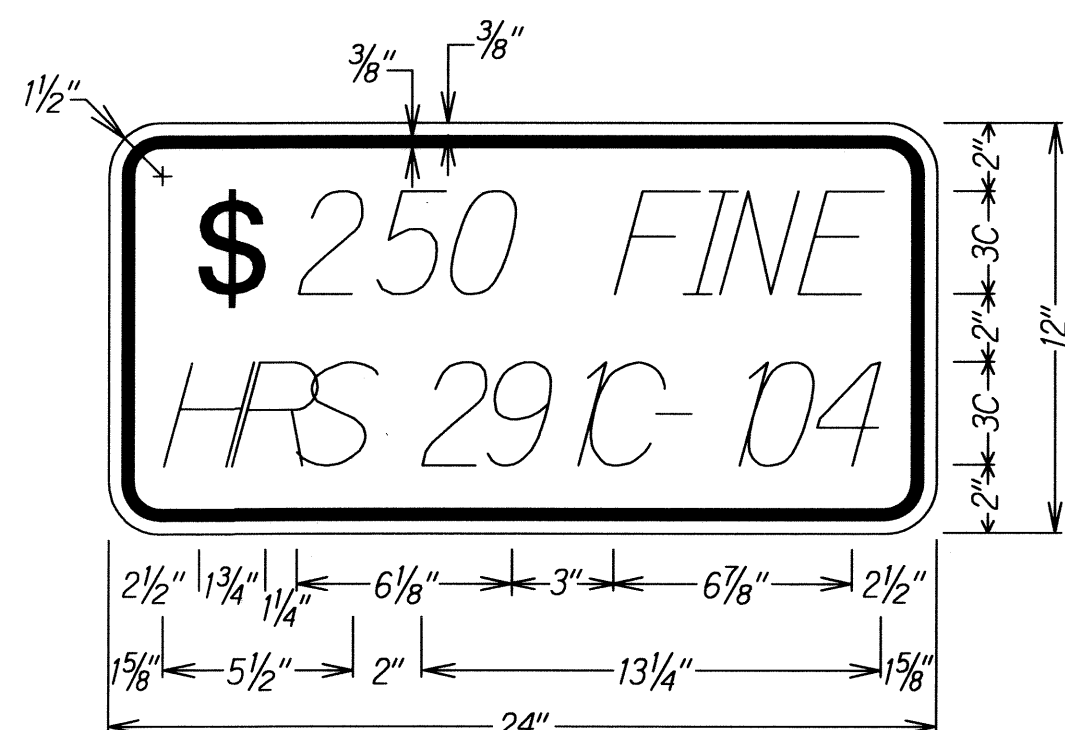

LEGEND: BLACK
BACKGROUND: WHITE

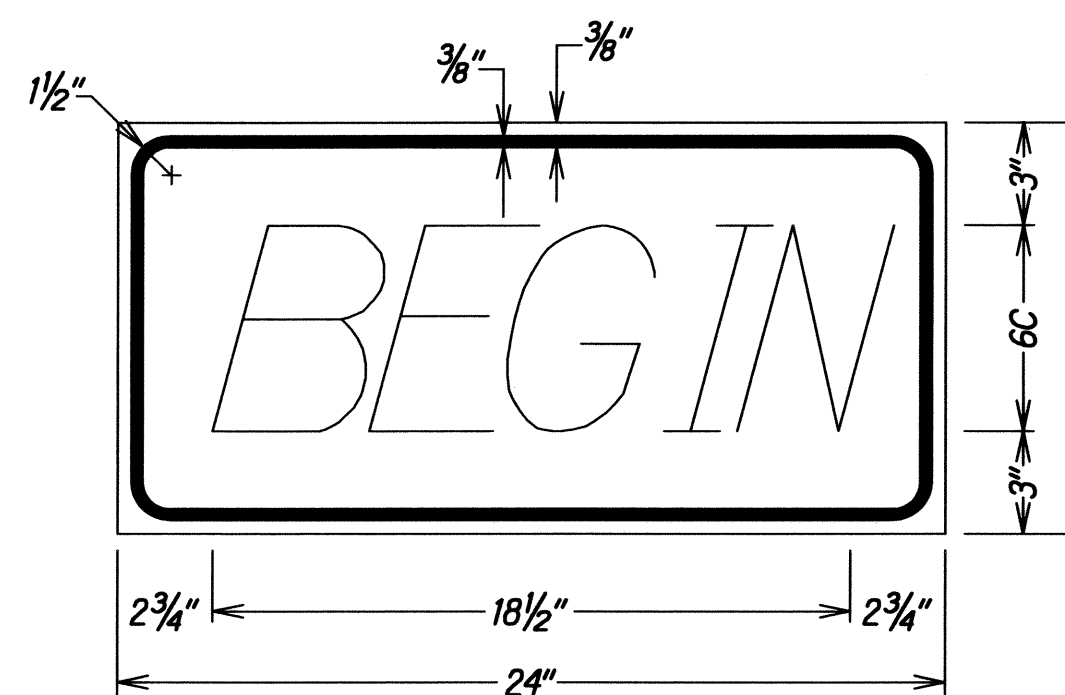

LEGEND: BLACK
BACKGROUND: ORANGE

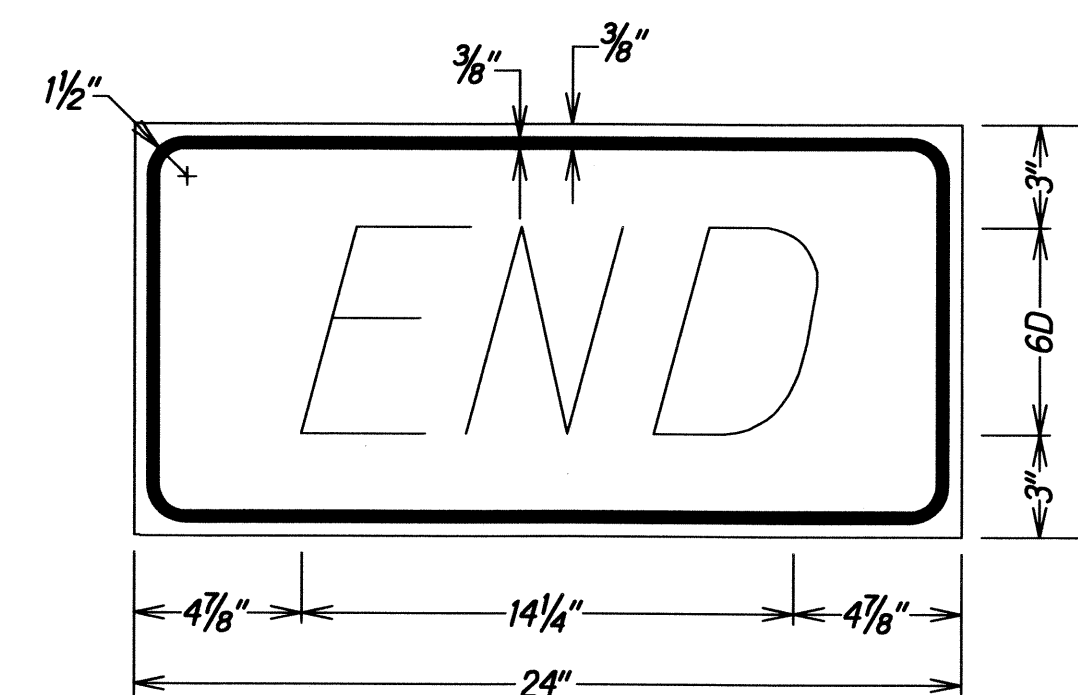

LEGEND: BLACK
BACKGROUND: ORANGE

STATE OF HAWAII
DEPARTMENT OF TRANSPORTATION
HIGHWAYS DIVISION

**LOW SPEED UNDIVIDED HIGHWAY
WORK ZONE SIGNING PLAN, NOTES & DETAILS**

MANELE ROAD REPAIR & MAINTENANCE
At Various Locations
Project No. 440B-01-11M
Date: June, 2011

Not To Scale

SHEET No. 1 OF 1 SHEETS