

TYPICAL DETAIL FOR WORK ZONE SIGNS
ON TWO LANE HIGH SPEED HIGHWAY

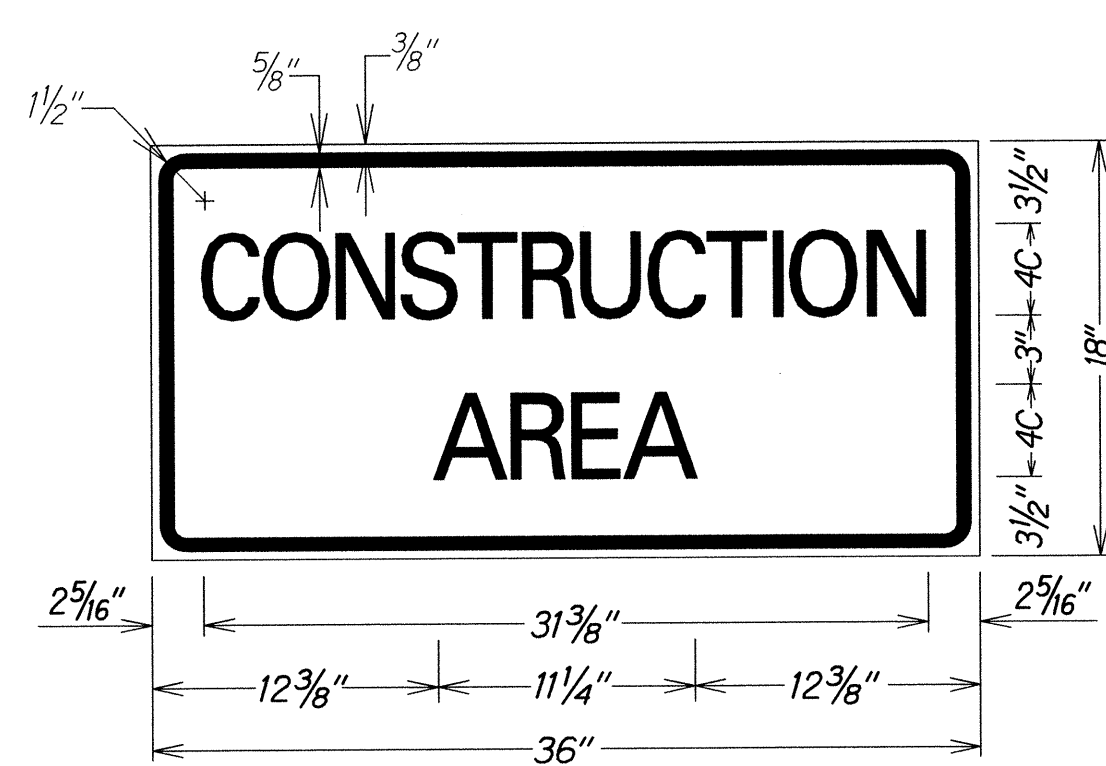

LEGEND: BLACK
BACKGROUND: ORANGE

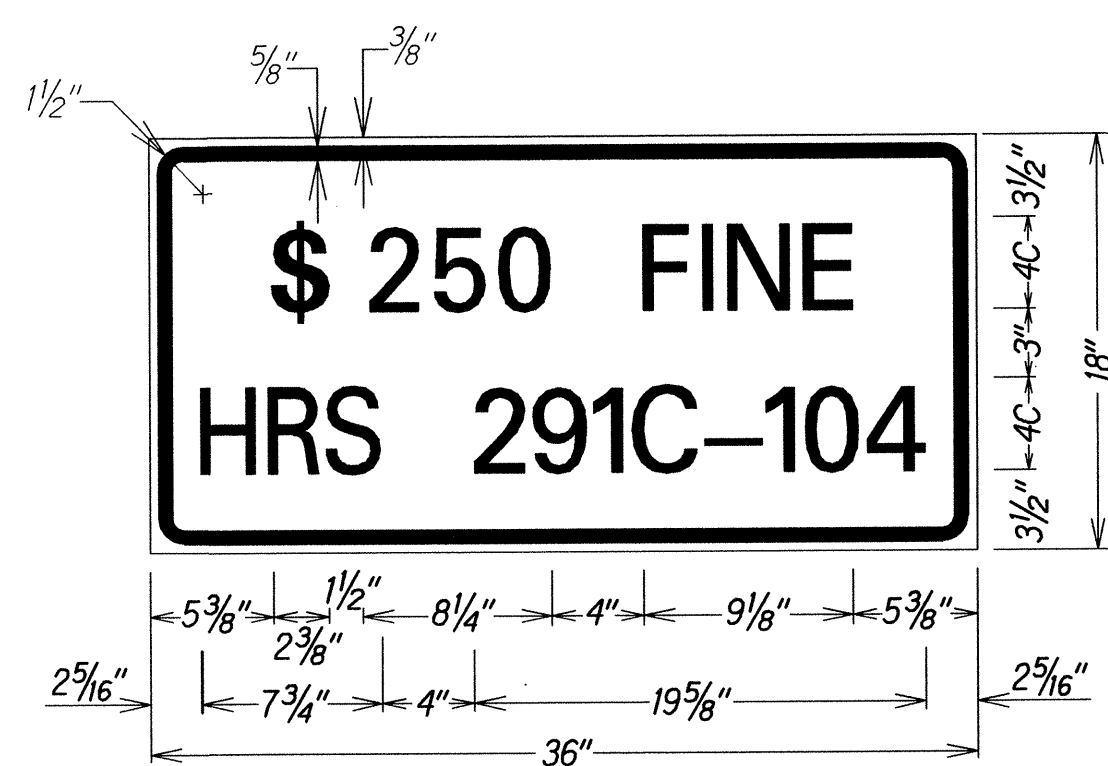

LEGEND: BLACK
BACKGROUND: WHITE

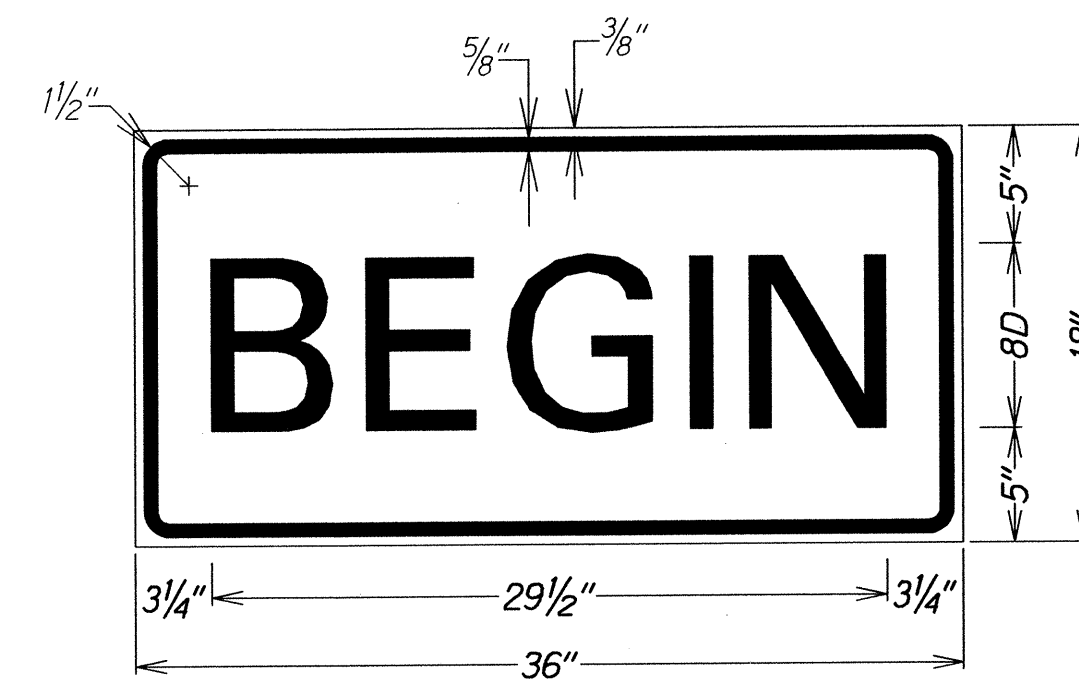

LEGEND: BLACK
BACKGROUND: ORANGE

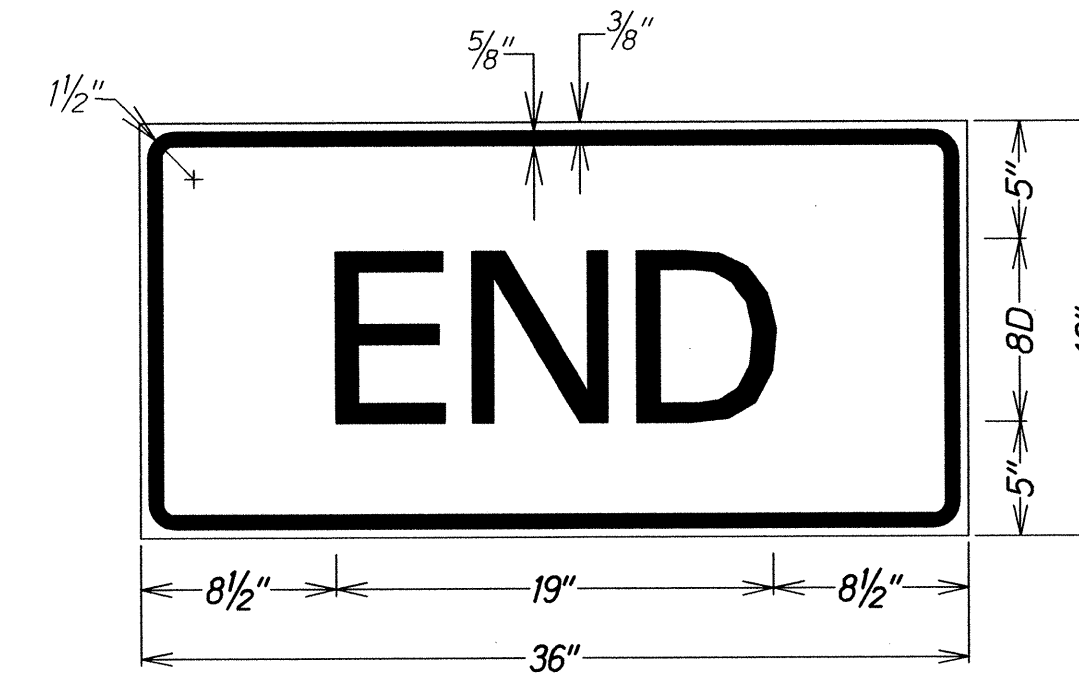

LEGEND: BLACK
BACKGROUND: ORANGE

Work Zone Notes:

1. This Work Zone Sign Plan is intended for use on long-term stationary work zones/construction phases (3 days or more). Contractor shall use Traffic Control Plans shown in Section 645 of the Special Provisions.
2. All existing regulatory speed limit signs within the work zone/project limits shall be temporarily replaced with applicable signs. Work zone speed limit sign assemblies and supplemental signs shall be temporarily installed within work zone/project limits.
3. Work Zone sign assemblies shall be installed on both the approaching and trailing ends of each work zone as shown on this plan.
4. Each construction warning sign and work zone speed limit assembly shall have a minimum of two (2) Type OM2-2V. Installation of each Type OM2-2V shall be considered incidental to Item No. 645.1000 - Traffic Control.
5. Upon the completion of all physical work or as directed by the Engineer, all construction signs and work zone speed limit assemblies shall be removed. All speed limit signs and posts that were existing at the start of the project within the work zone/project limits shall be replaced.
6. Placement of Work Zone signs shall not obstruct the path of pedestrians and bicyclists.
7. Maintenance and removal of work zone speed limit sign assemblies shall be considered incidental to Item No. 645.1000 - Traffic Control.

| | |
|-------------------|-------|
| DATE | |
| SURVEY PLOTTED BY | |
| DRAWN BY | |
| DESIGNED BY | |
| QUANTITIES BY | |
| CHECKED BY | |
| NOTE BOOK | |
| FILE NO. | |
| PROJECT NO. | |
| CHECKED BY | |

8/12/03 - /usr21/1/mw/sterle/consign/21n.dgn

STATE OF HAWAII
DEPARTMENT OF TRANSPORTATION
HIGHWAYS DIVISION
**HIGH SPEED UNDIVIDED HIGHWAYS
WORK ZONE SIGNING PLAN, NOTES&DETAILS**
MAMALAHOA HIGHWAY
PAVEMENT PREVENTIVE MAINTENANCE
Kapapala Ranch to Hawai'i Volcanoes National Park
Federal Aid Project No. STP-011-2(042)
Scale: None Date: February, 2013
SHEET No. 1 OF 1 SHEETS